



USAID
FROM THE AMERICAN PEOPLE

Maternal and Child
Survival Program



Manual of Standards for Family Planning Services

Revised, 2017



USAID
FROM THE AMERICAN PEOPLE

*M*aternal and Child
Survival Program



Manual of Standards for Family Planning Services

Revised, 2017

This publication was revised with support of the United States Agency for International Development (USAID), under flagship Maternal and Child Survival Program (MCSP), and does not necessarily reflect the views of USAID or the U.S. Government.

TABLE OF CONTENTS

ABBREVIATIONS AND ACRONYMS	xi
Acknowledgements	xiii
Message from the Chair, FP 2020 Sindh	xv
Foreword	xvii
Preface	xix
Chapter 1 	FAMILY PLANNING SERVICE DELIVERY
Country Profile	1
Pakistan's Population Welfare Programme: History	2
Fp2020 and Pakistan's Response	3
Provincial Context	4
Pakistan's National and Provincial Population Sector Initiatives	7
Population Policy of Sindh-2016	7
Costed Implementation Plan for Sindh	8
Quality of Care	11
List of Quality of Care Indicators	13
Checklists on QoC for Service Delivery Points	14
Emergency Medicine List	18
Chapter 2 	COUNSELLING AND INFORMED CHOICE IN FAMILY PLANNING
Introduction	19
Steps of Family Planning Communication	19
Principles of Good Counselling	20
Framework of Counselling	20
Balanced Counseling Plus Strategy	22
Algorithm for using Balanced Counseling Plus Strategy	23
Benefits of Counselling	24
Qualities of a Good Counsellor	25
Standards of a Good Counsellor	27
Instructions to the Counsellor	28
Informed Choice	28
Informed Consent	29
Client Assessment	29
Counselling of Clients with Special Needs	30
Counselling Men	35

Rumours and Misconceptions	36
Relationship between Contraceptive Methods and Sexual Life	37
The Rights of Family Planning Clients	37
Chapter 3 	
Healthy Timing and Spacing of Pregnancy	
Introduction	41
Key Research Findings about the Risks of Closely Spaced Pregnancies	42
Pakistan and Birth Spacing	43
Policy	43
Standards	43
Rationale	44
The Difference between “Birth Interval” and “Interpregnancy Interval”	44
Benefits of HTSP for Newborns and Infants	45
Benefits of HTSP for Mothers	45
Benefits of HTSP for Delaying Early Childbearing among Adolescents	45
Counselling Skills for HTSP	47
Chapter 4 	
ASEPSIS/INFECTION PREVENTION IN FAMILY PLANNING	
Introduction	49
Standard Precautions	49
Hand Hygiene	51
Gloves	53
Personal Protective Equipment and Drapes	54
Use of Antiseptic	56
Skin Preparation prior to Surgical Procedures	57
Instructions for Cervical or Vaginal Preparation	58
Skin Preparation for Injections	58
Safe Practices in Operating Rooms	58
Instruments Causing Injuries	59
Safe Handling of Hypodermic Needles and Syringes	60
Infection Prevention Techniques	62
Instrument Processing	62
Waste Management	70
Chapter 5 	
Medical Eligibility Criteria	
Introduction	75
Barriers to Contraceptive Use	75

Addressing Medical Barriers: World Health Organization Medical Eligibility Criteria	76
Identification of Conditions	76
WHO Medical Eligibility Criteria 2015 Updates	78
Chapter 6 NATURAL METHODS	
Introduction	119
Lactational Amenorrhoea Method (LAM) Family Planning Method Based on Breastfeeding	120
Counselling for Breastfeeding	126
Contraception for Non-Lactating Mothers	127
Suitable Methods of Contraception during Lactation	127
Fertility Awareness-Based Methods	127
Calendar-Based Methods	130
Symptoms-Based Methods	134
Withdrawal Method (Coitus Interruptus)	139
Chapter 7 BARRIER AND PROTECTIVE METHODS	
Introduction	143
Policy	143
Standards	143
Male Condoms	143
Female Condoms	147
Chapter 8 ORAL CONTRACEPTIVE PILLS	
Introduction	151
Policy	151
Standards	151
Combined Oral Contraceptive Pills	152
Progestin-Only Pills	162
Chapter 9 INJECTABLES	
Introduction	169
Policy	169
Standards	169
Progestin-Only Injectables	169
Combined Injectable Contraceptives	178

Chapter 10 	INTRAUTERINE CONTRACEPTIVE DEVICE (IUCD)	
Introduction		185
Policy		185
Standards		185
Copper-Bearing Intrauterine Contraceptive Devices		186
Hormone-Containing Intrauterine Contraceptive Devices		216
Giving Advice on Side Effects		220
Chapter11 	Implants	
Introduction		221
Types of Implants		221
Policy		222
Standards		222
Mode of Action		222
Effectiveness		222
Advantages		223
Limitations		223
Who can use the Implants		225
When to Start		226
Equipment and Supplies Needed for Implant Insertion		229
Technique for Insertion of Implanon-1 Rod		230
Technique for Insertion of SinoPlant / Jadelle Implants -2 Rods		231
Technique for Removal of Implants		236
Old Technology		238
Chapter 12 	VOLUNTARY SURGICAL CONTRACEPTION	
Introduction		239
Policy		239
Standards		240
Female Sterilization		240
Techniques of Female Sterilization		246
Vasectomy		253
Informed Consent		258
Follow-Up		258
Reversal of Tubal Ligation and Vasectomy		258
Recordkeeping		259
Standard Facilities for a Reproductive Health Service Centre		259
Staff Requirement		261

Other Material and Medicine Required for Minilaparotomy	262
Medical History Record Card for Tubal Ligation/Vasectomy	264
Chapter 13 	EMERGENCY CONTRACEPTIVES
Introduction	265
Policy	265
Standards	266
Mode of Action	266
Effectiveness	266
Advantages	266
Limitations	267
Method of Use	267
Method-Specific Counselling for Emergency Contraception	271
Chapter 14 	ADVANCES IN CONTRACEPTIVE TECHNOLOGY
Introduction	273
Policy	273
Standards	273
Barrier Methods	274
Female Barrier Method	274
Caya contoured diaphragm (formerly SILCS)	275
Hormonal Contraceptives	275
Progestogen-only vaginal rings- PVR	277
Injectable Contraceptives	277
Intrauterine Contraceptive Devices	283
Male Methods	284
Chapter 15 	Postpartum Family Planning
Introduction	287
Policy	287
Standards	288
Overview of Postpartum/Postnatal Family Planning	288
Family Planning Methods for Postpartum Women-Updates	289
Postpartum Intrauterine Contraceptive Device	290
Postpartum Implants	308
Integration of Postpartum Family Planning Services	311

Chapter 16 	RTIs/STIs, HIV/CLINICAL DISEASE 1,2 (MILD) 3,4 (SEVERE) AND HEPATITIS	
Introduction		313
Reproductive Tract Infections		313
Sexually Transmitted Infections		313
Policy		314
Standards		314
Classification of RTIs/STIs		314
Strategies for Control		316
Role of the Health Care Provider		316
Protocol for Treatment		316
HIV/Clinical disease 1,2 (Mild) 3,4 (Severe)		331
Stages of HIV Infection		331
Transmission of HIV/Clinical disease 1,2 (Mild) 3,4 (Severe)		332
Hepatitis		333
Contraceptives for Clients with STIS, HIV/AIDS		335
Chapter 17 	MALE AND FEMALE INFERTILITY	
Introduction		337
Role and Responsibilities of Family Planning Services		337
Definitions		337
Fertility		338
Initial Approach to an Infertile Couple at the Family Planning Clinic		340
Secondary Evaluation of an Infertile Couple		340
Goals of the Medical Evaluation of an Infertile Couple		341
Follow-Up		343
Treatment Options		344
Chapter 18 	CONTRACEPTIVE SECURITY	
Introduction		345
Definition		345
Elements of Contraceptive Security		345
Conclusion		347
Working out Monthly Contraceptive Requirement—Replenishment for RHS-A Centre/MSU/MWC/FHC		349
Couple Year of Protection (CYP)		350
PWD’s List of Contraceptive Logistic Record/Reports (CLRS)		350

Chapter 19 | TRAINING/HUMAN CAPACITY DEVELOPMENT

Training	351
Principles of learning in Training	351
Training Need Assessment	352
Guidelines for Planning Training	352
Trainer Selection Criteria	353
Levels of Trainers	353
Training Team Composition	353
Participant Selection	354
Training Curriculum Standardization	354
Training Session Preparation	354
Training Site Selection and Preparation	355
Logistics and Other arrangements	355
Steps in Implementing Training	356
Reviewing the day's activities	357
Reporting of the Training Activity	358
Training Certification	358
Annexure-A: Checklist for preparing a training event	360
Annexure-B: Training Reporting Format/Outline	361
Annexure-C: Checklist for Training Site Selection and Preparation	362

Chapter 20 | SUPPORTIVE SUPERVISION & MONITORING

Introduction	369
Supportive Supervision	369
Responsibilities of Supportive Supervisor	370
Who can do Supportive Supervision	371
Process of Supportive Supervision	371
Planning a Supportive Supervision Visit	373
Conducting a Supportive Supervision Visit	375
Monitoring	376
Supportive Supervision Checklist	378
Action Planning Format	398
Questions for a Family Planning Services Exit Interview	399
Severe Adverse Event Report Form	400
Performa for Death Investigation	403
References	405

ABBREVIATIONS AND ACRONYMS

ART	Antiretroviral therapy
ARV	Antiretroviral
BBT	Basal body temperature
BHU	Basic Health Unit
BTL	Bilateral tubal ligation
CBO	Community-based organization
CIC	Combined injectable contraceptive
COC	Combined oral contraceptive
CPR	Contraceptive prevalence rate
CRC	Client clinical record card
CS	Contraceptive surgery
DOH	Department of Health
DTC	District Technical Committee
DVT	Deep venous thrombosis
EC	Emergency contraception
ECP	Emergency contraceptive pill
ENG	Etonorgestrel
EPI	Expanded Programme on Immunization
FP	Family planning
FPAP	Family Planning Association of Pakistan
FTO	Field Technical Officer
FWA	Family Welfare Assistant
FWC	Family Welfare Centre
FWW	Family Welfare Worker
HBV	Hepatitis B virus
HCV	Hepatitis C virus
HLD	High-level disinfection
HRD	Human resource development
HTSP	Healthy Timing and Spacing of Pregnancy
ICPD	International Conference on Population and Development
IEC	Information, education and communication
IPC	Interpersonal communication
IRC	Institutional Reimbursement Cost
ISO	International Standards Organization
IUCD	Intrauterine contraceptive device
LAM	Lactational amenorrhoea method
LHW	Lady Health Worker
LMP	Last menstrual period
MCH	Maternal and child health
M&E	Monitoring and Evaluation
MEC	Medical Eligibility Criteria
MIS	Management information system

MO	Medical Officer
MSU	Mobile Service Unit
MSV	Medical site visit
NFP	Natural family planning
NGO	Nongovernmental organization
NGO CC	Nongovernmental Organization Coordinating Council
NIPS	National Institute of Population Studies
NSAID	Nonsteroidal anti-inflammatory drug
NSV	No-scalpel vasectomy
OCP	Oral contraceptive pill
OPD	Outpatient department
PCOS	Polycystic ovarian syndrome
PE	Pulmonary embolism
PET	polyethylene
PID	Pelvic inflammatory disease
PLD	Provincial Line Department
PMTCT	Prevention of mother-to-child transmission (of HIV)
PoA	Plan of Action
POP	Progestin-only pill
PGR	Population growth rate
PPE	Personal protective equipment
PPFP	Postpartum family planning
PWDS	Population Welfare Department, Sindh
QoC	Quality of care
RH	Reproductive health
RHS	Reproductive Health Services
RHSC	Reproductive Health Services Centre
RMP	Registered medical practitioner
RTI	Reproductive tract infection
SDG	Sustainable Development Goal
SDM	Standard Days Method®
SIGN	Safe Injection Global Network (WHO)
SMC	Social marketing of contraceptives
SSRI	Selective serotonin reuptake inhibitor
STI	Sexually transmitted infection
TL	Tubal ligation
TOT	Training of trainers
VSC	Voluntary surgical contraception
WHO	World Health Organization

ACKNOWLEDGEMENT

The finalization of this manual was not an easy task. However, knowledge is changing so quickly that updates to the content and the addition of newer concepts were needed based on Medical Eligibility Criteria 2015.

In the post devolution scenario, the Population Welfare Department, Sindh adopted the Manual. Later on, it was an integrated into the Costed Implementation Plan (CIP), Sindh under its Strategic Areas 2. An initial revision was also conducted by Dr. Azmat Waseem, Director, Medical, PWD, Sindh. Later on, Jhpiego-an affiliate of Johns Hopkins University under Maternal Child Survival Project (MCSP) Project, called a consultative meeting. Maternal and Child Survival(MCSP) Project is a family planning project supported by the United States Agency for International Development (USAID) to accelerate Family Planning in Pakistan . The officials of Departments of Health and Population from Sindh and other provinces; experts and professionals contributed in the revision of the document.

The Department of Population Welfare, Sindh is thankful to all professionals and experts who contributed during the entire process. Especial thanks to USAID for their contribution and assistance under MCSP. We are thankful for the continuous support and insight of Dr. Farid Midhet, Country Director Jhpiego Pakistan. We are also thankful to Dr. Ricky Lu, Director FP/RH, Jhpiego for his persistent guidance and technical insight during the revision. The efforts of Dr. Zonobia Zafar, Senior Technical and Program Advisor, MCSP are also acknowledged who worked tirelessly and coordinated all of these efforts to give the final shape to the document. Dr. Fauzia Assad, Chief of Party, MCSP besides, providing her technical inputs also coordinated the team. Her efforts are highly appreciated.

Dr. Azmat Waseem, Director, Medical, Population Welfare Department, Sindh continuously worked with the team of reviewers and provided her best inputs based on her vast experience in the public sector.

Dr. Talib Lashari, Technical Advisor, CIP and Focal Person, FP2020 Sindh has been instrumental in integrating all the efforts; providing his technical inputs and expediting the process of finalizing.

We greatly appreciate the efforts of the following participants for their kind consultation

- Dr. Yasmeen Sabeeh Qazi, Senior Country Advisor, David & Lucile Packard Foundation
- Dr. Samina Asif, In-charge RHS A, Abbasi Shaheed Hospital, Karachi
- Dr. Farzana Bhagat, In-charge RHS A, Police Hospital, Karachi
- Dr. Talat Abro, Deputy Director (RHS), PWDS
- Prof. Dr. Sadiya Ahsan Pal, Obst/Gynaecologist, Vice-President, Society of Obs/Gynae Pakistan (SOGP)
- Dr. Mumtaz Esker, Senior Advisor, Marie Stopes Society
- Syed Ilyas Haider, Director from Central Warehouse and Supplies, MNHS,

- Dr. Laila Shah, Director, Sukh, Jhpiego;
- Dr. Aleya Ali, NCMNH;
- Dr. Sana Durvesh, Greenstar,
- Dr. Marium Waqas, Health Policy Plus,
- Ms. Renuka Swami, National IM officer, UNFPA and
- Dr. Sara, World Health Organization

We are extremely thankful to representatives from Department of Health namely; Dr. Sahib Jan Badar, Provincial Coordinator-MNCH, Sindh, Dr. Farhana Memon, Epidemiologist-MNCH, Sindh and Ms. Syfoor Bibi, Technical Lead for MNCH, Sindh.

The Manual has been printed by the CIP/PIU for its wider circulation, orientation of managers, providers and wide ranging training program across the province.

CIP/Plan Implementation Unit
Population Welfare Department, Sindh

FOREWORD



Family planning (FP) is a key development issue that impacts the quality of lives of families, communities, and broader society. Increased use of FP services leads to large improvements in the health of mothers and children, the status of women, and economic development. Government of Balochistan Health Department is making continuous efforts to integrate Family Planning into MNCH services. For successful implementation of Family Planning Program, it is essential to overcome myths and misconceptions about modern FP methods and have open discussion and dialogue in the community about the role of FP in safeguarding the health and well being of our mothers and children.

Therefore, a comprehensive and updated document with technical guidelines on this subject was the need of time with changing strategies and approaches. The resulting document, Manual of Standards for Family Planning Services will be a reference document for all the managers and providers. It will ensure everyone is working in concert, and that we are all using our limited resources to their greatest effect. This exercise would not have been possible without technical and financial support from USAID through Jhpiego under Maternal and Child Survival Program (MCSP). The DOH would like to thank all individuals and institutions for their contributions to this document, and urges all public and private institutions to make maximum use of it to guide FP implementations in the province.

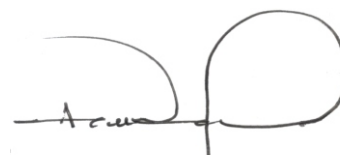

Mr. Asmat Ullah Kakar
Secretary, Government of Balochistan
Health Department

PREFACE



I am glad to use this opportunity for expressing my pleasure that fifth edition of the Manual of Standards for Family Planning Services has been published. I do appreciate tireless efforts of the Maternal and Child Survival (MCSP) Project for helping this edition developed. I owe my gratitude to the support of United States Agency for International Development (USAID) and Jhpiego — an affiliate of Johns Hopkins University, for their support in implementing the project.

Department of Population Welfare, Balochistan has maintained its standards of organizational efficiency at national level. The department has devised its population policy in view of future roles and responsibilities in population planning, besides, addressing reproductive health issues in local socio-cultural and geographical context of the province.

The department is committed in achieving universal access to reproductive health and raising the contraceptive prevalence rate to 25% by 2020. Therefore, it promotes family planning practices for the successful implementation of the population welfare program in a holistic manner for the betterment of people, particularly women and children. As per SDGs, FP-2020 and CIP commitments, the department is striving towards the goal of providing quality reproductive health especially family planning services.

I feel confident that this manual will prove to be useful for the trainers and service providers working in the public, private, and NGO working in family planning sector. The manual serves as SOP for them at minimum defined standards for family planning and reproductive health service provision.

I acknowledge the honest support of Jhpiego, an affiliate of Johns Hopkins University, with great debt of gratitude for providing technical support in updating the manual. I would also extend my sincere thanks to the officers of the Technical Wing of my organization and others for their support and professional contributions in making this manual published.



Noor-ul-Haq Baloch
Secretary
Population Welfare Department,
Government of Balochistan

1

FAMILY PLANNING SERVICE DELIVERY

Country Profile

Pakistan is the sixth most populous country in the world, with an estimated population growth rate of around 1.9 percent per annum in 2016, representing an annual addition of almost three million people. The country is facing great challenges to attain socio-economic development and break the vicious cycle of poverty. This annual addition to the population, in the context of low socio-economic indicators, not only dilutes the results of development efforts but also creates overwhelming demand on limited resources. According to the Population Reference Bureau, Pakistan's population in 2015 was 199 million, and it ranked 6th in the world and 4th in the region, after Indonesia. The 2050 projections are alarming; with Pakistan's population projected at 344 million. Based on these growth patterns and trends, the economy will be unable to sustain the growing population with hardly any scope for improvement in the quality of life, even under the most favourable circumstances. This situation is, therefore, a matter of deep concern and becomes a central issue in the overall planning perspective as well as the strategy for alleviating poverty in the country.

Figure 1-1. Distribution of Men and Women of Reproductive Age in Pakistan

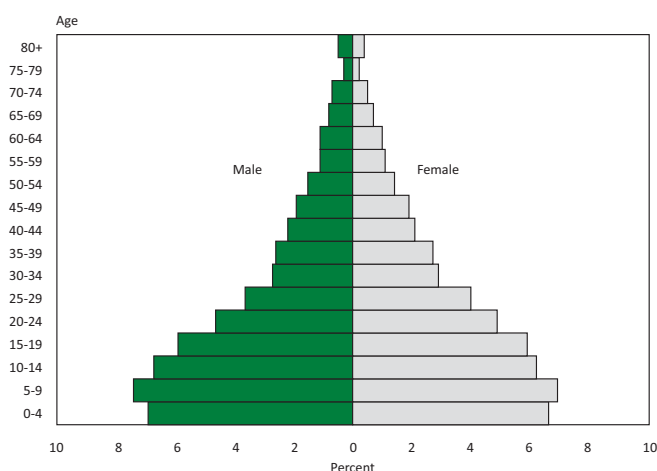

Source: National Institute of Population Studies (NIPS) [Pakistan].. Pakistan Demographic and Health Survey 2012 - 2013. National Institute of Population Studies and Macro International Inc.: Islamabad, Pakistan.

Pakistan's Population Welfare Programme: History

Family planning (FP) activities were introduced in Pakistan's First Five Year Plan (1955–60) through the Family Planning Association of Pakistan (FPAP) and other voluntary organizations. In the second Five Year Plan (1960–65), FP services were extended through the health infrastructure; however, in the third Five Year Plan (1965–70), an independent Family Planning set-up was created, mass- scale information, education, and communication (IEC) activities were launched, and a service delivery network was established. In the next plan (1970–75), the “Continuous Motivation Approach” was introduced by employing male-female teams of workers at the Union Council level. During 1975–80, the programme operated at a low key due to re-organization, political unrest, and suspension of IEC activities.

In 1981, an administrative re-organization was undertaken and a broad-based, multi-sectoral, and multi-dimensional strategy was conceived, developed, and introduced. In the sixth Plan period (1983–88), field activities were provincialized through a 1983 ordinance, the role of nongovernmental organizations (NGOs) was institutionalized through the NGO Coordination Council (NGO CC), social marketing of contraceptives (SMC) was introduced, and the National Institute of Population Studies (NIPS) was established. The strategies of the sixth Plan were pursued in the seventh Five Year Plan (1988–93), with emphasis on lowering the fertility level and a focus on a motivational campaign and widening the range of contraceptive methods for voluntary choice. Also, a special IEC programme and quality FP service delivery facilities were developed for the country's large cities, with a view to set trends for rural areas. The role of the District Office was expanded, and Divisional and Tehsil tiers were created. In fact, a breakthrough in the programme occurred during the later part (1990–93) of the seventh Plan.

In the eight Plan (1993–98), the population programme continued to receive strong political support from the highest levels, but because the plan was finalized before the International Conference on Population and Development (ICPD) held in 1994, the reproductive health (RH) framework was not fully reflected in it. However, an institutional mechanism to oversee, guide, and strengthen collaborative efforts to advance the FP/RH agenda was established by the creation of a Coordination Committee of Health and Population Welfare Department. Later, in the ninth Five Year Plan (1998–2003), the programme was realized with a post-ICPD Plan of Action (PoA), while keeping in view the local socio-cultural conditions and priorities.

In March 2000, the Government initiated restructuring and right-sizing of the public sector; an assessment of the Population Welfare Programme was also undertaken, wherein it was noted that the programme was moving in the right direction and the fertility transition had set in and had to be sustained. The process led to formulation of the Population Policy in 2002, setting the long- term vision for the population sector. By end of the ninth Plan and later, the programme has been able to raise the contraceptive prevalence rate (CPR) and reduce the population growth rate (PGR), thereby heading towards achievement of population stabilization.

In 2010, devolution of power to provinces through 18th amendment in the constitution resulted in dissolution of Ministry of Population Welfare and transfer of the subject to the provinces. Thus, the Population Welfare Departments in provinces took a lead role in population policy, plans, programs and projects and their implementation.

The provincial Population sectors introduced following programmatic interventions in line with the stated strategies:

- Launch a well-conceived IEC campaign to address macro-population issues and socio-cultural constraints.
- Introduce a cadre of Male Mobilizers at Union Council level for enhancing male involvement in FP/RH.
- Conduct human resource development (HRD) activities for programme managers to promote result-oriented management through the Management Information System (MIS).
- Facilitate and oversee FP service delivery in health outlets and Provincial Line Departments and compare against agreed-upon performance indicators.
- Increase the existing level of SMC and engage private sector industrial organizations to undertake FP, advocacy, and service delivery programmes.
- Involve NGOs/civil society organizations through the National Trust for Population Welfare (NATPOW) and strengthen public-private partnership.
- Decentralize operational activities at district level and below for efficiency of fiscal, administrative, and programme transfers.
- Enhance involvement of trained private sector service providers in rural and slum areas.

FP2020 and Pakistan's Response

On July 11, 2012, at London Summit on Family Planning, Pakistan committed to work towards achieving universal access to reproductive health services and improve contraceptive prevalence rate to 55% by 2020. The commitment was taken forward with all four provinces to involve public and private healthcare facilities in improving the CPR. Table 2 provides a snapshot of national and provincial commitments for 2020 and their status in 2012/13. The province of Sindh has developed their Costed Implementation Plans (CIP) to provide guidance for implementation of a family planning program with defined targets and a roadmap to deliver the outcomes to advance towards FP2020 goals as per commitment made by Pakistan.

Table 2: Current Status on FP2020 Commitments				
	Current Status - 2012-13			FP2020 Commitments
	CPR (%)	Unmet Need (%)	Total Demand (%)	CPR (%)
Pakistan	35	20	55.5	55
Sindh	29.5	20.8	50.3	45
Punjab	40.7	17.7	58.3	52
KPK	28.1	25.5	53.6	42
Baluchistan	19.5	31.2	50.6	35

Source: NIPS; Pakistan Demographic and Health Survey 2012-13, Islamabad

Provincial Context:

Punjab

Punjab is the largest province with estimated population of 101 million in 2015. The present growth rate indicates alarming situation in future when population will be doubled after 36 years. In 2015, there were approximately 26 million women of reproductive age and estimated to reach 30 million by 2020. The CPR has increased considerably and the unmet needs and total fertility rate (TFR) has shown a declining trend.

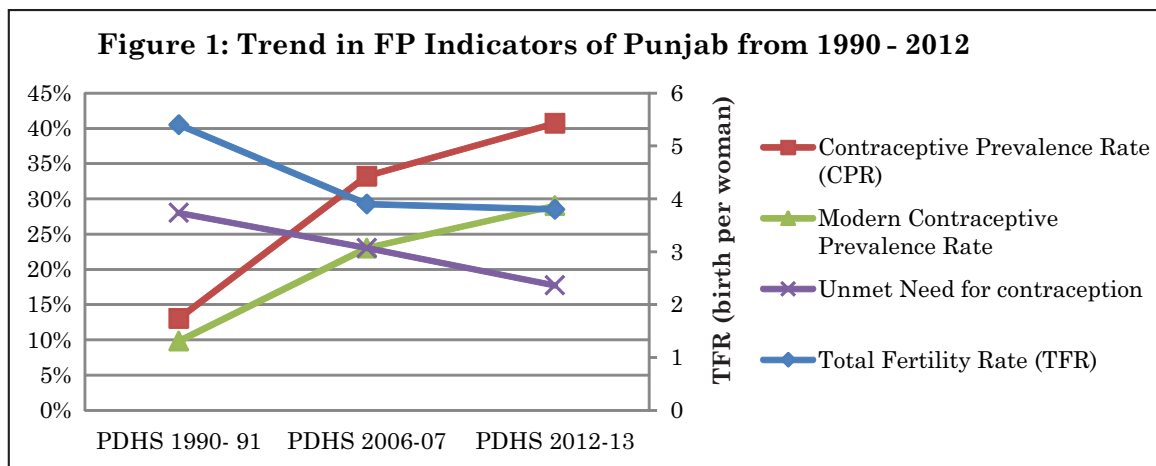

Sindh

In 2015, the estimated population of Sindh was approximately 42.4 million. With current fertility rate of 3.9 births and continuous migration from within the country and outside, the population is expected to reach 50 million by 2020. The CPR has increased as compared to PDHS 1990-91 data but has not improved much compared to PDHS 2006-07. Similarly the unmet need did not show any significant improvement compared to PDHS 1990-91.

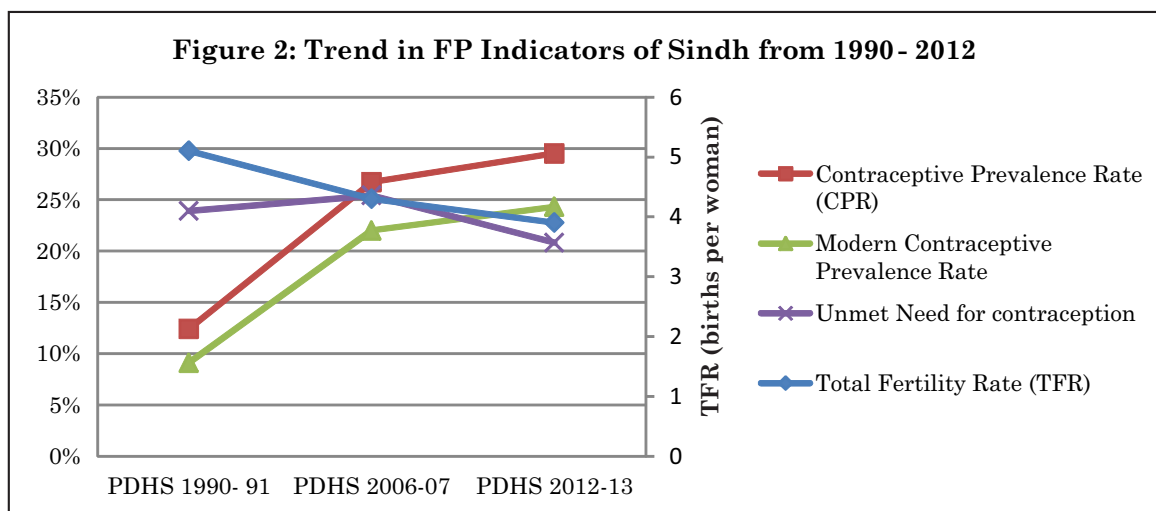

Baluchistan

The population of Baluchistan was approximately one million in 1951, which has increased to 8.5 million in 2015. It is estimated that within next 30 years the population will double. Though CPR has increased as compared to PDHS 1990 but the proportion of women with unmet needs has swollen. This can be attributed to increasing awareness about FP services. However, extensive efforts are warranted to address the unmet needs of 33% of women in Baluchistan.

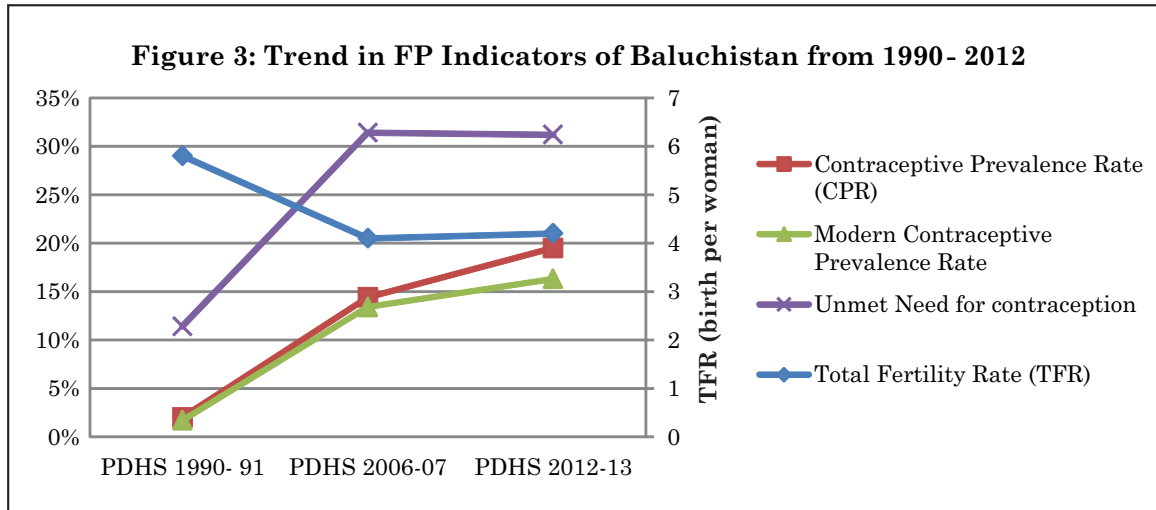

Khyber Pakhtunkhwa

In 1951 census, the population of Khyber Pakhtunkhwa (KPK), then NWFP, was approximately 4.5 million that reached to approximately 28 million in 2015. The fertility rate has decreased significantly from 5.5 births in 1990 to 3.9 in 2012. A drastic increase in the use of contraceptive services was observed starting from 8.6% in 1990 to 28% in 2012. However, not much difference was observed in the proportion of women with unmet need of FP.

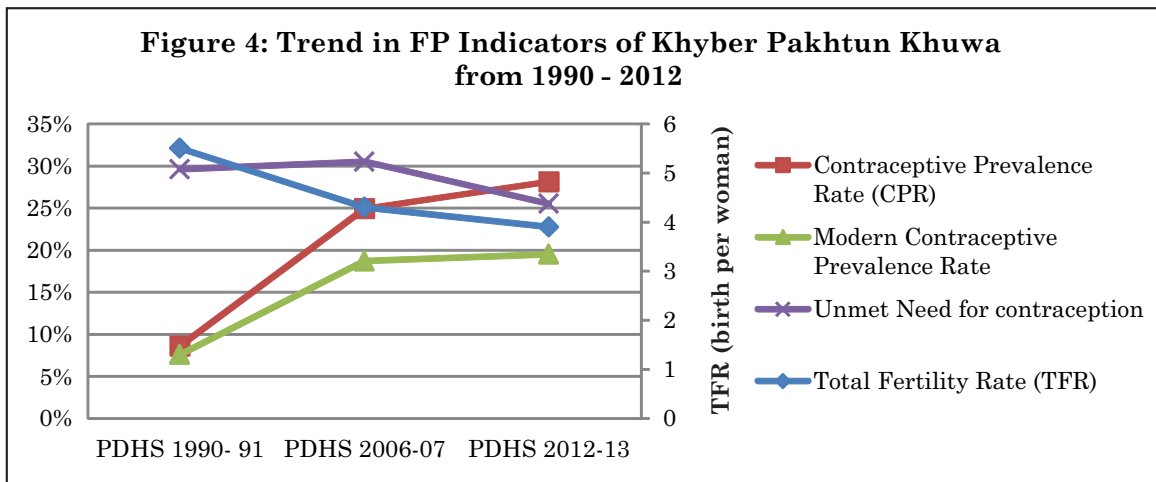

The Sustainable Development Goals

The United Nations General Assembly Open Work Group, on 19th July 2014, proposed Sustainable Development Goals (SDGs) as successor to the Millennium Development Goals. The proposal consisted of 17 goals with 169 targets including ending poverty and hunger, improving health and education, making cities more sustainable, combating climate change, and protecting oceans and forests. Listed below is the SDG-3 and its targets.

Goal 3. Ensure healthy lives and promote well-being for all at all ages

1. By 2030, reduce the global maternal mortality ratio to less than 70 per 100,000 live births.
2. By 2030, end preventable deaths of newborns and children under 5 years of age, with all countries aiming to reduce neonatal mortality to at least as low as 12 per 1,000 live births and under-5 mortality to at least as low as 25 per 1,000 live births.
3. By 2030, end the epidemics of AIDS, tuberculosis, malaria and neglected tropical diseases and combat hepatitis, water-borne diseases and other communicable diseases.
4. By 2030, reduce by one third premature mortality from non-communicable diseases through prevention and treatment and promote mental health and well-being.
5. Strengthen the prevention and treatment of substance abuse, including narcotic drug abuse and harmful use of alcohol.
6. By 2030, halve the number of global deaths and injuries from road traffic accidents.
7. By 2030, ensure universal access to sexual and reproductive health-care services, including for family planning, information and education, and the integration of reproductive health into national strategies and programmes.
8. Achieve universal health coverage, including financial risk protection, access to quality essential health-care services and access to safe, effective, quality and affordable essential medicines and vaccines for all.
9. By 2030, substantially reduce the number of deaths and illnesses from hazardous chemicals and air, water and soil pollution and contamination.
 - a. Strengthen the implementation of the World Health Organization Framework Convention on Tobacco Control in all countries, as appropriate.
 - b. Support the research and development of vaccines and medicines for the communicable and non-communicable diseases that primarily affect developing countries, provide access to affordable essential medicines and vaccines, in accordance with the Doha Declaration on the TRIPS Agreement and Public Health, which affirms the right of developing countries to use to the full the provisions in the Agreement on Trade-Related Aspects of Intellectual Property Rights regarding flexibilities to protect public health, and, in particular, provide access to medicines for all.
 - c. Substantially increase health financing and the recruitment, development, training and retention of the health workforce in developing countries,

especially in least developed countries and small island developing States.

- d. Strengthen the capacity of all countries, in particular developing countries, for early warning, risk reduction and management of national and global health risks.

Pakistan's National and Provincial Population Sector Initiatives

- National Population Commission, 2006
- Provincial Population Councils, 2006
- Joint Steering Committee of Health and Population, 2005
- Cabinet Committee for Social Sector Coordination (CCSSC)
- Focal points in all relevant Ministries/Divisions
- Revitalization of District Technical Committees
- Expansion of service delivery outlets
- Capacity building of training and research institutes
- Partnership with private and corporate sector organizations
- International Standards Organization (ISO) certification of service delivery outlets
- International Ulema Conference, 2005
- Follow-up of IDPD, 2006
- International Population Summit, 2005
- Follow-up of Population Summit, 2006
- Advocacy seminar for parliamentarians, 2005, and step-down activities to bring advocacy to lower levels of government
- International best practices for scaling up FP/RH
- Donor collaboration
- Friends of Family Welfare Centres
- National Commission for Human Development
- National Voluntary Movement
- Pakistan Postal Services
- Mass-media campaign for advocacy and behaviour change communication
- Youth/male involvement through interpersonal communication
- Adolescent and men's advisory centres
- Population issues included in curricula of 9th to 12th classes

Service Delivery outlets in Balochistan province under Population and Health Departments

(Source: Source: DHIS (District Health Information System) Cell Health Directorate Balochistan, PPHI, MNCH and National Program and Human Resource Development Balochistan)

Nature of Facility	Description	Department	Number of Facilities	No. of Human Resources	Population Covered
Static Units					
RHS-A	Hospital based units for provision of full range of reproductive health services comprising FP methods including CS (male, female); MCH care; prevention and management of reproductive tract infections and sexually transmitted infections including HIV/AIDS; management of reproductive health issues of adolescent boys and girls, men and women; infertility; early detection of breast and cervical cancers by promoting self-examination.	PWD	11 (02 Master Training Centers)	10	-
Family Welfare Centre (FWC)	FP information, counselling, follow-up for all methods except for implants CS; availability of contraceptives, medicines; MCH services, infant care including nutrition, growth monitoring, and common illnesses; referral of cases of infertility, HIV/AIDS; CS/implants.	PWD	170	5	5,000 – 7,000
No-Scalpel Vasectomy (NSV)	The five no-scalpel vasectomy (NSV) centres are situated at Karachi, Hyderabad, Larkana, Nawabshah and Moro. NSV is preferred method for male CS and is more simple and safe.	PWD	0		
Basic health units	A first-level care facility (FLCF) at Union Council level with preventive and basic curative services, referral, and basic FP services.	PPHI / DOH	635	MOs 232 (lady doctors 42 DOH & 39 PPHI contract), Pharmacists 2, Social Organizers 54, LHVs 326 of DoH & 156 PPHI contract, Medical Technicians (Male 478,	3,733,794

Nature of Facility	Description	Department	Number of Facilities	No. of Human Resources	Population Covered
				Female 190 DOH & 32 PPHI Contract), Dispensers 379, Vaccinators 401, Lab and X-ray Assistants 87	
Rural health centres	A First-Level Care Facility with curative services, basic surgeries, referral and FP basic services	DOH (recently outsourced)	125 (2-PPHI)		Cluster of Union Councils (50,000)
Tehsil Headquarters Hospitals (THQ)	A secondary-level care facility at the tehsil level with curative and minor surgery facilities with basic FP methods.	DOH (some of those outsourced)	10		2,000,000
District Headquarters Hospital (DHQ)	A secondary-level care facility with specialties of medicine, surgery, Gynaecology, Paediatric facilities, and basic FP methods. (EmONC) services in some districts.	DOH (some of those outsourced)	26		Covers the whole district population and in some cases referral from other districts as well.
50 Bed Hospitals	A secondary-level care facility with specialties of medicine, surgery, Gynaecology, Paediatric facilities, and routine FP services.	DOH	5	MOs-939, LMOs-303, LHVs-71, MTs- 41, FMTs-26, Dispensers- 69, Nurses- 798	Covers the whole provincial capital population including referral from periphery of whole Balochistan
Tertiary care and Specialized care Hospitals	Specialties in areas of medicine, surgery; FP methods, Specialized hospitals are dedicated to a certain specialty	DOH	5		
Outreach Facilities					
Mobile service units (MSU)	MSUs provide FP and reproductive health services to remote areas where other facilities are not available. The MSU operate from specially designed vehicles, which possess all the facilities of a mini-clinic. MSU ensures complete privacy for gynaecological procedures. Each MSU requires the organization of 10–12 outreach camps every month. Due to resource constraints MSUs are not fully functional.	PWD	55	03	12,000

Nature of Facility	Description	Department	Number of Facilities	No. of Human Resources	Population Covered
Social male mobilizers	Social Male Mobilizers are union council based workers. They are supposed to establish their office in their home. Two male mobilizers are to be recruited at each FWC. The mandate of Male Mobilizers is to increase acceptance of FP among the male population and use of male contraception methods. Male Mobilizers dispense condoms and pills. Most of the mobilizers are non-functional. In the wake of FP2020 goals, their role needs to be revisited.	PWD	Housed in each Union Council	101	1,000
Lady health workers (LHWs) and lady health supervisors	LHWs are women from within the community who are educated up to middle class and are trained in delivering FP and maternal, neonatal and child health (MNCH) services; promotion of health education, nutrition promotion and basic sanitation etc. They promote FP methods like condoms, pills, emergency contraceptive pills, and provide second injectable to married women of reproductive age.	DOH/ National Programme on FP and primary health care	FLCF-225	LHWs- 6720, LHS- 248 (At least 20 to 25 LHWs are supervised by each LHS)	39% of the total population of Balochistan province
Lady Health Visitors (LHVs)	Services of LHVs are placed at DHQ, RHCs, BHUs and MCH centres to provide FP and normal delivery services	DOH		BHU-326	746,759
Community Midwives (CMWs)	CMWs provide skilled maternity care services at the community level. Their skills in FP need to be improved.	DOH/MNCH Programme	-	194	970,000
Training Institutes					
Regional Training Institute	Specialized training centres in family planning and reproductive health package	PWD	1	37	-
Provincial Health Development Centre (PHDC) and District Health Development Centre (DHDCs) (select districts)	Trainings centres of DOH to provide trainings to DOH doctors, LHVs and other health care providers on health sector and FP.	DOH	PHDC-1 DHDC-5	PHDC- 1 (13 Technical and 16 Non-technical) DHDC-5 total 35 in Balochistan (2 Technical and 5 non-technical in each)	-

Quality of Care

Quality of Care (QoC) is a client-centred approach to provide high-quality health care as a basic human right; it is considered a critical element of FP/RH services.

It has been promoted by all stakeholders in the public and private sectors as well as by NGOs, as affirmed at international conferences. High-quality services ensure that clients receive the care that they deserve. Furthermore, providing better services at reasonable prices attracts more clients, increases the use of FP methods, and reduces the number of unintended pregnancies.

Improving QoC for clients means understanding their cultural values, previous experiences, and perceptions of the role of the health system, and then bringing RH service providers and the community together to map out a shared vision of quality. Similarly, enhancing the QoC given by health care providers requires identifying their motivations, addressing their needs (including general administrative and logistical support), and helping them to better understand and address clients' concepts of quality (Annex II). Creating a shared vision for improved QoC requires that programme managers, service providers, researchers, and consumers advocate the idea that quality matters. Given time and effort, the ongoing attempt to improve the QoC will translate into services that meet minimum quality standards and satisfy the needs of clients and providers to bridge the gap of unmet need.

Elements of Quality

Choice of FP method refers both to the number of methods offered on a reliable basis and to their intrinsic variability. The methods offered serve significant subgroups as defined by age, sex, contraceptive intention, lactation status, and health profile.

Information given to client refers to the information imparted during service contact that enables clients to freely choose and use contraception with satisfaction.

Technical competence involves factors such as the skill of the health care provider, observance of protocols, and meticulous asepsis required for dispensation of clinical methods.

Inter-personal relations are the personal dimensions of service provision.

Mechanisms to encourage continuity indicate a programme's interest and ability to promote continuity of contraceptive usage.

³National Programme for Family Planning & Primary Healthcare, *The Lady Health Workers Programme, 2010–2015, PC-1* (Islamabad: Government of Pakistan, Ministry of Health, 2010).

An appropriate constellation of services refers to the location of FP service delivery points at a given locality and their referral linkages.

ISO Certification

During 2004, the Standing Committee of the National Assembly desired that service delivery points of the Population Welfare Programme have ISO Certification so that their QoC would be recognized at par with the international standards and protocols. The programme's network of outlets is mandated to deliver FP services, keeping special focus on QoC. Quality assurance is regularly monitored at district, provincial, and federal levels.

List of Quality of Care Indicators

Provider

- Demonstrates good counselling skills.
- Treats client with respect/courtesy.
- Assures confidentiality.
- Asks client about reproductive choice.
- Discusses client's preference among contraceptive mix.
- Discusses methods for preventing pregnancy and STIs/RTIs, HIV/AIDS, and hepatitis through proper use of barrier methods.
- Tailors key information on the accepted method, explaining its use, side effects, and possible complications.
- Gives instructions on when to return for follow-up.
- Follows infection prevention and control procedures according to guidelines.
- Recognizes/identifies contraindications, consistent with guidelines.
- Performs clinical procedures according to guidelines.

Staff (other than provider)

- Treats clients with respect.
- Provides relevant information to assist clients in using the facility.

Client

- Participates actively in discussion and selection of method.
- Receives his or her method of choice.
- Believes the provider will keep his or her information confidential.

Facility

- Has all (approved) contraceptive methods available, with minimum stock for 3 months.
- Has basic equipment/items needed for delivery of methods offered by the facility (including sterilizing equipment, gloves, blood pressure apparatus, specula, adequate light source, adequate water supply, and sewerage).
- Ensures privacy for pelvic examination/IUCD insertion.
- Has sufficient flexibility to make local-level changes based on client feedback.
- Should undergo periodic supervisory visits within a certain pre-determined period.
- Has adequate storage of contraceptives and medicines (away from moisture, heat, direct sunlight) on premises.
- Follows standard clinical guidelines.
- Has comfortable waiting area and ensures minimum waiting time.

Checklists on QoC for Service Delivery Points

Checklist on Readiness for Handling Emergency Situation

A. Equipment

Sr. No.	Equipment	Availability		Functional	
		Yes	No	Yes	No
1.	Airway				
2.	Ambu bag/resuscitator				
3.	Laryngoscope				
4.	Endotracheal tube				
5.	Oxygen cylinder, regulator, and tubing				

B. Emergency Medicines List as per National Standards

Sr. No.	List Displayed	Yes	No
	Medicines being checked weekly with reference to:		
	• Availability		
	• Expiry		

List of Emergency Medicines attached at Annex IV.

Checklist on Segregation/Disposal of Infectious Waste (In Coloured Bags) and Non-Infectious Waste (In White Bags)

Sr. No.	Waste Disposal	Yes	No
1.	Segregation of infectious and non-infectious waste		
2.	Infectious waste disposed of in black bags to incinerator		
3.	Non-infectious waste disposed in white bags to the general waste		

Checklist on Infection Prevention Protocols Observed as per National Standards

Sr. No.	Method	In Practice		Knowledge	
		Yes	No	Yes	No
1.	Decontamination with 0.5% chlorine solution				
2.	Cleaning				
3.	High-level disinfection through boiling				
	Sterilization:				
	• Autoclave				
	• Manual pressure cooker				
	• Chemical sterilization				

Checklist on Client-Oriented Services

Sr. No.	Counselling	Knowledge		InPractice	
		Yes	No	Yes	No
1.	Greet				
2.	Ask/Assess				
3.	Tell				
4.	Help				
5.	Explain				
6.	Return/follow-up visit				

Insertion Room Checklist

Sr. No.	Insertions Room	Yes	No
1.	Housekeeping:		
	• Dusting		
	• Cleaning		
2.	• Things in order		
	Steps of infection prevention observed:		
	• Handwashing		
	• Handscrubbing		
	• Gloving		
	• Decontaminating:		
	– Insertion room table		
	– Couch		
3.	– Buckets		
	– Floor		
	Equipment:		
	• Boiler (sterilizer)		
	• Autoclave		
	Separately packed sterilized or HLD IUCD kits for individual clients:		
	• Insertion kits		
	• Removal kits		

Operating Theatre Checklist

Sr. No.	Operating Theatre	Observed		Frequency	
		Yes	No	Proposed	Practice
1.	Housekeeping			Twice daily	
2.	Decontamination with 0.5% chlorine solution			Twice daily	
3.	Cleaning			Twice daily	
4.	Carbolization			Quarterly	
5.	Ultraviolet light			Once daily	
6.	Sterilized or HLD functional Instrument availability			Not applicable	Not applicable
7.	Instruments in functioning order			Not applicable	Not applicable
8.	Soiled linen placed in a defined storage area (hampers)			Not applicable	Not applicable

Checklist on Calibration of Following Essential Equipment Used in RHS-A Centre

Sr. No.	Equipment	Calibration		Date of Calibration	Expiry Date
		Yes	No		
1.	Thermometer				
2.	Blood pressure apparatus				
3.	Weighing scale				
4.	Oxygen cylinder gauge				
5.	Autoclave gauge				

Checklist on Client Feedback

Sr. No.	Proforma	Yes	No
1.	Adequately filled		
2.	6-monthly analysis		
3.	Clients' feedback/suggestions incorporated accordingly for improvement of outlet (service delivery point)		

Checklist on Awareness of Quality Standards

Sr. No.	Auditable Areas From (Quality Management System)	Yes	No
1.	Quality policy and job description awareness		
2.	Quality objective update		
3.	Availability of counsellor's kit		
4.	Availability of consent forms		

Checklist of Contraceptive Mix

Sr. No.	Auditable Areas Form (Quality Management Systems)	Yes	No
1.	Availability of all contraceptives according to minimum stock level		
2.	Random checking of contraceptive client record		
3.	Monthly performance report of previous 6 months duly filled in		
4.	Proper storage of facility medicines in cool and dry place		

Checklist of HRD/Training/Records

Sr. No.	Auditable Areas Form (Quality Management Systems)	Yes	No
1.	Training record of previous 1 year		
2.	Payment record of contraceptive surgeries completely filled up		

Checklist on Maintenance of Infrastructure

Sr. No.	Auditable Areas Form (Quality Management Systems)	Yes	No
1.	Housekeeping (whitewash)		
2.	Sanitation		
3.	Leakages		

Emergency Medicine List

1.	Atropine Sulphate 1 mg/10 ml	5 ampoules
2.	Dopamine 400 mg/10 ml	2 ampoules
3.	Inj Dexamethasone 4 mg/ml	5 ampoules
4.	Inj Epinephrine 1:10000/ml	5 ampoules
5.	Inj Narcan 0.4 mg/ml	3 ampoules

2

COUNSELLING AND INFORMED CHOICE IN FAMILY PLANNING

Introduction

Counselling is one of the most important components of family planning (FP). It is the responsibility of service providers at all levels to offer effective counselling on FP methods in order to increase clients' satisfaction and ensure continuity in their method of choice.

Steps of Family Planning Communication

Communication is the process of sharing our ideas, thoughts, and feelings with other people and having those ideas, thoughts, and feelings understood by the people we are talking with. When we communicate we speak, listen, and observe.

Motivation

Motivation is a one-way process influencing the behavior of a person in a particular direction. Motivational activities are biased. They often attempt to influence an individual or a group. Motivation for FP is the process of bringing about an attitudinal change for creating awareness to accept the advantages of the contraceptives that the provider wants to offer. For example, a service provider explains the advantages of a method but does not explain its limitations. The information is biased and incomplete and influences the client.

Giving Information

Information-giving activities focus on providing facts about methods. The information presented may be complete or limited and may be correct or incorrect.

Counselling

Counselling is a two-way process in which unbiased information is given to the clients about all available methods so they can make a free, well-informed decision. FP counselling is the process of helping clients to make informed and voluntary decisions about the choice of contraceptives. The role of family planning counselling is to support a woman and her partner in choosing the method of family planning that best suits them and to support them

in solving any problems that may arise with the selected method. During late pregnancy, after giving birth and after an abortion, it is important that the woman or the couple receives and discusses correct and appropriate information so that they can choose a method which best meets their needs. Counselling focuses on the client's/patient's situation and needs.

Table 2-1. Family Planning/Reproductive Health Communication Activities

Activity	Goal	Content	Direction	Location
Motivation	Influencing behaviour in a particular direction	Propaganda or persuasion	One-way	Anywhere
Information Giving	Providing facts and raising awareness	Facts, complete or incomplete	One- or two-way	Anywhere
Counselling	A satisfied client having free and informed choice	Facts; Client's feelings and Motives	Two-way	Private

Principles of Good Counselling

- **Treat each client well.** All clients deserve respect, regardless of their age, marital status, ethnic group, sex, or sexual and reproductive health (RH) behaviour. (See "Greet".)
- **Interact.** Each client is a different person. Ask questions, listen, and respond to each client's own needs, concerns, and situation following MEC 2015. (See "Ask".)
- **Give the right amount of information.** Provide enough information for the client to make informed choices but not so much that the client is overloaded. Use IEC and reference material (See "Tell".)
- **Tailor and personalize information.** Give clients the specific information that they need and want, and help clients see what the information means to them. (See "Tell".)
- **Provide the FP method that the client wants.** Provide the method unless a valid medical reason prevents it. (See "Help".)
- **Help clients remember instructions.** (See "Explain".) Ask the client to return for follow-up. (See "Return".)

Frame Work of Counselling

Two approach

1. GATHER Approach
2. Balanced Counselling Strategy Plus.

GATHER Approach¹

FP counselling has six elements, which can be remembered by the word GATHER.

- G= GREET the client in a friendly and polite manner.
- A= ASK and assess the client's knowledge, needs, and feelings. Remove any doubts/concerns the client has and listen actively following MEC Wheel.
- T= TELL the client about all available FP methods with the help of samples, flip charts, leaflets, and brochures.
- H= HELP the client choose a method. A particular method may not be suitable for a particular client. Explain this clearly and help the client choose another method. If this method is not available, help by referring the person to a relevant facility.
- E= EXPLAIN the use of the chosen method. This would include how it should be used, its effectiveness, advantages and limitations, possible side effects, warning signs, and follow-up regime. To ensure that the client has understood, ask the client to repeat the information given. The client must also be informed of the warning signs for which return to the facility is important.
- R= RETURN/ REASSURANCE for follow-up. At the follow-up visit, inquire if the client is still using the method. If the answer is “yes”, ask if there are any problems or side effects; also confirm that the method is being correctly used. Give appropriate advice about any minor side effects, and refer for treatment if side effects are severe.

- In discussing contraceptive options with clients, the counsellor should briefly review all available methods, even if a client has a preference for a specific method. The counsellor should be aware of a number of factors about each client that may be important, depending on the method in question. These are:
 - Reproductive goals of the client or couple (spacing or timing births)
 - Personal factors including the time, travel costs, pain, or discomfort likely to be experienced
 - Accessibility and availability of other methods at referral facilities
 - The need for protection against STIs (e.g., hepatitis B and C, HIV/AIDS)

Counselling can be divided into three phases (following BCS plus algos)

- Initial counselling: all methods are described and the client is helped to choose the most appropriate method.
- Method-specific counselling prior to and immediately following service provision: the client is given instructions on how to use the method, and common side effects, warning signs, and follow-up regime are discussed.
- Follow-up counselling: during the return visit, use of the method, satisfaction with it, and any problem that may have occurred are discussed.

These important elements should be followed during counselling for every contraceptive method.

¹Adapted from: Gallen M, Lettenmaier C, and Green CP. 1987. Counseling makes a difference. Population Reports Series J(35): 1–31.

Balanced Counseling Strategy

Purpose of BCS Toolkit

The Balanced Counseling Strategy: A Toolkit for Family Planning Service Providers is designed to provide the information and tools needed for health care facility directors, supervisors, and service providers to implement the Balanced Counseling Strategy in their family planning services. The third edition of the BCS+ includes content updated according to the latest WHO Medical Eligibility Criteria (2015). It incorporates the most up to date evidence on clinical indications for the provision of family planning methods. The updated cards include instructions for providers, guiding them through supplemental counseling and services that family planning clients may need.

This toolkit includes the following:

- **BCS User's Guide** on how to implement the Balanced Counseling Strategy. It can be distributed during training on BCS or used on its own with the BCS job aids.
- **BCS job aids** comprising:
 - **The BCS algorithm** that summarizes the 11 steps needed to implement the Balanced Counseling Strategy during a family planning counseling session. These steps are organized under three stages of the consultation: pre-choice, method choice, and post-choice. During each stage of the counseling session, the provider is given step-by-step guidance on how to use the Balanced Counseling Strategy. Depending on the client's response to the questions posed, the algorithm outlines which actions to take. The BCS algorithm is on page 5 and can also be found with the job aids.
 - **Counseling cards** that the provider uses during a counseling session. There are 16 counseling cards. The first card contains 6 questions that the service provider asks to rule out if a client is pregnant (Stanback et al. 1999). The other 15 cards each contain information about a different family planning method. Each card has an illustration of the contraceptive method on the front side of the card. The back of the card contains a list of 5 to 7 key features of the method. It also describes the method's effectiveness, which is represented by a number and also written out.
- **Method brochures** on each of the 15 methods represented by the counseling cards. They are designed to help the client and provider narrow down the appropriate method for the client. The information in the method brochures follows the majority of family planning programming norms (Hatcher et al. 2004; WHO/RHR and JHU/CCP 2007). Once the client has selected a method, the provider gives the client a brochure about the method to take home.
- **BCS Trainer's Guide** that supervisors and others can use to train health care facility directors and service providers on how to use the Balanced Counseling Strategy for counseling family planning clients.

Algorithm for Using the Balanced Counseling Strategy Plus

Third Edition

Pre-Choice Stage	<ol style="list-style-type: none"> 1. Establish and maintain a warm, cordial relationship. 2. Inform client that there will be an opportunity to address other health needs after family planning needs are addressed. 3. Ask client about current family size, and current contraceptive practices. Counsel the client on Healthy Timing and Spacing of Pregnancy using counseling card. <ol style="list-style-type: none"> a. If client is currently using a family planning method, ask about her/his satisfaction with it and interest in continuing or changing the method. 4. Rule out pregnancy using the checklist card to be reasonably sure a woman is not pregnant 5. Display all of the method cards. Ask client if she/he wants a particular method. 6. Ask all of the following questions. Set aside method cards based on the client's responses. <ol style="list-style-type: none"> a. Do you wish to have children in the future? If "Yes," set aside vasectomy and tubal ligation cards. Explain why. If "No," keep all cards and continue. b. Have you given birth in the last 48 hours? If "Yes, set aside combined oral contraceptives (the Pill), combined injectables and progestin only injectables. Explain why. If "No," continue with next question c. Are you breastfeeding an infant less than 6 months old? If "Yes," set aside the combined oral contraceptives (the Pill and combined injectable cards. Explain why. If "No," or she has begun her monthly bleeding again, set aside Lactational Amenorrhea Method (LAM) card. Explain why. d. Does your husband support you in family planning? If "Yes," continue with the next question. If "No," set aside the following cards: female condom, male condom, Standard Days Method, Two Day Method and withdrawal. Explain why. e. Do you have any medical conditions? Are you taking any medications? If "Yes, ask further about which conditions or medications. Refer to WHO Medical Eligibility Criteria Wheel or current national guidelines and set aside all contraindicated method cards. Explain why. If "No," keep all the cards and continue. f. Are there any methods that you do not want to use or have not tolerated in past? If "Yes," set aside the cards the client does not want. If "No," keep the rest of the cards.
Method Choice stage	<ol style="list-style-type: none"> 1. Briefly review the methods that have not been set aside and indicate their effectiveness. <ol style="list-style-type: none"> a. Arrange the remaining cards in order of effectiveness (number on back of each card. b. In order of effectiveness (lowest number to highest), briefly review the attributes on each method card. 2. Ask the client to choose the method that is most convenient for her. 3. Using the method-specific brochure, check whether the client has any condition for which the method is not advised. <ol style="list-style-type: none"> a. Review "Method not advised if you..." section in the brochure. b. If the method is not advisable, ask the client to select another method from the cards that remain. Repeat the process from Step 8.

Post- choice stage	<ol style="list-style-type: none"> 1. Discuss the method chosen with the client, using the method brochure as a counseling tool. Determine the client's comprehension and reinforce key information. 2. Make sure the client has made a definite decision. Give her the method chosen, a referral, and a back-up method depending on the method selected. 3. Encourage the client to involve husband in decisions about practice of contraception through discussion or a visit to the clinic.
---------------------------	---

Systematic screening for other services stage	<ol style="list-style-type: none"> 1. Using information collected previously; determine client's need for postpartum, newborn, and infant care or well-child services. <ol style="list-style-type: none"> a. If client reported giving birth recently, review the Promoting Healthy Postpartum Period card and Promoting Newborn and Infant Health card with client. Provide or refer for services, if needed. b. For clients with children less than 5 years of age, ask if the children have been taken to well-child services. Provide or refer for immunizations and growth monitoring services, if needed. 2. Ask client when she had her last screening for cervical cancer (VIA or pap smear). <ol style="list-style-type: none"> a. If her last screening was more than 3 years ago (*6-12 months if she is HIV positive) or she doesn't know, ask if she would like to have a screening today. Review the Screening for Cervical Cancer card. Provide or refer for services. b. If her last screening was less than 3 years ago*, continue with next question. 3. Discuss STI/HIV transmission & prevention and dual protection with the client using the counseling cards. Offer condoms and instruct her in correct and consistent use. 4. Conduct STI and HIV risk assessment using the counseling card. If symptoms are identified, treat her syndromically. 5. Ask client whether she knows her HIV status. <ol style="list-style-type: none"> a. If client knows she is living with HIV, <ul style="list-style-type: none"> - Review Positive Health, Dignity, & Prevention counseling card with client. - Refer client to center for wellness care and treatment. b. If client knows s/he is HIV negative, <ul style="list-style-type: none"> -Discuss a timeframe for repeat testing. c. If client does not know her status, <ul style="list-style-type: none"> - Discuss HIV Counseling and Testing - Offer or initiate testing with client, according to national protocols. - Counsel client on the test results. d. If client is living with HIV, review Positive Health, Dignity, & Prevention counseling card and refer client to center for wellness care and treatment. 6. Give follow-up instructions, a condom brochure, and the brochure for the method chosen. Set a date for next visit. 7. Thank her for the visit. Complete the counseling session.
--	--

Benefits of Counselling

Counselling is a vital part of FP. It helps clients:

- Arrive at an informed choice of reproductive options;
- Select a suitable contraceptive method with which they are satisfied; and
- Use the chosen method safely and effectively.

Qualities of a Good Counsellor

Knowledge

A good counsellor should have knowledge of:

- Demographic context: national and global perspective
- Effects of rapid population growth on the socio-economic infrastructure of the country
- Follow FP Compliance policy in the country
- Government policies regarding population
- Influence of FP on the health of mother and child
- Common myths, misunderstandings, and misconceptions regarding FP and how they can be countered
- Local customs and traditions
- The human reproductive system (anatomy and physiology) Contraceptive technology update
- Client eligibility criteria, policies, and administrative procedures of the facility
- Concepts, principles, and goals of counselling
- Recordkeeping/reporting
- Follow-up/referral systems and procedures

Figure 2-1. Steps in Counselling

Initial Counselling

Client Reception

- Greet the client warmly and introduce yourself.
- Obtain basic information (name, address, etc.).

Counselling Area

- Ask about the client's reproductive goals and possible need for protection against STIs, including hepatitis B and C, HIV and AIDS. Ask if the client wants to space or limit births.
- Discuss the client's needs, concerns, and fears in a thorough and empathetic manner. Explore any attitudes or cultural or religious beliefs that either favour or eliminate one or more methods.
- Provide information about all contraceptive choices available and the risks and benefits for each. Help the client to choose an appropriate method.

Methods-specific Counselling

Counselling Area

Once the client chooses a method:

- Make sure that the client has no medical condition that would be a problem or require more frequent follow-ups.

- Clearly discuss the characteristics of the method, emphasizing the following points:
 - Effectiveness
 - Use
 - Convenience, comfort, and reversibility
 - Protection against STIs, including hepatitis B, C and HIV and AIDs
- Explain common side effects or problems associated with the method, especially changes in the menstrual bleeding pattern, and be sure they are fully understood.
- If the client is at risk for STIs, inform that use of a barrier contraceptive is a must.
- Correct doubts and misinformation about the method.

Procedural/Examination Area

- Review client assessment data to determine if the client is an appropriate candidate for the methods or if there is any problem that should be monitored more frequently while the client is using it.
- Counsel how to use the method and what to do if any problem or side effect arises. Special emphasis should be given to menstrual bleeding patterns.
- Provide information on warning signs, medical problems, and the need to return to the clinic immediately, should any occur.
- Assure that the client can return to the clinic at any time to receive advice and medical attention.
- Ask the client's questions.
- Complete the client's record.

Follow-up/return Visit Counselling (continuing Client)

Counselling/Examination

- If the client has problems, resolve them. This can include offering a new method or referring the client to an appropriate facility.
- Check whether the client is satisfied.
- Inquire about problems and respond to concerns about side effects or problems.
- Ask the client to repeat the instructions related to the selected method to confirm that the client understood well.

Skills

A good counsellor should be able to:

- Build up a good rapport with the clients.
- Deal with clients at their level of education and understanding.
- Show empathy.
- Deal tactfully with sensitive issues.
- Listen patiently to the client's point of view.
- Be discreet and maintain confidentiality.
- Pay full attention to the client's need.
- Help the client to make a decision.

Attitude

A good counsellor should:

- Have a positive attitude towards FP.
- Be unbiased towards different population groups.
- Give unbiased information on FP methods.
- Have a desire to work with people. Be punctual.
- Be a hard worker.
- Be pleasant and polite. Be helpful.
- Be attentive to the client's problems. Not ridicule the client over any issue.
- Show tolerance for values that differ from her/his own values.
- Be aware of factors that affect decision-making.
- Provide counselling in local languages.
- Be well-versed in the local language(s) of the client population.
- Show respect for the right and ability of people to make their own decisions.
- Be comfortable with issues related to human sexuality and people's expressions of their feelings.
- The provision of counselling should be part of every interaction with the client. Information and counselling commonly will come from more than one source. Therefore, all staff should be knowledgeable about all available contraceptive methods.

Counselling helps to establish a positive interpersonal relationship between service providers and clients. When providers treat clients as valued customers and give them good service by listening to, understanding, and responding to their needs, their clients are more likely to be satisfied. When clients are satisfied with their treatment at a clinic, they will tell their friends and relatives about their good experience (and conversely, if they are dissatisfied they will pass along their bad experience, too).

Standards of a Good Counsellor

Effective counselling focuses on the client's individual needs and situation. Good counsellors are willing to listen and respond to the client's questions and concerns. The good counsellor:

- Understands and respects the client's rights.
- Earns the client's trust.
- Understands the benefits and limitations of all contraceptive methods.
- Understands the cultural and emotional factors that affect a client's or a couple's decision to use a particular contraceptive method.
- Encourages the client to ask questions.
- Uses a non-judgemental approach that shows the client respect and kindness.
- Presents information in an unbiased, client-sensitive manner.
- Listens to the client's concerns actively.
- Understands the effect of nonverbal communication.

- Recognizes when to refer the client to an appropriate facility.
- Attends to the client as quickly as possible.

Guidance Tools Can Improve Counselling

Using audiovisual aids, such as flip charts, can help providers communicate effectively with the clients and tailor information according to clients' individual situations and needs at both the initial and return visits. Checklists can be a useful screening tool for health care providers in resource-poor settings.

Instructions to the Counsellor

Give Information Clearly so That the Clients Understand

- Use simple words and short sentences in a language the client understands.
- Use pictures and models adapted to the local culture.
- Show samples of different contraceptives, and let the client handle them.
- Stop from time to time to ask if the client has understood.
- Ask if the client has any questions.
- Repeat instructions.
- Ask the client to repeat the instructions.
- Give the client written or printed information to take home.

Counsellor's Kit

- Diagrams of male and female reproductive anatomy/modules/flip chart
- Samples of all available contraceptive methods
- A checklist of the minimum information that all clients should receive
- A leaflet on common questions and answers about Islam and FP
- A list of referral outlets
- A list of contra-indications for all method
- Algorithm for BCS Plus
- Counselling cards for BCS Plus.
- Brochures for Client

Informed Choice

Informed choice means that a person freely makes a carefully considered decision based on accurate, useful information. An important purpose of FP counselling is to help the client make informed choices about FP and RH.

“Informed” means that:

- Clients have the clear, accurate, and specific information required to make their reproductive choices, including a choice among FP methods.
- Good-quality FP programs explain each FP method as needed, without overloading

clients with information, and helping clients to use each method effectively and safely.

- Clients understand their own needs because they have thought about their own situations through interpersonal communication and through mass-media messages.
- “Choice” means that:
- Clients have a range of FP methods to choose. Health care providers offer different methods to suit clients' needs. If a method cannot be provided, then the clients are referred to another facility.
- Clients make their own decisions. Counsellors help the clients think through their decisions, but do not persuade the clients to make a certain choice.

Informed Consent

Informed consent is the client's voluntary decision to opt for any contraceptive after receiving all relevant information regarding the requested method. Special care should be taken when a client is:

- Pregnant, and specifically, consent should not be obtained when a woman is in labour
- Mentally retarded

Client Assessment

The primary objectives of assessing a clients prior to providing FP services are to determine:

- That the client is not pregnant;
- Whether any conditions requiring precaution exist for a particular method; and
- Whether there are any special problems that require further assessment, treatment, or regular follow-up.

This information usually can be determined by asking a few key questions. Unless specific problems are identified, the safe provision of most contraceptive methods, except IUCDs and voluntary sterilization, does not require performing a physical or pelvic examination because:

- The currently available low-dose combined (oestrogen and progestin) contraceptives, such as combined oral contraceptives (COCs) and combined injectable contraceptives (CICs), are quite safe.
- Progestin-only implants, injectables, and pills are free of oestrogen-related effects, and the amount of progestin delivered per day is lower than with COCs.

With the exception of condoms, no contraceptive method provides protection against STIs (e.g., hepatitis B and C, HIV/AIDS). All clients should be made aware of the risks of STI transmission.

How to Be Reasonably Sure That the Client Is Not Pregnant

One can reasonably be sure that a client is not pregnant if there are no signs or symptoms of pregnancy (e.g., breast tenderness or nausea) and she:

- Has not had intercourse since her last menses; or
- Has been correctly and consistently using a reliable contraceptive method; or within the first 7 days after the start of menses (days 1–7); or
- Is within 4 weeks postpartum (for non-breastfeeding women); or within the first 7 days postabortion; or
- Is fully breastfeeding, less than 6 months postpartum, and has had no menstrual bleeding yet.
- Have you abstained from unprotected [no method of FP] sex since your last menstrual bleeding or delivery?

When a woman is more than 6 months postpartum, the health care provider can be reasonably sure that the client is not pregnant if:

- Breastfeeding frequency is kept high;
- She has no menstrual bleeding (amenorrhoeic); and
- No clinical signs or symptoms of pregnancy are present.

Pelvic examination is seldom necessary, except to rule out pregnancy of greater than 6 weeks, measured from the last menstrual period (LMP).

Pregnancy testing is unnecessary except in cases where:

- It is difficult to confirm pregnancy (i.e., 6 weeks or less from the LMP); or
- The results of the pelvic examination are equivocal (e.g., the client is overweight, making sizing the uterus difficult).

In these situations, a sensitive urine pregnancy test may be helpful, if readily available and affordable. If pregnancy testing is not available, counsel the client to use a temporary contraceptive method like condoms or abstain from intercourse until menses occurs or pregnancy is confirmed.

Counseling of Clients with Special Needs

FP offers freedom from fear of unplanned pregnancy and can improve sexual life, partner relations, and family well-being. Many contraceptive methods are available, including methods that are short or long-acting, permanent or reversible, hormonal or non-hormonal, and for use by women or men. When properly provided and used, currently available contraceptives are safe and effective for the vast majority of users.

Most healthy women are eligible to use any method of contraception and can select a method that best meets their needs. As a woman moves through the different stages of reproductive life, her contraceptive needs and her health status may change. Not all

methods are equally acceptable at each stage of a woman's life. Adolescents, postpartum and postabortion women, breastfeeding women, and women over the age of 35 are groups with special contraceptive and counselling needs.

Youth Friendly Services:

For youth, services should be

- **EQUITABLE:** All youth, not just certain groups, will have equal access to the health services they need.
- **ACCESSIBLE:** Youth are physically able to obtain the services that are provided (i.e., services are provided at times and in places that are accessible to all young people).
- **ACCEPTABLE:** Health services are provided in ways that meet the expectations of young people.
- **APPROPRIATE:** The health services provided are those that young people need and are appropriate for young people at their various stages of life (i.e., young adolescence, older adolescence and young adulthood).
- **EFFECTIVE:** The right health services are provided in the right way and make a positive contribution to young people's health.
- **GENDER EQUITABLE:** Services are safe, affordable and accessible for young women and young men, within a context that promotes the rights of women and girls to make decisions and determine their life outcomes

Youth-friendly service for a youth will:

- Involve youth in program design
- Use youth role models/peer educators
- Welcome men and women
- Offer couples counseling/support groups
- Link with institutions that also work with married young people
- Train staff to understand the complexity of early marriage and how to work with married youth
- Encourage couples to visit the clinic together
- Provide information and services for family planning
- Provide information and services for safe motherhood
- Provide information and education about healthy spacing and timing of pregnancy

Annex: Facility Observation Tool for Youth Friendly Services

This question guide can be used to assess the clinic needs and capacity for youth friendly services. Information can be collected through a combination of observations and individual interviews with service providers.

Facility Observation Tool	Yes/No/NA	Comments
Are any young people excluded from services at this facility?		
Does the facility provide information about where young people can access other youth friendly health or social services in the community?		
Is the facility open during hours that are convenient to youth?		
Is the facility located in an area that is accessible to youth and safe for them to travel to?		
Are services free of cost or affordable for young people?		
Does the facility have posters, brochures and other IEC materials that target young people, including information about their rights?		
Are young people greeted warmly upon entering? <i>All staff demonstrate respect and concern for young people?</i>		
In the reception and waiting areas, is it possible to hear conversations between receptionist and clients?		
Is there a confidentiality policy and non-disclosure policy in place?		
Are sessions conducted in an area that provides privacy so that nobody can see or hear the conversations taking place?		
Are there separate clinic hours or waiting areas just for young people?		
Are youth referred to specific providers that have appropriate background/training?		
<i>Does adequate time is allocated for client and provider interaction?</i>		
<i>Are there any Peer counselors available at the facility?</i>		
Does the facility have a youth-friendly strategy or action plan in place?		
Is there a confidential mechanism for youth to provide feedback?		

Adolescents

Adolescents who are married need access to safe and effective contraception. Many adolescents use no contraception or use a method irregularly, so they are at high risk of unwanted pregnancy, unsafe abortion, and STIs. In general, adolescents are eligible to use any method of contraception. Services should avoid unnecessary procedures that might discourage or frighten teenagers, such as requiring a pelvic examination when they request contraceptives.

Postabortion Women

Women who recently have had an abortion have special RH needs that influence their contraceptive options. Counsellors should be aware of these health issues so that they can provide appropriate counselling. Most important are the postabortion women who may face immediate, acute, and possibly life-threatening medical problems. Women with abortion-related complications need immediate medical attention as well as appropriate information and counselling with respect to FP once their condition has stabilized.

Postpartum Women

Women who recently have given birth also have special RH needs that influence their contraceptive options. In postpartum women, return to fertility is influenced by whether the woman is breastfeeding. In women who are not breastfeeding, the first postpartum ovulation may occur at any time from day 21 to day 90 after delivery. Women who are not breastfeeding or who have weaned their infants are eligible to use any contraceptive method, provided that there are no delivery-related complications and they are screened for any existing health conditions.

Breastfeeding Women

Women who are breastfeeding also have special health needs and concerns. They should not use a contraceptive method that will affect breast milk or the health of the infant, such as a combined oral contraceptive pill or combined injectables. These methods should be delayed until after 6 months. According to MEC 2015 Progestin-only pills and Implants can be offered to the women immediately after the delivery and an IUCD may be inserted either within 48 hours of delivery or after 4-6 weeks postpartum.

Women over Age 35

Although many women achieve the desired family size by the time they reach 35 years, women remain fertile until menopause, which generally occurs between the ages of 45 and 55 years. Contraception is recommended until 1 year after the menstrual cycle ceases. In addition, women over age 35 may need protection against STIs, including HIV. Access to appropriate and acceptable contraceptives is important for women in the later

reproductive years because pregnancy after age 35 carries increased health risks for both the woman and child. A woman's choice and use of contraceptives during this time may be influenced by whether she wants more children, has health problems (such as diabetes, hypertension, anaemia, or genital tract disorders), or smokes, as well as by her previous experience with contraceptives. For women who are experiencing uncomfortable menopausal symptoms, oestrogen-containing hormonal methods may be a good choice, as they can alleviate some symptoms. Because older women are more likely to have pre-existing health problems, FP programmes should provide careful screening and counselling for these women when providing contraception.

Services for Clients with Chronic Health Problems

Clients with chronic or serious health problems still need access to safe and effective contraception. Providing an appropriate contraceptive method for these clients can be complicated since the health condition may limit the contraceptive choices. The counsellor must know about possible interactions among medical conditions, drugs, and contraceptives, and must be able to provide appropriate counselling. Women who have chronic or serious medical conditions may need medical follow-up and monitoring more often than other women. In balancing the needs and desires of the client, counsellors must consider that, for women with serious health conditions that make pregnancy dangerous, providing no contraceptive method would be even more dangerous than providing a method with minor side effects. Issues of mentally handicapped clients also need to be addressed through proper counselling of their spouses and family members.

Contraception for HIV-Infected Women

Women infected with HIV face a variety of RH decisions involving their desire for pregnancy, their contraceptive practices, and choices and decisions if an unintended pregnancy occurs. HIV-infected women should be allowed to make these decisions freely. Interventions to offer voluntary FP can give these women more control over their reproductive lives and serve as a strategy to prevent perinatal HIV infection. Follow the MEC Wheel 2015 in making decision.

Male condoms, used consistently and correctly, are effective in preventing HIV transmission if either partner is infected with HIV. Female condoms also offer significant protection from STIs, but their use has been limited by cost and user acceptability. Other methods of contraception such as hormonal contraceptives and IUCDs are effective in preventing unplanned pregnancies, but do not prevent HIV transmission.

Special Needs of Abused Women

Abused women clearly have special needs, including medical, psychological, and legal support, and safe housing for themselves and their children. To be effective, solutions must acknowledge the whole problem. Health care planners and other health care providers are

in an excellent position to intervene because they represent one of the few institutions to come in contact with most women during their reproductive lives, the time of highest risk for domestic violence. FP providers must become aware of power imbalances and the resulting health effects. They cannot do their jobs effectively without being concerned about how the issue of power affects women's RH.

The most important contraceptive service for women in violent relationships is counselling, which must include recognition of the woman's difficulties with her partner and help in choosing a method that will not make those difficulties worse. Ideally, it will include referral or in-house professional counselling regarding violence issues and the resources available in the community.

Battered women who cannot protect themselves from STIs through condom use may need repeated screening and treatment for STIs. Emergency contraception is also a pressing need for many battered women.

Counselling Men

Men have special counselling needs and should receive special attention from health care providers to motivate them to make responsible choices regarding RH practices.

Men's Special Counselling Needs

- Men should be encouraged to support women's use of FP methods or to use FP methods themselves.
- It is important to talk to young men about responsible and safe sex before they become sexually active.
- Men often have less information or are more likely to be misinformed about FP methods, male and female anatomy, and reproductive functions because they tend to talk less about these issues than women.
- Men are often more concerned about sexual performance and desire than women.
- Men often have serious misconceptions and concerns that FP methods will negatively affect their sexual pleasure and/or performance.
- Men are often concerned that women will become promiscuous if they use FP.
- Many men do not know how to use condoms correctly. Health care providers should always demonstrate correct condom use, using a model when possible.
- Men are often not comfortable going to a health facility, especially if it serves women primarily.

Encourage men to participate in FP. Involving men can be crucial to a continuing client strategy. Men are more likely to support continued contraceptive use when they participate. Group Counselling/ Mohalla meetings could be good forum for engaging men in FP.

Counsellors can involve men and serve them better if they take four steps:

- Offer men FP and other RH services.
- Provide men with accurate information about FP.
- Explain how men can assure their own RH as well as that of their partners.
- Encourage couples to talk to each other about FP, as well as talking to health care providers.

Counsellors can often encourage men to talk with their partners about practicing FP and sharing decision-making by appealing to their sense of responsibility in family matters.

Rumours and Misconceptions

Rumours are unconfirmed stories that are transferred from one person to another by word of mouth. In general, rumours arise when:

- An issue or information is important to people, but it has not been clearly explained.
- There is nobody available who can clarify or rectify the incorrect information.
- The source of the rumour is perceived to be credible.
- People are motivated to spread them for political reasons.

A misconception is a mistaken interpretation of ideas or information. If a misconception is imbued with elaborate details and becomes a fanciful story, then it acquires the characteristics of a rumour.

Methods for Counteracting Rumours and Misconceptions

- When a client mentions a rumour, always listen politely. Do not ridicule her/ him.
- Define what a rumour or misconception is.
- Find out where the rumour came from and talk with the people who started it or repeated it. Check whether there is some basis for the rumour.
- Explain the facts.
- Use strong scientific facts about FP methods to counteract misinformation.
- Always tell the truth. Never try to hide side effects or problems that might occur with various methods.
- Clarify information with the use of demonstrations and visual aids.
- Give examples of people who are satisfied users of the method (only if they are willing to have their names used). This kind of personal testimonial is most convincing.
- Reassure the client by examining and informing her/him about the findings.
- Counsel the client about all available FP methods.
- Reassure and let the client know that further care will be provided through home visits.

Relationship between Contraceptive Methods and Sexual Life

FP has much to do with sexual life and health protection and is not restricted to decisions relating to procreation. Any member of the community who is of reproductive age should be considered a potential FP client.

FP services are a type of preventive health service. Therefore, the rights of FP clients should be seen in the overall context of the rights of the clients for any health services.

The Rights of Family Planning Clients

Right to Information

All individuals in the community have a right to information about the benefits of FP for themselves and for their families.

Right to Access

All individuals in the community have a right to receive services from FP programmes, regardless of their social status, economic situation, religion, political belief, ethnic origin, marital status, geographical location, or any other group identity.

Right of Choice

Individuals and couples have the right to decide freely whether or not to practice FP. A client's concept of acceptability and appropriateness changes with circumstances. Therefore, the right of choice also involves clients' decisions concerning discontinuation or switching of method.

Right to Safety

Family planning clients have a right to safety while practicing FP. This right to safety implies the following:

- Clients have a right to protection against any possible negative effect of a contraceptive method on their physical and mental health.
- Since unwanted pregnancies may represent a risk to health, the right of the client to safety also includes the right to effective contraception.
- When receiving FP services, clients also have a right to protection against the possibility of acquiring infection from contact with a contaminated instrument.

Right to Privacy

When discussing needs or concerns, the client has a right to an environment in which she/he feels confident and relaxed. Auditory and visual (during examination) privacy should be ensured.

Right to Confidentiality

The client should be assured that any information disclosed or any details of the services received will not be communicated to others without consent.

Right to Dignity

FP clients have a right to be treated with courtesy, consideration, and attentiveness, and with full respect of their dignity, regardless of their level of education and social status.

Right to Comfort

The client has a right to comfort. This right of the client is intimately related to adequacy and quality of services (e.g., service delivery sites should have proper ventilation, lighting, seating, and toilet facilities). The environment in which the services are provided should be in keeping with the cultural values, characteristics, and demands of the community.

Right of Continuity

Clients have a right to receive contraceptive services and supplies for as long as they need them. The services provided to a particular client should not be discontinued unless the decision is made jointly between the counsellor and the client.

Right of Opinion

Clients have the right to express their positive or negative views (thanks or complaints) about the quality of services they receive at the facility.

Table 2-2. Comparative Statement of Failure Rate of Different Contraceptives in First Years of Use¹

Family Planning Method	First-Year Pregnancy Rates (Trussell ^a)		12-Month Pregnancy Rates (Cleland and Ali ^b)
	Consistent and Correct Use	As Commonly Used	As Commonly Used
Implants	0.05	0.05	
Vasectomy	0.1	0.15	
Levonorgestrel IUCD	0.2	0.2	
Female sterilization	0.5	0.5	
Copper-bearing IUCD	0.6	0.8	2
Lactational amenorrhoea method (LAM) (for 6 months)	0.9	2	
Monthly injectables	0.05	3	
Progestin-only injectables	0.3	3	2
Combined oral contraceptives	0.3	8	7
Progestin-only oral pills	0.3	8	
Combined patch	0.3	8	
Combined vaginal ring	0.3	8	
Male condoms	2	15	10
Ovulations method	3		
TwoDay Method	4		
Standard Days Method	5		
Diaphragms with spermicide	6	16	
Female condoms	5	21	
Other fertility awareness methods		25	24
Withdrawal	4	27	21
Spermicides	18	29	
Cervical cap	26 ^b 9 ^a	32 ^b 16 ^a	
No method	85	85	85

a Trussell J. Contraceptive efficacy. In: Hatcher R et al., eds. 2007. Contraceptive Technology, 19th revised ed. Rates for monthly injectables and cervical cap are from Trussell J. Contraceptive failure in the United States. 2004. Contraception 70(2): 89–96.

b Cleland J and Ali MM. 2004. Reproductive consequences of contraceptive failure in 19 developing countries. Obstetrics and Gynecology 104(2): 314–320

KEY

 0-0.9
Very effective

 1-9
Effective

 10-25
Moderately effective

 26-32
Less effective

¹Source: World Health Organization Department of Reproductive Health and Research (WHO/RHR)

3

HEALTHY TIMING AND SPACING OF PREGNANCY

Introduction

Healthy Spacing of Pregnancies

In June 2005, the World Health Organization (WHO) brought together over 30 technical experts to review the available global scientific evidence regarding healthy intervals between pregnancies. The following recommendations are based on the results of this technical consultation:

After a live birth, a woman should **wait at least 24 months** (but not more than 5 years) before attempting the next pregnancy to reduce the risk of adverse maternal, perinatal and infant outcomes. Women should plan a healthy birth-to-birth interval of about 36 months, or 3 years, between children.

After a miscarriage or induced abortion, a woman should **wait at least 6 months** before attempting the next pregnancy to reduce the risk of adverse maternal, perinatal and infant outcomes.

Adolescents should delay first pregnancy until at least 18 years of age to reduce the risk of adverse maternal, perinatal and infant outcomes.

Every woman and every maternal/newborn health or family planning worker should know and understand the key recommendations for healthy spacing of pregnancies. (Specific messages related to the healthy spacing of pregnancies are presented in Appendix A.)

Key Terminology: To be able to counsel women and families effectively about healthy spacing of pregnancies, providers must clearly understand several terms.

Birth-to-pregnancy interval: Time period between a live birth and start of the next pregnancy.

Birth-to-birth interval: Time period between a live birth and the next live birth. When reviewing scientific studies or technical messages, health professionals can convert a birth-to-pregnancy interval to a birth-to-birth interval by adding 9 months to a year.

Key Research Findings about the Risks of Closely Spaced Pregnancies

Short birth intervals are associated with multiple adverse outcomes for mothers and newborns, including increased maternal and newborn death rates.

An infant born after a short birth interval has increased chances for:

- pre-term birth
- Having below normal weight at birth
- Being small for gestational age
- Neonatal Mortality

A woman who becomes pregnant too quickly following a previous birth/ miscarriage or induced abortion faces higher risks of:

- Anaemia
- Premature rupture of membranes
- Abortion
- Miscarriage
- Death

Early pregnancy (when the mother is younger than age 18) is associated with an increased risk of health complications for mothers and newborns, compared to women ages 20-24 years old. Adolescent mothers ages 15-19 are twice as likely to die during pregnancy or childbirth as those over 20; and girls below the age of 15 are five times more likely to die.

Factors That Contribute to Short Birth Intervals

Given the unmet need for family planning and prevalence of shorter-than-recommended birth intervals, women and their health care providers should understand the factors that contribute to the high risk of unintended pregnancy among postpartum women.

Return to Fertility

Postpartum women are frequently fertile again before they realize it. A woman will ovulate before she begins regularly menstruating again. And the chance of a woman's fertility returning before menstruation resumes increases as the postpartum period extends.

An individual woman's return to fertility cannot be predicted. Most non-breastfeeding women experience menses return within 4 to 6 weeks. Breastfeeding delays the resumption of ovulation and the return of menses, but it cannot be relied upon for contraceptive protection unless the woman is practicing LAM (further discussed on the following page).

Women often initiate family planning after their menstruation resumes. Individual studies appear to draw a correlation between return of menses and initiation of

contraceptive use and suggest that family planning-if used at all during the postpartum period-is most likely to be initiated in the month following the return of menses, which is often too late. 1 In one study, 8%-10% of women who were still experiencing postpartum amenorrhea conceived.

Resumption of Sexual Activity

Reported return to sexual activity after a birth varies greatly. A recent study of 17 developing countries looked at percentages of couples returning to sexual activity by 3 to 5.9 months. At one end of the range is Guinea, where about 10% of women have resumed sexual activity within that timeframe; at the other end are Bangladesh and Rwanda, where almost 90% of women are having sex again by 6 months.¹⁴

Postpartum abstinence, in countries that practice it, is not always strictly observed. Qualitative research has indicated that even among those countries practicing postpartum abstinence, sexual activity may occur irregularly early, on gradually progressing to more regular activity.

Women may be unwilling to ask for contraception “too soon” after birth. If a woman resumes sexual activity sooner after the birth than is deemed appropriate in her culture, she may assume that the provider will judge her if she asks for contraception. As a result, the woman may forego contraception even though this will put her at risk for unintended pregnancy.

Country Profile: Pakistan and Birth Spacing

Approximately one in three births in Pakistan occurs less than 24 months after a previous birth. The shortest birth interval (21 months) occurs among women ages 15–19, who are already at the highest risk of pregnancy-related complications.² These short intervals have important implications for maternal and child health.

Policy

Information about optimal birth spacing as well as the benefits of HTSP and the need for timely initiation of a family planning (FP) method after childbirth, miscarriage, or abortion will be incorporated with health education, counselling, and service delivery for women and their families wherever they receive medical care. These health care sites include FP clinics, antenatal clinics, birthing facilities, postpartum and postnatal care facilities, and other facilities like Basic Health Units (BHUs), Family Welfare Centres (FWCs) and CMWs birthing houses where mothers and children receive routine health care.

Standards

The following standards will be observed:

- The client will be given full information about optimal pregnancy spacing and the

benefits of HTSP as a part of FP health education and counselling. The importance of timely initiation of an FP method after childbirth, miscarriage, or abortion will be emphasized.

- The client's right to make a free and informed choice regarding eventual family size and fertility will be respected.

Rationale

Closely spaced pregnancies are associated with higher maternal and neonatal mortality rates as well as higher mortality rates among infants and older children under age 5.

Many women would prefer to avoid pregnancy but are not using any form of FP. These women are considered to have an “unmet need” for FP. In Pakistan, 64 percent of women in the first year postpartum have an unmet need for FP. Only 22 percent are using any method of FP during the first year postpartum, and only 12 percent of women desire another birth in the next 2 years.³

The Difference between “Birth Interval” and “Interpregnancy Interval”

The **birth-to-birth interval** (or birth interval) is the length of time from the birth of one baby until the birth of the next baby.

The **interpregnancy interval** (or “birth to pregnancy”) is the length of time from the birth of one baby to the conception of the next baby.

It is easiest to discuss HTSP with women using the birth to pregnancy interval, i.e., how long to wait before trying to get pregnant again.

Important Definitions	
Perinatal period	From the 20 th week of pregnancy to 28 days of life
Neonatal period	The first 28 days of a newborn's life; synonymous with “newborn”
Infant	From 28 days-1 year of life

Benefits of HTSP for Newborns and Infants

- Lower risk of stillbirth
- Lower risk of neonatal death
- Lower risk of preterm birth
- Lower risk of low birth weight
- Lower risk of being small for gestational age
- Extended interval of breastfeeding associated with improved nutrition

Benefits of HTSP for Mothers

- Lower risk of maternal death
- Lower incidence of induced abortion
- Lower risk of third trimester bleeding and premature rupture of membranes
- Lower risk of postpartum endometritis
- Lower risk of miscarriage
- Lower risk of anaemia
- Allows for 2 years of breastfeeding, which is linked with a reduced risk of breast and ovarian cancer

Benefits of HTSP for Delaying Early Childbearing among Adolescents

- Lower risk of maternal death (Adolescents ages 15–19 are twice as likely to die during pregnancy or childbirth as those over 20; and girls below the age of 15 are five times more likely to die.)
- Lower incidence of induced abortion
- Lower incidence of pregnancy- and delivery-related complications such as premature labor, low birth weight newborns, pre-eclampsia, and fistula, which are more common among adolescent mothers

Key HTSP Messages during Family Planning Counselling

- Benefits of pregnancy spacing after a live birth.
- Benefits of pregnancy spacing after a miscarriage or induced abortion.
- Benefits of older age at first pregnancy.
- Importance of initiating an FP method soon after childbirth, miscarriage, or abortion. Fertility may return as early as 3 weeks after delivery for women who are not exclusively breastfeeding and as early as 2 weeks after miscarriage or abortion.

Women who are practicing the lactational amenorrhoea method (LAM) should make a transition to another FP method before the baby is 6 months old.

Figure 3-1. HTSP Messages for Different Situations and Clients

<p>For couples who desire a next pregnancy after a live birth, the messages are:</p>	<p>For couples who decide to have a child after a miscarriage or abortion, the messages are:</p>	<p>For adolescents, the messages are:</p>
<p>For the health of the mother and the baby, wait at least 24 months, but not more than 5 years, before trying to become pregnant again.</p> <p>Consider using an FP method of your choice during that time.</p> <p>If you are not exclusively breastfeeding, return to fertility may occur within 4-6 weeks of childbirth. Consider starting an FP method shortly after birth.</p> <p>If you are practicing LAM, fertility may return when: The baby is 6 months of age, OR You are no longer exclusively breastfeeding, OR Your menses has returned.</p> <p>Consider starting an FP method before the baby is 6 months old.</p>	<p>For the health of the mother and the baby, wait at least 6 months before trying to become pregnant again.</p> <p>Consider using an FP method of your choice during that time.</p> <p>Fertility may return as early as 2 weeks after a miscarriage or abortion. Consider starting an FP method immediately after miscarriage or abortion.</p>	<p>For your health and your baby's health, wait until you are at least 18 years of age before trying to become pregnant.</p> <p>Consider using an FP method of your choice until you are 18 years old.</p>

Counselling Skills for HTSP

The table below describes the counselling skills and strategies to be used by the counsellor for different types of clients or client visits.

Table 3-1. HTSP Counselling Strategies for Different Types of Clients¹

Client Type	Usual Counselling Tasks
Returning clients with no problems	<ul style="list-style-type: none"> ■ Provide more supplies or routine follow-up. ■ Ask a friendly question about how the client is doing with the method. ■ Assess her intentions with regard to becoming pregnant; remind her of the benefits of HTSP, as appropriate.
Returning clients with problems	<ul style="list-style-type: none"> ■ Understand the problem and help resolve it. ■ Help the client choose another method, if she so desires, so that she does not discontinue the use of her method and risk an unplanned or closely spaced pregnancy. ■ Remind her of the importance of using an FP method of her choice to ensure HTSP.
New clients with a method in mind	<ul style="list-style-type: none"> ■ Check that the client's understanding of the method is accurate. ■ Support the client's choice, based on your assessment of the client's situation and if the client is medically eligible for the method. ■ Discuss how to use the method and how to cope with any side effects. ■ Discuss the health benefits of HTSP specific to her situation (e.g., delay to age 18, spacing postpartum or postabortion) and how FP can help her maintain her health and ensure healthy pregnancies.
New clients with no method in mind	<ul style="list-style-type: none"> ■ Discuss the client's situation, where she is in her reproductive cycle, her plans (such as fertility intentions and desired family size), and what is important to her about a method. ■ Help the client consider methods that might suit her particular situation. If needed, help her reach a decision. ■ Support the client's choice, give instructions on use, and discuss how to cope with any side effects. ■ Discuss the health benefits of HTSP specific to her situation (e.g., delay to age 18, spacing postpartum or postabortion) and how FP can help her maintain her health and ensure healthy pregnancies.

²Adapted from: World Health Organization Department of Reproductive Health and Research (WHO/RHR) and Johns Hopkins Bloomberg School of Public Health/Center for Communications Programs (CCP), INFO Project. 2007. Family Planning: A Global Handbook for Providers. CCP and WHO: Baltimore and Geneva.

4

ASEPSIS/INFECTION PREVENTION IN FAMILY PLANNING

Introduction

Infection prevention and infection control are fundamental to the success of any family planning (FP) program that offers a variety of options to its clients, ranging from IUCD insertion/removal, injectables, and implants to surgical contraception.

To prevent infection, remember that expensive, sophisticated equipment is not essential. A simple procedure such as handwashing, or using protective gloves before handling contaminated instruments or soiled linen, is effective in preventing or reducing the risk of spreading infection. Likewise, inexpensive equipment and facilities can provide a safe environment for performing FP procedures, including surgery. An example is the drastic reduction in the risk of all types of hepatitis viruses and HIV transmission by decontamination of table surfaces, gowns, gloves, and instruments with the use of chlorine solution. High-level disinfection (HLD) preceded by decontamination and proper cleaning is acceptable only where autoclaving is not possible.

Standard Precautions

The key components of Standard Precautions and their use are outlined in the box on the next page. Placing a physical, mechanical, or chemical barrier between micro-organisms and an individual or a client is a highly effective means of preventing the spread of infections. For example, the following actions create protective barriers for preventing infections and provide the means for implementing the new Standard Precautions:

- **Consider every person** (client or staff) as potentially infectious and susceptible to infection.
- **Wash hands**, the most important procedure for preventing cross-contamination (person to person or contaminated object to person).
- **Wear gloves** (both hands) before touching anything wet, broken skin, mucous

membranes, blood or other body fluids, or soiled instruments and contaminated waste materials, or before performing invasive procedures.

- **Use physical barriers** (protective goggles, face masks, and aprons) if splashes and spills of any body fluids (secretions and excretions) are likely (e.g., cleaning instruments and other items).
- **Use antiseptic agents** for cleansing the skin or mucous membrane prior to surgery, cleaning wounds, or doing hand rubs or surgical hand scrubs with an antiseptic product.
- **Use safe work practices** such as not recapping or bending needles, safely passing sharp instruments, and suturing with blunt needles.
- **Safely dispose of infectious waste materials** to protect those who handle them and prevent injury or spread of infection to the community.

Standard Precautions: Key Components¹

Handwashing (or using an antiseptic hand rub):

- Before and after client and patient contact
- After touching blood, body fluids, secretions, excretions, and contaminated items
- Immediately after removing gloves
- After examining each client/patient

Gloves:

- For contact with blood, body fluids, secretions, and contaminated items, mucous membranes, and broken skin

Masks, goggles, face masks:

- Protect eyes, nose, and mouth when contact with blood and body fluids is likely

Gowns:

- Prevent infection by minimizing shedding/contamination from provider (shedding of dead skin, micro-organisms and dirt carried by clothes)
- Protect skin from blood or body fluid contact
- Prevent soiling of clothing during procedures that may involve contact with blood or body fluids

Linen:

- Handle soiled linen in a manner that prevents it from touching skin or mucous membranes

Client care equipment:

- Handle soiled equipment in a manner that prevents contact with skin or mucous membranes and prevents contamination of clothing or the surrounding area
- Clean reusable equipment prior to use

Environmental cleaning:

- Clean and disinfect equipment and furnishings in client care areas

¹Adapted from: Tietjen L, Bossemeyer D, and McIntosh N. 2003. *Infection Prevention Guidelines for Healthcare Facilities with Limited Resources*. Jhpiego: Baltimore, Maryland.

Client resuscitation:

- Use mouthpieces/gauze, resuscitation bags, or other ventilation devices to avoid infection during mouth-to-mouth resuscitation

Client placement:

- Clients who are a potential source of infection should be dealt with separately

Standard Precautions: Key Components¹

Sharps:

- Safe passing of sharps during surgical procedures like tubal ligation
- Used needles must not be recapped
- Used needles must not be removed from disposable syringes
- Do not bend, break, or manipulate used needles by hand
- Place used sharps in specific puncture-resistant containers and transport in specified containers

Hand Hygiene

Handwashing: The purpose of handwashing is to mechanically remove soil and debris from the skin, and reduce the number of transient micro-organisms. Handwashing with plain soap and clean water is as effective as washing with antimicrobial soaps. In addition, plain soap causes less skin irritation.

Handwashing is different from surgical hand scrub and should be done before:

- Examining a client/patient
- Wearing gloves for any routine procedure/examination

Handwashing should be done after:

- Any situation in which hands may become contaminated, such as:
 - Handling soiled instruments and other items,
 - Touching mucous membranes, blood, or other body fluids (secretions or excretions), and
 - Having contact with a client.
 - Removing gloves

To encourage handwashing, programme managers should make every effort to provide soap and a continuous supply of clean water, either from the tap or a bucket, and single-use towels.

Antiseptic hand rub: It is done when simple handwashing is not possible or is difficult. Use of an antiseptic hand rub is more effective in killing transient and resident flora than handwashing with antimicrobial agents or plain soap and water. It is quick and convenient to perform, and gives a greater initial reduction in hand flora. Antiseptic hand rubs also contain a small amount of an emollient such as glycerin, propylene glycol, or sorbitol that protects and softens skin.

To be effective, an adequate amount of hand rub solution should be used. For example, by increasing the amount of hand rub from 1 ml to 5 ml per application (about 1 teaspoonful), the effectiveness increases significantly.

A non-irritating, antiseptic hand rub can be made by adding glycerin, propylene glycol, or sorbitol to alcohol (2 ml in 100 ml of 60-90 percent ethyl or isopropyl alcohol solution). Use 5 ml (about 1 teaspoonful) for each application and continue rubbing the solution over the hands until they are dry (15-30 seconds).

Surgical hand scrub: The purpose of the surgical hand scrub is to mechanically remove soil, debris, and transient organisms and to reduce resident flora during surgery. The goal is to prevent wound contamination by micro-organisms from the hands and arms of the surgeon and assistants.

For many years, preoperative hand scrubbing protocols required at least a 6- to 10-minute vigorous scrub with a brush or sponge, using soap containing an antiseptic agent (chlorhexidine or an iodophor). This practice, however, has been shown to damage the skin and can result in increased shedding of bacteria from the hands. Several studies suggest that neither a brush nor sponge is necessary to reduce bacterial counts on the hands of surgical staff to acceptable levels.

For example, a 2-minute handwashing with soap and clean water followed by application of 2-4 percent chlorhexidine or 7.5-10 percent povidone iodine was shown to be as effective as a 5-minute hand scrub with an antiseptic soap. As a result, the guidelines for performing the general surgical scrub technique have been made less harsh and take less time to perform.

Applying an antiseptic minimizes the number of micro-organisms on hands under the gloves and minimizes the growth of flora during surgery. This is important because gloves may have inapparent holes or tears, or may be nicked during surgery.

Alternatively, handwashing with plain soap and water followed by use of an antiseptic hand rub containing chlorhexidine has been shown to yield significantly greater reductions in microbial counts on hands, improve skin health, and reduce time and resources.

The steps for performing this simpler and shorter surgical hand scrub technique are:

- Step 1: Remove rings, watches, and bracelets.
- Step 2: Thoroughly wash hands, especially between fingers, and forearms to the elbows with soap and water.
- Step 3: Clean nails with a nail brush.
- Step 4: Rinse hands and forearms with water and dry thoroughly with a clean, dry towel or air dry.
- Step 5: Apply 5 ml (about 1 teaspoonful) of an antiseptic hand rub to hands and forearms and rub until dry, then repeat application and rubbing two more times for a total of at least 2 minutes, using a total of about 15 ml (3 teaspoonfuls) of the hand rub.

Step 6: Keep hands up and away from the body; do not touch any surface or article prior to putting sterile or high-level disinfected surgical gloves on both hands.

Gloves

Although the effectiveness of gloves in preventing contamination of health care providers' hands has been repeatedly confirmed, wearing gloves does not replace the need for handwashing. For example, even the best quality latex surgical gloves may have inapparent defects, gloves may be torn during use, and hands can become contaminated during glove removal. A separate pair of gloves must be used for each client to avoid cross-contamination.

Types of Gloves

There are three types of gloves used in health care facilities:

- Surgical gloves should be used when performing invasive medical or surgical procedures.
- Examination gloves provide protection to health care workers when they are performing many of their routine procedures.
- Utility or heavy-duty household gloves should be worn for processing instruments, equipment, and other items, for handling and disposing of contaminated waste, and when cleaning contaminated surfaces.

When surgical gloves are reused, they must be checked carefully for tears or cuts before final processing.

Table 4-1. Glove Requirements for Common Medical and Surgical Procedures¹

Task/Activity	Gloves Needed	Gloves Preferred	Gloves Acceptable
Blood pressure check	No	-----	-----
Temperature check	No	-----	-----
Injection	No	-----	-----
IV injection	No	-----	-----
Pelvic examination	Yes	Examination	HLD Surgical
IUCD insertion (loaded in sterile package and inserted using no-touch technique)	Yes	Examination	HLD Surgical
IUCD removal (using no-touch technique)	Yes	Examination	HLD Surgical
Norplant® implants insertion and removal	Yes	Sterile Surgical	HLD Surgical
Vasectomy or laparoscopy	Yes	Sterile Surgical	HLD Surgical

Handling and cleaning instruments	Yes	Utility/Examination	HLD Surgical
Handling contaminated waste	Yes	Utility/Examination	HLD Surgical
Cleaning blood or body fluid spills	Yes	Utility/Examination	HLD Surgical

Personal Protective Equipment and Drapes

Protective barriers, now commonly referred to as personal protective equipment (PPE), have been used for many years to protect clients from micro-organisms present on staff working in the health care setting. More recently, with the emergence of AIDS and HCV and the resurgence of tuberculosis and strains of influenza in many countries, use of PPE has become important for protecting the health care staff as well.

PPE includes gloves, masks/respirators, eyewear (face shields, goggles, or glasses), caps, gowns, aprons, and other items. In many countries, caps, masks, gowns, and drapes are made of cloth or paper. The most effective barriers, however, are made of treated fabrics or synthetic materials (e.g., plastic) that do not allow water or other liquids (blood or body fluids) to penetrate them. These fluid-resistant materials are not widely available because they are expensive. Lightweight cotton cloth (with a thread count of 140/inch²) is the material most commonly used for surgical clothing (masks, caps, and gowns) and drapes. Unfortunately, lightweight cotton does not provide an effective barrier because moisture can pass through it easily, allowing contamination. Denims, canvas, and heavy twill, on the other hand, are too dense for steam penetration (i.e., they cannot be sterilized), are hard to wash, and take too long to dry. When fabric is used, it should be white or light in color in order to show dirt and contamination easily.

Types of Personal Protective Equipment

Gloves protect hands from infectious materials and protect clients from micro-organisms on health care providers' hands. They are the most important physical barrier for preventing the spread of infection, but they must be changed between each client contact to avoid cross-contamination. For example, examination gloves should be worn when handling blood, body fluids, and surfaces or equipment contaminated with secretions or excretions and while touching non-intact skin or mucous membranes.

Masks should be large enough to cover the nose, lower face, jaw, and facial hair. They are worn in an attempt to contain the moisture droplets expelled when health care providers or surgical staff speak, cough, or sneeze, as well as prevent accidental splashes of blood or other contaminated body fluids from entering the health care provider's nose or mouth. Unless the masks are made of fluid-resistant materials, they are not effective in preventing either.

Eyewear protects health care providers in the event of an accidental splash of blood or other body fluid by covering the eyes. Eyewear includes clear plastic goggles, safety glasses, etc. Prescription glasses or glasses with plain lenses also are acceptable. Masks and eyewear should be worn when performing any task in which an accidental splash into the face is likely (e.g., performing a surgical procedure or cleaning instruments).

Caps are used to keep the hair and scalp covered so that flakes of skin and hair are not shed into the wound during surgery. Caps should be large enough to cover all hair. While caps provide protection to the client, their primary purpose is to protect the wearer from blood or body fluid splashes and sprays.

Scrub suits or cover gowns are worn over or instead of regular clothes. The main use of cover gowns is to protect the health care providers' clothing. Scrub suits usually consist of drawstring pants and a shirt. The neck of the shirt must not be cut so low as to slide off the wearer's shoulders. There is little evidence that scrub suits are needed during routine procedures when soiling of clothes is not likely.²

Surgical gowns were first used to protect clients from micro-organisms present on the abdomen and arms of health care providers during surgery. Surgical gowns made of fluid-resistant materials do play a role in keeping blood and other fluids, such as amniotic fluid, away from clients and health care workers, particularly in operating, delivery, and emergency rooms. Lightweight cotton gowns, which are available in most countries, offer little protection. Under these circumstances, if large spills occur, the best things to do is shower or bathe as soon as possible after completing the operation or procedure. If surgical gowns are worn, sleeves should either taper gently towards the wrists or end with elastic or ties around the wrists. (Large, droopy sleeves invite accidental contamination.)

In addition, the cuffs of the surgical gloves should completely cover the end of the sleeves.

Footwear is worn to protect feet from injury by sharps or fluids on the operating theatre floor. Theatre shoes/slippers must be kept clean and free of contamination from blood or other body fluid spills. All of the theatre shoes/ slippers must be washed daily with antiseptic solutions and must not be worn outside the theatre. Any shoe taken outside the operating theatre must not be taken to the theatre again unless it is thoroughly cleaned and washed with an antiseptic solution and dried properly.

Drapes are usually made of hemmed linen in squares of varying sizes. They are used to create an operative field around an incision, wrap instruments and items for sterilization, cover tables in the operating room, and keep clients warm during surgical procedures. The main types of drapes are:

- Towel drapes are used for drying hands, covering around the operative site, and

² Goldman DA. 1991. The role of barrier precautions in infection control. *Journal of Hospital Infection* 18(Suppl. A): 515–523.

wrapping small instruments. They are often made of heavier cotton cloth than other linen items, which makes them more water-resistant.

- **Drapes** or **lap sheets** are used for covering the client. They are large, usually made of lightweight cotton, and provide only limited protection to clients and health care providers.
- **Pack wrapper drapes** are large drapes that become a table cover when the sterile instrument pack is opened. This drape needs to be large enough only for wrapping the instruments and, when opened, to cover the tabletop completely.

Using Drapes for Surgical Procedures

Using sterile towel drapes to create a work area around the incision limits the amount of skin that needs to be cleaned and prepared with antiseptic solution prior to placing the drapes. Although this area is often called the sterile field, it is not completely sterile. Cloth drapes allow moisture to soak through them and can help spread organisms from skin, even after surgical cleansing with an antiseptic agent, into the incision. Thus, gloved hands (sterile or high-level disinfected), sterile or high-level disinfected instruments, and other items should not touch the towel drapes once they are in place. Because cloth drapes do not serve as an effective barrier, clean, dry towel drapes can be used if sterile towel drapes are not available.

The way in which the operative site is prepared and draped depends on the type of procedure to be performed. The following guidelines for draping are designed to reduce overuse of costly sterile items and avoid unnecessary draping:

- All drapes should be applied around a completely dry, widely prepared area.
- If sterile drapes are used, sterile or high-level disinfected surgical gloves should be worn when placing the drapes. (When putting drapes in place, health care workers must take care not to touch the client's body with gloved hands.)
- Drapes should be handled as little as possible and should never be shaken or flapped.
- Always hold drapes above the area to be draped and discard if they fall below this area.

Use of Antiseptic

Although antiseptics are sometimes used as disinfectants (e.g., Savlon or Dettol for processing instruments and other inanimate objects), they are not formulated for this use. They do not have the same killing power as chemical disinfectants (e.g., glutaraldehyde, hypochlorite, and peroxides) and should not be used for this purpose.

Plain soap is as effective as antimicrobial soap, provided the water is clean. Water that contains large amounts of particulate matter (makes the water cloudy) or is contaminated (high bacterial count) should not be used for performing a surgical hand scrub. In addition, antimicrobial soaps are costly and are more irritating to the skin than plain soap.

Skin Preparation prior to Surgical Procedures

Although skin cannot be sterilized, applying an antiseptic solution minimizes the number of micro-organisms around the surgical wound that may contaminate and cause infection.

Instructions:

- Step 1: Trim the hair close to the skin surface with scissors immediately before surgery. Do not shave hair around the operative site as it increases the risk of infection 5–10 fold because the tiny nicks in the skin provide an ideal setting for micro-organisms to grow and multiply.
- Step 2: Ask the client about allergic reactions (e.g., pyodine preparations) before selecting an antiseptic solution.
- Step 3: If the skin or external genital area is visibly soiled, gently wash it with soap and clean water and dry the area before applying the antiseptic.

Select the antiseptic solution from the following recommended products:

- Alcohol-based solutions (tinctures) of pyodine or chlorhexidine
 - Alcohols (60–90 percent ethyl, isopropyl, or methylated spirit)
 - Chlorhexidine gluconate (2–4 percent) (e.g., Hibitane, Hibiscrub, Hibiclens®)
 - Chlorhexidine gluconate and cetrimide, various concentrations (at least 2 percent) (e.g., Savlon)
 - Iodine (3 percent); aqueous iodine iodophors (7.5–10 percent), various other concentrations (e.g., Betadine), Chloroxylenol (Para-chloro-metaxylenol or PCMX 0.5–3.75 percent), various other concentrations (e.g., Dettol)
- Step 4: Using dry, high-level disinfected forceps and new cotton or gauze squares soaked in antiseptic, thoroughly cleanse the skin. Work from the operative site outward for several centimetres. (A circular motion from the centre out helps to prevent contamination of the operative site with local skin bacteria.)
- Step 5: Allow enough time for the antiseptic to be effective before beginning the procedure. For example, when an iodophor is used, allow 2 minutes or wait until the skin is visibly dry before proceeding, because the active agent is released slowly.

Note: Do not allow the antiseptic to pool underneath the client's body because it can irritate the skin.

Instructions for Cervical or Vaginal Preparation

For cervical and vaginal antiseptics, prior to inserting a uterine elevator for minilaparotomy or IUCD, select an aqueous (water-based) antiseptic such as an iodophor (povidone-iodine) or 2–4 percent chlorhexidine gluconate (e.g., Hibiclens or Savlon if properly prepared). Do not use alcohol or alcohol-containing preparations, such as Dettol. Alcohols cause burn and they also dry and irritate mucous membranes, which in turn promote the growth of microorganisms. In addition, hexachlorophene (pHisoHex[®]) is neurotoxic and should not be used on mucous membranes, such as the vaginal mucosa, because it is readily absorbed.

Skin Preparation for Injections

According to WHO (World Health Organization) and its Safe Injection Global Network (SIGN), swabbing of clean skin with an antiseptic solution prior to giving an injection is unnecessary, because in controlled trials no infections were noted. In addition, a review of microbiologic studies did not suggest that wiping the skin with an antiseptic, before giving an intradermal, subcutaneous, or intramuscular injection, reduces the risk of infection.

If the injection site is visibly soiled, wash the site with soap and water and dry with a clean towel, and then give the injection.

Safe Practices in Operating Rooms

In the past decade, awareness of the risk of exposure to blood and body fluids containing HIV, HBV, and most recently HCV has created a new era in surgical infection prevention practices. Just as clients must be protected from wound contamination and infections, the health care providers must also be protected from intra-operative injuries and exposure to clients' blood and other body fluids.

Preventing infections following an operation is a complex process that begins in the operating room by preparing and maintaining a safe environment for performing the surgery. Surgical aseptic techniques are designed to create such an environment by controlling the four main sources of infectious organisms: the client, health care providers, equipment, and operating room surroundings. Although the client is often the source of surgical infections, the other three sources are important and should not be overlooked.

Specific techniques required to establish and maintain surgical asepsis and make the surgical surroundings safer include the following:

- **Client considerations:** Skin cleaning pre-operatively, skin antiseptics, and wound covering.
- **Health care provider considerations:** Hand hygiene (handwashing and/or hand rub with waterless, alcohol-based antiseptic agents) or hand scrubbing; use and removal of gloves and gowns.

- **Equipment and room preparation considerations:** Traffic flow and activity patterns as well as housekeeping practices and decontamination, cleaning and either sterilization or high-level disinfection of instruments, gloves, and other items.
- **Surrounding considerations:** Maintaining an aseptic operating field and using safer operating practices and techniques.

Instruments Causing Injuries

The vast majority of sharps injuries in hospitals occur in the operating room and most are due to scalpel and suture needles being most frequently used during operations. Many other items can also cause sharps injuries and glove tears resulting in exposure to blood. Some of the most important items that are used in an FP clinic and can cause injury are:

- Skin hooks and towel clips
- Sharp-pointed scissors and sharp-tipped mosquito forceps and dissecting forceps used in no-scalpel vasectomy (NSV)
- Sharp-toothed tenaculi
- Scalpel blades
- Hypodermic needles
- Suture needles
- Laparoscopy and implant trocars

Almost all of these injuries can be easily avoided with no extra expenditure. For example:

- Use a small Mayo forceps (not fingers) when holding the scalpel blade, putting it on or taking it off, or loading the suture needle. (Alternatively, use disposable scalpels with a permanent blade that cannot be removed.)
- Always use tissue forceps, not fingers, to hold tissue when using a scalpel or suturing.
- Use a hands-free technique to pass or transfer sharps (scalpel, needles, and sharp-tipped scissors) by establishing a Safe or Neutral Zone in the operative field.
- Always remove sharps from the field immediately after use.
- Make sure that sharps containers are replaced when they are only three-quarters full and place containers as close to and convenient for the health care provider as possible (i.e., within arm's reach).

A safer method of passing sharps (scalpels, suture needles, and sharp scissors) during surgery, called the hands-free technique, has recently been recommended. This technique for sharps is inexpensive, simple to use, and ensures that the surgeon, assistant, or scrub assistant never touches the same instrument at the same time.

Instruments passed with the hands-free technique (besides those listed above) include anything sharp enough to puncture a glove (e.g., trocars, sharp-tipped mosquito forceps, and loaded needle holders). Using the hands-free technique, the assistant places a sterile or high-level disinfected kidney tray/basin, or other suitable small container, on the operative field between the assistant and the surgeon. The container is designated as the

Safe or Neutral Zone in which sharps are placed before and immediately after use.

Another way to do this is to have the assistant place the instrument in a container and pass it to the surgeon. The surgeon lifts the instrument out of the container, which is left on the operative site until the surgeon returns the instrument to it.

The assistant then picks up the container and returns it to the Mayo stand.

Table 4-2. Reducing the Risk of Exposure

Function	Safer	Less Safe	Least Safe!
Skin incision	Cautery	Disposable scalpel	Scalpel with removable blade
Cutting	Scissors, blunt tip or cautery probe	Scissors, sharp tip	Scalpel
Haemostasis	Blunt suture needles, staples, or cautery	Sharp suture needles	Wire sutures
Sponging with gauze while using a scalpel	Surgeon does sponging; assistant only retracts	Assistant sponges only on request	Assistant sponges spontaneously (no communication)
Retraction	Blunt retractor	Sharp retractor	Fingers or hands
Sharps transfer	Neutral Zone	Hand-to-hand (communication)	Hand-to-hand (no communication)
Surgical gloves	Double-gloving	Single pair of gloves or double-gloving with reprocessed gloves	Single pair of reprocessed gloves
Closing peritoneum (small, 2-3 cm incision)	Do not close	Purse-string closure using tissue forceps to grasp needle	Purse-string closure using fingers to grasp needle

Safe Handling of Hypodermic Needles and Syringes

In the operating room, scalpels and suture needles are the leading source of penetrating injuries. Hypodermic (hollow-bore) needles cause the most injuries to health care providers at all levels. Consider:

- Surgeons and assistants are most often stuck by hypodermic needles during procedures.
- Cleaning staff are most often stuck by needles when washing soiled instruments.
- Housekeeping staff are most often stuck by needles when disposing of infectious waste material.

Safety Tips for Using Hypodermic Needles and Syringes

- Use needle and syringe only once.
- Do not disassemble the needle and syringe after use.

- Do not recap, bend, or break needles prior to disposal.
- Decontaminate the needle and syringe prior to disposal.
- Dispose of the needle and syringe in a puncture-resistant container.

If the needle has to be recapped, use the one-handed recap method:

- First, place the needle cap on a firm, flat surface; then remove your hand.
- Next, with one hand holding the syringe, use the needle to “scoop” up the cap.
- With the cap now covering the needle tip, turn the syringe upright (vertical) so that the needle and syringe are pointing towards the ceiling.
- Finally, using the forefinger and thumb of your other hand, grasp the cap just above its open end and push the cap firmly down onto the hub (the place where the needle joins the syringe under the cap).

Figure 4-1. One-Handed Recap Method

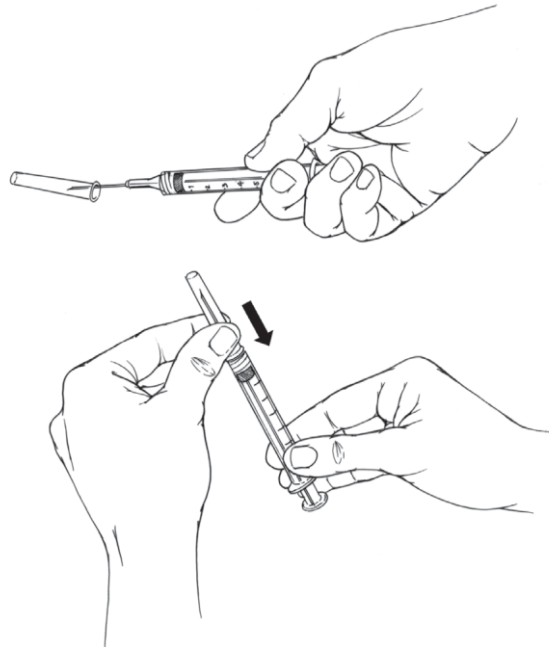

Source: Tietjen L, Bossemeyer D, and McIntosh N. 2003. Infection Prevention Guidelines for Healthcare Facilities with Limited Resources. Jhpiego: Baltimore, Maryland.

Sharps Containers

Using sharps disposal containers helps prevent injuries from sharps. Sharps containers should be fitted with a cover, and should be puncture-proof, leak-proof, and tamper-proof (difficult to open or break). If plastic or metal containers are unavailable, use containers made of dense cardboard (cardboard safety boxes) that meet WHO specifications. If cardboard safety boxes are unavailable, easily available objects can substitute as sharps containers:

- Tin with a lid
- Thick plastic bottle
- Heavy plastic box
- Heavy cardboard box

Recommendations for Safe Use of Sharps Containers

- All sharps containers should be clearly marked "SHARPS" and have pictorial instructions for their use and disposal.
- Place sharps containers away from high-traffic areas and as close as possible to where the sharps will be used. Do not place containers near electric switches, overhead fans, or thermostat controls where people might accidentally put one of their hands into them.
- Attach containers to walls or other surfaces if possible. Position the containers at a convenient height so staff can use and replace them easily.
- Never reuse or recycle sharps containers.
- Mark the containers clearly so that people will not unknowingly use them as garbage receptacles.
- Do not fill the safety box beyond three-quarters of its capacity.
- Avoid shaking a container to settle its contents to make room for more sharps.

Infection Prevention Techniques

Asepsis and aseptic techniques are general terms used to describe the combination of efforts made to prevent entry of micro-organisms into any area of the body where they are likely to cause infection. The goal of asepsis is to eliminate or reduce to a safe level the number of micro-organisms on both animate (living) surfaces such as skin and other body tissues, and inanimate objects (e.g., surgical instruments).

Antisepsis is the prevention of infection by killing or inhibiting the growth of micro-organisms on skin and other body tissues.

Instrument Processing

Steps for infection prevention techniques are necessary for all surgical procedures, including FP and maternal and child health care. The steps are:

Decontamination

Decontamination is the first step in handling large surfaces (e.g., examination or operating tables), surgical instruments, and linen and gloves contaminated with blood or body fluids during or following surgical procedures. This step, taken before cleaning, makes the handling of these contaminated objects safer for the health care providers, especially cleaning personnel, and it reduces the risk of transmitting infections.

Chlorine Solutions for Decontamination and High-Level Disinfection

WHO recommends 0.5 percent chlorine solution for decontaminating surfaces and instruments before cleaning. The solution is fast-acting, very effective against hepatitis and HIV viruses, inexpensive, and readily available as common bleaching agents (sodium hypochlorite solutions). It is extremely useful for decontaminating large surfaces such as examination tables. These surfaces should be wiped with 0.5 percent chlorine solution, and rinsed with water and dried to prevent corrosion.

To decontaminate examination/operating table tops, wipe the surface with 0.5 percent chlorine solution. For articles such as linen, gloves, and instruments, soak them in 0.5 percent chlorine solution for 10 minutes. This solution can be prepared from household liquid bleach or powder available in different concentrations.

Chlorine solution is also effective in high-level disinfection of instruments. A major disadvantage is corrosion of metals if instruments are left too long in the solution. Using a plastic container, however, you can safely soak stainless steel instruments in 0.1 percent chlorine solution for up to 20 minutes for high level- disinfection. Afterwards, rinse them with boiled water and dry them promptly to prevent corrosion. The solution deteriorates rapidly; hence, use a fresh one daily and also whenever the solution becomes visibly cloudy.

Preparation of Chlorine Solution

Precautions

- Turn off the fan.
- Wear gloves, cap, mask, and eye glasses to avoid splashing in eyes and preventing irritating effects.
- Always use plastic containers and spoons.
- Make fresh solution, every day; discard the solution if it becomes cloudy.
- Do not expose the solution to direct sunlight.

Method of Preparation

Formula for preparing 0.5 percent chlorine solution:

- Bleaching powder:
 - Grams per litre = % of dilution required / % of concentration of powder x 1000
- Liquid bleach:

- Parts of water = % of concentrate given on container (liquid bleach) / % of dilution required - 1

Steps of Preparation

- Calculate the amount of water and bleach.
- Put the calculated parts of clean tap water in a plastic container.
- Add calculated parts of liquid bleach/powder (when preparing with powder, add small amount of water to make the paste and then add the rest of the water).
- Stir well.

Cleaning

Cleaning is the process that physically removes all visible blood, body fluids, or any other foreign material such as dust or soil from the inanimate objects. It improves the quality of subsequent high-level disinfection or sterilization.

To clean examination/operating table tops, linen, gloves, and storage containers, wash organic material that remains after decontamination with detergent and water. Then wipe the table top and rinse other items with clean water. For cleaning instruments, use a brush to remove all particles.

Sterilization

Sterilization is the process that eliminates all micro-organisms, including bacterial endospores, from inanimate objects. Some of the sterilization techniques are mentioned below.

Sterilization through Autoclaving

For this purpose, temperatures of 121°C and 15 pounds pressure (pounds per square inch) are required for 20 or 30 minutes (when unwrapped or wrapped respectively), depending upon the article to be sterilized. These temperatures are achieved by the use of an autoclave in which steam generated drives out the air, increases the pressure, and raises the temperature to the required level.

Remember to properly load the autoclave with appropriately wrapped and positioned instruments and other equipment; otherwise, sterilization will be inadequate. Also, insert a sterilization indicator tape to ensure that all objects are exposed to the hot steam.

Sterilization of many instruments, such as those with cutting edges and glass syringes, is better performed with dry heat. Temperatures of 170°C are required for 20 or 30 minutes (when unwrapped or wrapped respectively). To ensure even heating, an electric oven fitted with a fan is necessary.

Chemical Sterilization

Chemical sterilization achieves disinfection by using liquid chemicals and is recommended for equipment and items that cannot be autoclaved. Chemicals destroy or inhibit the growth of bacteria and other micro-organisms similar to heating, i.e., by protein coagulation or enzyme inhibition. The objects that are easiest to sterilize chemically are those with a smooth, flat, and firm surface such as a laparoscopic instrument.

Items are sterilized by soaking them in a particular chemical solution (such as the one containing glutaraldehyde), followed by rinsing them in sterile/boiled water.

Cidex, which contains glutaraldehyde, is a commonly available solution used for sterilization. Other products containing glutaraldehyde or other chemical sterilizers may be locally available, but make sure that the solution to be used is appropriate for sterilization.

Remember that:

- Glutaraldehyde is irritating to the skin, eyes, and respiratory tract. While using it, wear gloves, limit exposure time, and keep the area well ventilated.
- The length of time that glutaraldehyde solutions can be used varies, usually from 14-30 days. Always follow the manufacturer's instructions regarding proper storage temperatures and expiry date. Solutions should be replaced any time they become cloudy.

Formaldehyde is potentially cancer-causing and extremely irritating to the skin, eyes, nose, and respiratory tract. Therefore, routine use of formaldehyde for sterilizing instruments and other items is not recommended.

Instructions for chemical sterilization:

- Choose the appropriate disinfectant.
- Follow directions for proper dilution of the chemical.
- Soak items in the solution for the required period of time.
- Completely immerse clean items in disinfectant.
- Rinse items thoroughly with sterile or boiled water or sterilized normal saline.
- If needed, dry the items with a sterile towel, or let them air dry.
- Use the sterile items immediately, or store them in a suitable, tightly closed sterile container for up to 1 week.

High-Level Disinfection

High-level disinfection (HLD), through boiling or the use of chemicals, eliminates all micro-organisms, viruses, bacteria, parasites, and fungi, with the exception of some bacterial endospores such as tetanus and gangrene. HLD for instruments that perforate skin and mucous membranes is acceptable only when autoclaving is not possible and all earlier stages of processing are observed.

High-Level Disinfection by Boiling

- Use a container with a lid for boiling instruments.
- Make sure that the items being processed for HLD are completely immersed in water.
- Boil all instruments for 20 minutes, calculating the time after the boiling point is reached.
- Do not add to or remove anything from the pot/container after water begins to boil.
- Air dry before use or storage.

High-Level Disinfection by Chemicals

Where boiling is not possible, HLD can also be done by using chemicals like glutaraldehyde or 0.1 percent chlorine solution.

When using a glutaraldehyde solution:

- Prepare it according to the instructions.
- If possible, use an indicator strip each time to determine if the solution is still effective.
- After preparing the solution, put it in a clean container with a lid.
- Mark the container with the date the solution was prepared and the date it expires.

When using a chlorine solution:

- Prepare the 0.5 percent chlorine solution as described for decontamination using boiled water. Fresh solution should be made each day or more often if the solution becomes cloudy.
- Items must be completely immersed in solution. Open all hinged instruments and disassemble items with sliding or multiple parts.
- Soak for 10 minutes.
- Prepare 0.1 percent chlorine solution.
- Immerse the items for 20 minutes.
- Rinse items thoroughly with boiled water.

Table 4-3. Infection Prevention in Processing Instruments and Equipment

Process	It is the first step in handling dirty instruments; reduces risk of hepatitis B, C, and HIV	Decontamination	Cleaning	High-Level Disinfection	Sterilization ¹
Instruments/Equipment Pelvic exam table top or other large surface area	Wipe off with 0.5% chlorine	Wash with detergent and water if organic material remains after decontamination procedure	Not necessary	Not necessary	Not necessary
Linens (caps, gowns, masks, and surgical drapes)	<ul style="list-style-type: none"> Soak in 0.5% chlorine solution for 10 minutes if contaminated with blood or body fluids prior to cleaning Rinse and wash immediately² 	<ul style="list-style-type: none"> Wash with detergent and water, removing all particles Rinse with clean water Air dry 	<ul style="list-style-type: none"> Boil or chemically HLD Air-dried surgical drapes should be ironed before use 	<ul style="list-style-type: none"> Autoclave at 121°C (250°F) and 106 kPa (15 lbs/in²) for 20 minutes 	<ul style="list-style-type: none"> Not necessary for caps, gowns, and masks. For surgical drapes: <ul style="list-style-type: none"> Autoclave at 121°C (250°F) and 106 kPa (15 lbs/in²) for 20 minutes
Gloves (rubber or plastic)	<ul style="list-style-type: none"> Soak in 0.5% chlorine solution for 10 minutes prior to cleaning Rinse or wash immediately² 	<ul style="list-style-type: none"> Wash with detergent and water, removing all particles Rinse with clean water and check for holes Air dry 	<ul style="list-style-type: none"> If touching only mucous membranes or broken skin (e.g., for pelvic exam or IUCD insertion): <ul style="list-style-type: none"> Boil for 20 minutes in a container with a lid (start timing when water begins to boil) Gloves must be immersed completely in water Do not add anything to container after water begins to boil Air dry before use or storage 	<ul style="list-style-type: none"> Autoclave at 121°C (250°F) and 106 kPa (15 lbs/in²) for 20 minutes 	<ul style="list-style-type: none"> If used for surgery: <ul style="list-style-type: none"> Autoclave at 121°C (250°F) and 106 kPa (15 lbs/in²) for 20 minutes

Instruments/Equipment	Decontamination	Cleaning	High-Level Disinfection	Sterilization
Instruments for pelvic examination and IUCD insertion (e.g., specula, tenacula, forceps, and uterine sounds)	<ul style="list-style-type: none"> • Soak in 0.5% chlorine solution for 10 minutes • Rinse or wash immediately² 	<ul style="list-style-type: none"> • Using a brush, wash with detergent and water, removing all particles • Rinse with clean water • Air dry 	<p>Boiling:</p> <ul style="list-style-type: none"> • Boil for 20 minutes in a container with a lid (start timing when water begins to boil) • Instruments must be immersed completely in water during boiling • Do not add anything to container after water begins to boil • Air dry before use or storage <p>Chemical: Soak for 20 minutes in:</p> <ul style="list-style-type: none"> • A glutaraldehyde and rinse well in water that has been boiled for 20 minutes 	<ul style="list-style-type: none"> • Dry heat for 1 hour after reaching 170°C (340°F) or • Autoclave at 121°C (250°F) and 106 kPa (15 lbs./in²) for 20 minutes (30 minutes if wrapped)
Instruments for voluntary sterilization and Norplant insertion	<ul style="list-style-type: none"> • Soak in 0.5% chlorine solution for 10 minutes prior to cleaning (Rinse or wash immediately²) 	<ul style="list-style-type: none"> • Using a brush, wash with detergent and water removing all particles • Rinse with clean water, air or towel dry 	<p>Acceptable:³</p> <ul style="list-style-type: none"> • Boil or do chemical HLD as above 	<ul style="list-style-type: none"> • Dry heat for 1 hour after 170°C (340°F)
Needles and syringes	<ul style="list-style-type: none"> • Fill assembled needle and syringe with 0.5% chlorine solution • Soak for 10 minutes prior to cleaning • Rinse by flushing three times with clean water 	<ul style="list-style-type: none"> • Disassemble, then wash with detergent and water, removing all particles • Rinse with clean water • Air dry 	<p>Acceptable:³</p> <ul style="list-style-type: none"> • Boil or do chemical HLD as above <p>Place items that float in a weighted, processed bag</p>	<ul style="list-style-type: none"> • Dry heat for 1 hour after 170°C (340°F), or • Autoclave at 121°C (250°F) and 106 kPa (15 lbs./in²) for 20 minutes (30 minutes if wrapped)

Instruments/Equipment	Decontamination	Cleaning	High-Level Disinfection	Sterilization
Storage containers for instruments	<ul style="list-style-type: none"> Soak in 0.5% chlorine solution for 10 minutes prior to cleaning Rinse or wash immediately² 	<ul style="list-style-type: none"> Wash with detergent and water, removing all particles Rinse with clean water Air dry 	<p>Boil container and lid as above; if container is too large, then:</p> <ul style="list-style-type: none"> Fill container with 0.1% chlorine solution and soak for 20 minutes Rinse with water that has been boiled for 20 minutes and air dry before use <p>Disinfect weekly, and when empty or contaminated</p>	<ul style="list-style-type: none"> Dry heat for 1 hour after reaching 170°C (340°F) or Autoclave at 121°C (250°F) and 106 kPa (lbs./in²) for 20 minutes (30 minutes if wrapped) <p>Disinfect weekly, and when empty or contaminated</p>
Endoscopes (laparoscopes)	<ul style="list-style-type: none"> Wipe exposed surfaces with gauze pad soaked with 60-90% alcohol Rinse immediately 	<ul style="list-style-type: none"> Disassemble, then wash with detergent and water, removing all particles Rinse with clean water Air dry 	<p>Soak for 20 minutes in:</p> <ul style="list-style-type: none"> Glutaraldehyde solution Rinse in water that has been boiled for 20 minutes 	<p>Sterilize daily if possible, using chemical sterilization. Soak in:</p> <ul style="list-style-type: none"> Glutaraldehyde for 10 hours Rinse with sterilized water or water that has been boiled for 20 minutes

¹ If unwrapped, use immediately; if wrapped, may be stored up to 1 week prior to use.

² Avoid prolonged exposure to chlorine solution to minimize corrosion of instruments and deterioration of rubber or cloth products.

³ If sterilization (dry heat or autoclave) not available, these items can be HLD either by boiling or soaking in chemical disinfectant.

⁴ Instruments with cutting edges or needles should not be sterilized at temperature above 160°C to avoid dulling.

Adapted from: Perkins JJ. 1983. Principles and Methods of Sterilization in Health Sciences, 2nd ed. Charles C. Thomas Publisher Ltd.: Springfield, Illinois.

Waste Management

Wastes from hospitals and health care facilities may be contaminated (potentially infectious) or non-contaminated.

Contaminated wastes include blood, pus, urine, stool, and other body fluids, as well as items that come in contact with them, such as used dressings. Wastes from operating rooms (human tissue, blood or blood soaked sponges, gauze, or cotton) and laboratories (blood, faeces, sputum, urine specimens, and microbiological cultures) should be considered contaminated. Soiled medical devices or items that can inflict injury (e.g., used needles and scalpel blades) are capable of spreading blood-borne diseases such as hepatitis B, hepatitis C, and AIDS and are also considered contaminated waste.

The purpose of waste management is to:

- Protect people who handle waste items from accidental injury.
- Prevent the spread of infection to health care providers who handle the waste.
- Prevent the spread of infection to the local community.

Open piles of waste should be avoided because they:

- Are risks to those who scavenge and unknowingly reuse contaminated items.
- Allow persons to accidentally step on sharp items and injure themselves.
- Produce foul odours.
- Attract insects and animals.

Proper disposal of contaminated waste may include:

- Pouring liquids or wet waste directly into a safe sewerage system.
- Incinerating (burning) items to destroy the item as well as any micro-organisms. (This is the best method for disposal of contaminated waste. Burning also reduces the bulk volume of waste and ensures that the items are not scavenged and reused.)
- Burying all contaminated wastes to prevent further handling.

Handling of Contaminated Waste

Proper handling of contaminated waste minimizes the spread of infection to health care personnel and to the local community. Whenever possible, contaminated waste should be collected and transported to disposal sites in leak-proof, covered waste containers.

- Use plastic or galvanized metal containers with tight-fitting covers for contaminated wastes. Many facilities now use colour-coded plastic bags to alert handlers to the contents and to keep the general (non-contaminated) waste separate from contaminated waste.
- Use puncture-resistant sharps containers for all disposable sharps (sharps that will not be reused).
- Place waste containers close to where the waste is generated and where convenient for users (carrying waste from place to place increases the risk of infection for handlers).

This is especially important for sharps, which carry the highest risk of injury for health care providers.

- Equipment that is used to hold and transport wastes must not be used for any other purpose in the clinic or hospital. (Contaminated waste containers should be marked.)
- Wash all waste containers with a disinfectant cleaning solution (0.5 percent chlorine solution plus soap) and rinse with water regularly.
- When possible, use separate containers for combustible and non-combustible wastes prior to disposal. This step prevents workers from having to handle and separate wastes by hand later.
- Use PPE when handling wastes (e.g., heavy-duty utility gloves and closed protective shoes).
- Wash hands or use a waterless, alcohol-based antiseptic hand rub after removing gloves when handling wastes.

Disposal of Sharps

Disposal of sharp items (hypodermic needles, suture needles, razors, and scalpel blades) require special handling because they are the items most likely to injure health care providers who handle them as well as people in the community if these items go to the municipal landfill.

Encapsulation: Encapsulation is recommended as the easiest way to safely dispose of sharps. Sharps are collected in puncture-resistant and leak-proof containers. When the container is three-quarters full, a material such as cement (mortar), plastic foam, or clay is poured into the container until it is completely filled. After the material has hardened, the container is sealed and may be land-filled, stored, or buried. It is also possible to encapsulate chemical or pharmaceutical waste together with sharps.³

Steps for the Disposal of Sharps

- Step 1: Do not recap needle or disassemble needle and syringe.
- Step 2: After use, hold the needle tip under the surface of a 0.5 percent chlorine solution, fill the syringe with solution, and push out (flush) three times.
- Step 3: Place assembled needles and syringes to be disposed of in a puncture-resistant sharps container such as a heavy cardboard box, plastic bottle, or tin can with lid. The opening in the lid should be large enough so that items can be easily dropped through it, but small enough that nothing can be removed from inside. (Old intravenous fluid bottles may also be used, but they can break.)
- Step 4: When the container is three-quarters full, it should be removed from the procedure area for disposal.

Disposing of the Sharps Container

- Step 1: Wear heavy-duty utility gloves.
- Step 2: When the sharps container is three-quarters full it should be capped, plugged, or taped tightly closed. Be sure that no sharp items are sticking out of the container.
- Step 3: Dispose of the sharps container by burning, encapsulating, or burying. Step 4: Remove utility gloves (wash daily or when visibly soiled, and dry).
- Step 5: Wash hands and dry them with a clean cloth or towel or air dry. (Alternatively, if hands are not visibly soiled, apply 5 ml, about 1 teaspoonful, of an antiseptic hand rub and rub the solution vigorously onto hands until dry.)

How to Dispose of Solid Contaminated Waste

Solid contaminated waste (e.g., surgical specimens, used dressings, and other items contaminated with blood and organic materials) may carry micro-organisms.

- Step 1: Wear heavy-duty or utility gloves when handling and transporting solid wastes.
- Step 2: Dispose of solid wastes by placing them in a plastic or galvanized metal container with a tight-fitting cover.
- Step 3: Collect the waste containers on a regular basis and transport the burnable ones to the incinerator or another area for burning.
- Step 4: Remove utility gloves (wash daily or when visibly soiled and dry).
- Step 5: Wash and dry hands or use an antiseptic hand rub as described above.

Incineration

Types of Incinerators

Incineration is a high-temperature process that reduces the volume and weight of waste. This process is usually selected to treat waste that cannot be recycled, reused, or disposed of in a sanitary landfill or dumpsite.

Incinerators can range from extremely sophisticated, high-temperature ones to very basic units that operate at much lower temperatures. All types of incinerators, if operated properly, eliminate micro-organisms from waste and reduce it to ashes.

Four basic types of incinerators are used for treating waste:

1. Double-chamber, high-temperature incinerators are designed to burn infectious waste.
2. Single-chamber, high-temperature incinerators are less expensive and are used when double-chamber incinerators are not affordable.
3. Rotary kilns operate at high temperatures and are used for destroying cytotoxic substances and heat-resistant chemicals.
4. Drum or brick (clay) incinerators operate at lower temperatures and are less effective, but can be made locally using readily available materials.

Open burning is not recommended because it is dangerous, unsightly, and the wind will scatter the waste.

For health care facilities with limited resources and where high-temperature incinerators are not affordable, waste may be incinerated in a drum incinerator. A drum incinerator is the simplest form of single-chamber incinerator. It can be made inexpensively and is better than open burning.

How to Build and Use a Simple Drum Incinerator for Waste Disposal

- Step 1: Where possible, select a site downwind from the clinic.
- Step 2: Build a simple incinerator using local materials (mud or stone) or a used oil drum (e.g., a 55-gallon drum). The size depends on the amount of daily waste collected.
- Step 3: Make sure the incinerator has:
- Sufficient air inlets underneath for good combustion.
 - Loosely placed fire bars to allow for expansion.
 - An adequate opening for adding fresh refuse and removing ashes.
 - A long enough chimney to allow for a good draught and evacuation of smoke.
- Step 4: Place the drum on hardened earth or a concrete base.
- Step 5: Burn all combustible waste, such as paper and cardboard, as well as used dressings and other contaminated wastes. If the waste or refuse is wet, add kerosene so that a hot fire burns all of the waste. Ash from incinerated material can be treated as non-contaminated waste.

Figure 4-2. Design for a Simple Oil Drum Incinerator

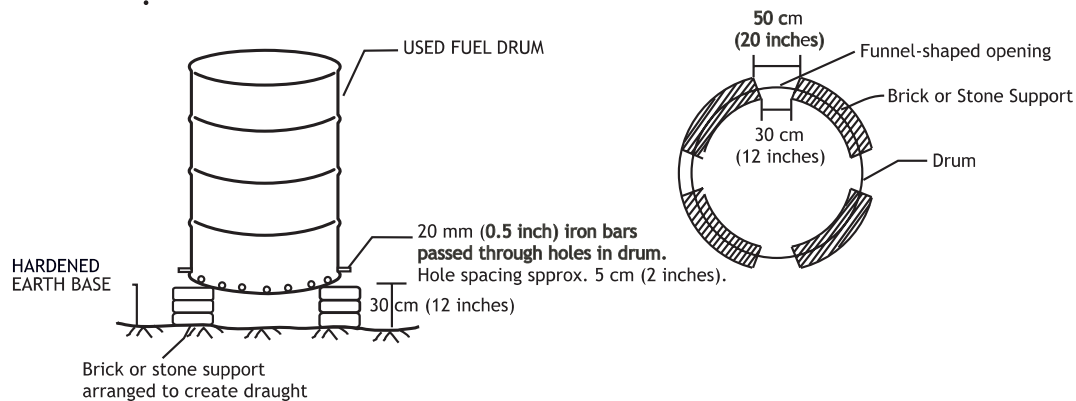

How to Make and Use a Small Burial Site for Waste Disposal

- Step 1: Find an appropriate location.
- Step 2: Dig a pit 1 metre (3 feet) square and 2 metres (6 feet) deep. The bottom of the pit should be 2 metres (6 feet) above the water table.
- Step 3: Dispose of the contaminated waste in the pit and cover the waste with 10–15 cm (4–6 inches) of dirt each day. The final layer of dirt should be 50–60 cm (20–24 inches) and compacted to prevent odours and attraction of insects, and to keep animals from digging up the buried waste. Depending on the volume of waste, the capacity of the pit should last for 30–60 days.

5

MEDICAL ELIGIBILITY CRITERIA

Introduction

Over the past 30 years, there have been significant advances in the development of new contraceptive technologies, including transitions from high-dose to low-dose combined oral contraceptives and from inert to copper- and levonorgestrel-releasing IUCDs. In addition, combined injectable contraceptives, a combined hormonal patch and vaginal ring, progestin-only injectables, and implants have been introduced.

This chapter is intended to update the medical eligibility criteria (MEC) used in the provision of fertility awareness methods, lactational amenorrhoea methods, barrier methods, all hormonal methods, IUCDs, male and female sterilization, and emergency contraception.

Barriers to contraceptive Use

In recent years, attention has been focused on minimizing administrative barriers to FP, that is, unnecessary rules and regulations that burden clients and narrow their contraceptive choices. One type of administrative barrier, so-called medical barriers, has a medical rationale even though it is scientifically unjustified.¹ These barriers include:

- Outdated contraindications that remain part of a programme's official guidelines or providers' informal screening routine, for example, refusing to supply oral contraceptives to women with varicose veins or tuberculosis.
- Eligibility requirements that needlessly limit the use of certain methods based on a woman's age, parity, or lack of spousal consent.
- Demands for additional procedures that may benefit women's overall health but are unnecessary for safe and effective contraceptive use, for example, requiring women to undergo a pelvic examination before receiving oral contraceptives.

¹Bertrand JT et al. 1995. Access, quality of care, and medical barriers in family planning programs. *International Family Planning Perspectives* 21(2): 64–69, 74; Shelton J, Angle MA, and Jacobstein RA. 2001. Medical barriers to access to family planning. *Lancet* 340: 1334–1335; Stanback J et al. 1997. Menstruation requirements: A significant barrier to contraceptive access in developing countries. *Studies in Family Planning* 28(3): 245–250.

- Creating hurdles for women by making extra visits mandatory.
- Requiring certain provider qualifications to deliver a method, for example, restricting IUCD insertions to physicians when nurses can be trained to perform the task.
- Provider biases for or against specific methods.
- Regulatory mechanisms that prevent certain contraceptive methods from being approved or that hinder their advertising.

What are Unjustified Medical barriers?

- Practices derived (at least partly) from a medical rationale.
- Non-evidence-based barriers that result in denial of contraception.
- Eligibility restrictions, based on providers' limitations/personal biases.

Examples of Unjustified Medical barriers

- Unnecessary barriers to initiation: menstruation
- Other client eligibility criteria: age, parity, marital status
- Inappropriate follow-up schedule: IUCD follow-up every 6 months
- Rest periods required: every 2-3 years for pills
- Unnecessary procedures required: pelvic exam, pregnancy test
- Provider bias: DMPA better for thin women

Addressing Medical barriers: World Health Organization(WHO) Medical eligibility criteria

What are the Medical eligibility criteria?

- Recommendations on the specific conditions (medical and non-medical) to safely use contraceptive methods for:
 - Initiation; and
 - Continuation.

These recommendations are based on evidence that depends on:

- Direct studies on users with and without the conditions;
- Theoretical considerations; and
- Expert opinions.

Identification of conditions

- Conditions represent either:

An individual's characteristics (e.g., age, parity, etc.);

- Known pre-existing medical conditions (e.g., hypertension, etc.); and

²Miller K et al. 1998. Clinic-Based Family Planning and Reproductive Health Services in Africa: Findings from Situation Analysis Studies. Population Council: New York; Speizer IS et al. 2000. Do service providers in Tanzania unnecessarily restrict clients' access to contraceptive methods? International Family Planning Perspectives 26(1): 13–20, 42; Stanback J and Twum-Baah KA. 2001. Why do family planning providers restrict access to services? An examination in Ghana. International Family Planning Perspectives 27: 37–41.

- Use of medications (e.g., rifampicin).

Table 5.1 - 5.4 on the following pages summarizes the World Health Organization (WHO) Medical Eligibility Criteria for starting contraceptive methods.

Table 5-1. World Health Organization Categories for Temporary Methods³

WHO category	eligibility criteria
1	can use the method. No restriction on use. all trained service providers can give.
2	can use the method. advantages generally outweigh theoretical or proven risks. category 2 conditions could be considered in choosing a method. if the client chooses the method, more than usual follow-up may be needed.
3	Use of method not usually recommended unless other more appropriate methods are not available or not acceptable. Should only use the method if according to clinical judgement the risk of pregnancy is greater than the use of contraceptive. careful follow-up will be needed.
4	Should not use the method. condition represents an unacceptable health risk if the method is used.

Simplified two-category System

In case of limited clinical judgement, the WHO four-category classification system can be simplified into a two-category system as shown in this table:

Table 5-2. Simplified Medical Eligibility Criteria Classification Categories³

category	With clinical Judgement	With limited clinical Judgement
1	Use method in any circumstances.	yes (Use Method)
2	generally use method.	
3	Use of method not usually recommended unless other more appropriate methods are not available or not acceptable.	
4	Method not to be used.	

³Adapted from: World Health Organization Department of Reproductive Health and Research (WHO/RHR) and Johns Hopkins Bloomberg School of Public Health/Center for Communication Programs (CCP), INFO Project. 2007. Family Planning: A Global Handbook for Providers. CCP and WHO: Baltimore and Geneva; WHO/RHR and CCP, INFO Project. 2008. Appendix D. Medical Eligibility Criteria. (Appendix from Family Planning: A Global Handbook for Providers.) At: <http://info.k4health.org/globalhandbook/remindersheets/Word-AppendixD.doc>.

Table 5-3. World Health Organization Categories for Female Sterilization and Vasectomy³

category	Rationale
accept (a)	No medical reason prevents performing the procedure in a routine setting.
caution (c)	the procedure can be performed in a routine setting but with extra preparation and precautions.
delay (d)	delay the procedure. condition must be treated and resolved before the procedure can be performed. Provide temporary methods.
Special (S)	refer client to a centre where an experienced surgeon and staff can perform the procedure. Setting should be equipped for general anaesthesia and other medical support. Provide temporary methods.

Note: in the table that follows, category 3 and 4 conditions are shaded to indicate that the method should not be provided where clinical judgement is limited.

WHO Medical Eligibility Criteria Updates 2015

During 9–12 March 2014 and 24–25 September 2014, the World Health Organization (WHO) convened two meetings of a Guideline Development Group (GDG), consisting of 68 individuals representing a wide range of stakeholders for the purpose of reviewing and, where appropriate, revising its Medical eligibility criteria for contraceptive use, fourth edition (MEC) guidance. Fourteen topics (encompassing over 575 recommendations) were reviewed by the GDG as part of the revision. All other existing recommendations within the fourth edition were confirmed by the GDG and did not undergo formal review for the updated fifth edition of the MEC.

Recommendations are provided for:

- Combined hormonal contraceptive use (CHC) by age group .
- CHC use among breastfeeding women ?
- CHC use among postpartum women?
- CHC use among women with superficial venous disorders .
- CHC use among women with known dyslipidaemias without other known cardiovascular risk factors .
- Progestogen-only contraceptive (POC) and levonorgestrel-releasing intrauterine device (LNG-IUD) use among breastfeeding women?
- Use of subcutaneously-administered depot medroxyprogesterone acetate (DMPA-SC) as a new method added to the guideline.
- Sino-Implant (II) as a new method added to the guideline.
- Emergency contraceptive pills (ECPs) – Ulipristal acetate (UPA) as a new method added to the guideline; use of CYP3A4 inducers and obesity as new conditions for ECP use.
- Intrauterine device (IUD) use for women with increased risk of sexually transmitted infections (STIs).
- Use of progesterone-releasing vaginal ring as a new method added to the guideline.
- Hormonal contraception for women at high risk of HIV infection, women living with HIV, and women living with HIV using antiretroviral therapy (ART).

In addition to the recommendations themselves, the executive summary provides an introduction to the guideline, a description of the methods used to develop the recommendations for this fifth edition, and a summary of changes (from the fourth edition to the fifth edition of the MEC). It was anticipated that the Medical eligibility criteria for contraceptive use, fifth edition will be available online by 1 July 2015.

In the interim, the fourth edition of the guideline, along with this summary of new recommendations, is available online at www.who.int/reproductivehealth/publications/family_planning

TOPIC	MEC RECOMMENDATION	GRADE ASSESSMENT OF QUALITY OF EVIDENCE ^a
1. Recommendations for combined hormonal contraceptive (CHC) use by age group (CHCs include combined oral contraceptives, combined injectable contraceptives, combined patch and combined vaginal ring)		
< 40 years	Women from menarche through 40 years of age can use CHCs without restriction (MEC Category 1).	Range: Low to very low
≥ 40 years	Women 40 years and older can generally use CHCs (MEC Category 2).	
2. Recommendations for CHC use among breastfeeding women		
< 6 weeks postpartum	Breastfeeding women < 6 weeks postpartum should not use CHCs (MEC Category 4).	Range: Low to very low
≥ 6 weeks to <6 months postpartum	Breastfeeding women ≥ 6 weeks to < 6 months postpartum (primarily breastfeeding) generally should not use CHCs (MEC Category 3).	
≥ 6 months postpartum	Breastfeeding women ≥ 6 months postpartum can generally can use CHCs (MEC Category 2).	
3. Recommendations for CHC use among postpartum women		
< 21 days postpartum without other risk factors for venous thromboembolism (VTE)	Women who are < 21 days postpartum and do not have other risk factors for VTE generally should not use CHCs (MEC Category 3).	Range: Low to very low
< 21 days postpartum with other risk factors for VTE	Women who are < 21 days postpartum with other risk factors for VTE should not use CHCs (MEC Category 4).	
≥ 21 days to 42 days postpartum without other risk factors for VTE	Women who are ≥ 21 days to 42 days postpartum without other risk factors for VTE can generally use CHCs (MEC Category 2).	
≥ 21 days to 42 days postpartum with other risk factors for VTE	Women who are ≥ 21 days to 42 days postpartum with other risk factors for VTE generally should not use CHCs (MEC Category 3).	
> 42 days postpartum	Women who are > 42 days postpartum can use CHCs without restriction (MEC Category 1).	
4. Recommendations for CHC use among women with superficial venous disorders		
Varicose veins	Women with varicose veins can use CHCs without restriction (MEC Category 1).	Very low
Superficial venous thrombosis (SVT)	Women with SVT can generally use CHCs (MEC Category 2).	

TOPIC	MEC RECOMMENDATION	GRADE ASSESSMENT OF QUALITY OF EVIDENCE ^a
5. Recommendations for CHC use among women with known dyslipidaemias		
Known dyslipidaemias without other known cardiovascular risk factors	Women with known dyslipidaemias without other known cardiovascular risk factors can generally use CHCs (MEC Category 2).	Very low; reviewed for clarity as requested by the GRC
6. Recommendations for progestogen-only contraceptive (POC) and levonorgestrel-releasing intrauterine device (LNG-IUD) use among breastfeeding women		
6a. POC use among breastfeeding women (POCs include progestogen-only pills, implants and injectables)		
< 6 weeks postpartum	Breastfeeding women who are < 6 weeks postpartum can generally use progestogen-only pills (POPs) and levonorgestrel (LNG) and etonogestrel (ETG) implants (MEC Category 2). Breastfeeding women who are < 6 weeks postpartum generally should not use progestogen-only injectables (POIs) (DMPA or NET-EN) (MEC Category 3).	Range: Low to very low
≥ 6 weeks to < 6 months postpartum	Breastfeeding women who are ≥ 6 weeks to < 6 months postpartum can use POPs, POIs, and LNG and ETG implants without restriction (MEC Category 1).	
≥ 6 months postpartum	Breastfeeding women who are ≥ 6 months postpartum can use POPs, POIs, and LNG and ETG implants without restriction (MEC Category 1).	
6b. LNG-IUD use among breastfeeding women		
< 48 hours postpartum	Breastfeeding women who are < 48 hours postpartum can generally use LNG-IUDs (MEC Category 2).	Very low
≥ 48 hours to < 4 weeks postpartum	Breastfeeding women who are ≥ 48 hours to < 4 weeks postpartum generally should not have an LNG-IUD inserted (MEC Category 3).	
≥ 4 weeks postpartum	Breastfeeding women who are ≥ 4 weeks postpartum can use an LNG-IUD without restriction (MEC Category 1).	
Puerperal sepsis	Breastfeeding (and non-breastfeeding) women with puerperal sepsis should not have an LNG-IUD inserted (MEC Category 4).	
7. Recommendations for use of subcutaneously-administered depot medroxyprogesterone acetate (DMPA-SC) – new method added to the guideline		
All recommendations	Recommendations for DMPA-SC will follow the current recommendations for DMPA-IM (intramuscular).	Very low
8. Recommendations for Sino-implant (II) – new method added to the guideline		
All recommendations	Recommendations for Sino-implant (II) will follow the current recommendations for LNG implants.	Range: Moderate to very low

TOPIC	MEC RECOMMENDATION	GRADE ASSESSMENT OF QUALITY OF EVIDENCE ^a
9. Recommendations for emergency contraceptive pills (ECPs) – ulipristal acetate (UPA) as a new method added to the guideline and obesity as a new condition for ECP use		
Pregnancy	For pregnant women, ECP use is not applicable.	Very low
Breastfeeding	Breastfeeding women can use combined oral contraceptive pills (COCs) or LNG for ECPs without restriction (MEC Category 1). Women who are breastfeeding can generally use UPA for ECPs (MEC Category 2).	
Past ectopic pregnancies	Women who have experienced past ectopic pregnancies can use COCs, LNG or UPA for ECPs without restriction (MEC Category 1).	
History of severe cardiovascular disease	Women with history of severe cardiovascular disease, including ischaemic heart disease, cerebrovascular attack or other thromboembolic conditions, can generally use COCs, LNG or UPA for ECPs (MEC Category 2).	
Migraines	Women with migraines can generally use COCs, LNG or UPA for ECPs (MEC Category 2).	
Severe liver disease	Women with severe liver disease, including jaundice (a personal characteristic and sign of liver disease prior to diagnosis), can generally use COCs, LNG or UPA for ECPs (MEC Category 2).	
Use of CYP3A4 inducer	Women using CYP3A4 inducers can use COCs, LNG or UPA for ECPs without restriction (MEC Category 1).	
Repeat use of ECP	There are no restrictions on repeated use for COCs, LNG or UPA for ECPs (MEC Category 1).	
Rape	There are no restrictions for use of COCs, LNG or UPA for ECPs in cases of rape (MEC Category 1).	
Obesity	Women who are obese can use COCs, LNG or UPA for ECPs without restriction (MEC Category 1).	Moderate
10. Intrauterine device (IUD) use for women with increased risk of sexually transmitted infections (STIs)		
IUD initiation	Many women with increased risk of STIs can generally undergo either copper-bearing IUD (Cu-IUD) or LNG-IUD initiation (MEC Category 2). Some women at increased risk (very high individual likelihood) of STIs generally should not have an IUD inserted until appropriate testing and treatment occur (MEC Category 3).	No new evidence identified, so quality of evidence not evaluated using GRADE process; reviewed for clarity as requested by the GRC
IUD continuation	Women at increased risk of STIs can generally continue use of either Cu-IUD or LNG-IUD (MEC Category 2).	

TOPIC	MEC RECOMMENDATION	GRADE ASSESSMENT OF QUALITY OF EVIDENCE ^a
11. Recommendations for use of progesterone-releasing vaginal ring – new method added to the guideline		
Breastfeeding and ≥ 4 weeks postpartum	Women who are actively breastfeeding and are ≥ 4 weeks postpartum can use the progesterone-releasing vaginal ring without restrictions (MEC Category 1).	Low
12. Recommendations for use of hormonal contraception for women at high risk of HIV infection, women living with HIV, and women living with HIV using antiretroviral therapy (ART)		
12a. Women at high risk of HIV infection	<p>Women at high risk of acquiring HIV can use the following hormonal contraceptive methods without restriction: COCs, combined injectable contraceptives (CICs), combined contraceptive patches and rings, POPs, POIs (DMPA and NET-EN), and LNG and ETG implants (MEC Category 1).</p> <p>Women at high risk of acquiring HIV can generally use LNG-IUDs (MEC Category 2).</p>	Range: Moderate to very low
12b. Women living with asymptomatic or mild HIV clinical disease (WHO stage 1 or 2)	<p>Women living with asymptomatic or mild HIV clinical disease (WHO stage 1 or 2) can use the following hormonal contraceptive methods without restriction: COCs, CICs, combined contraceptive patches and rings, POPs, POIs (DMPA and NET-EN), and LNG and ETG implants (MEC Category 1).</p> <p>Women living with asymptomatic or mild HIV clinical disease (WHO stage 1 or 2) can generally use the LNG-IUD (MEC Category 2).</p>	Range: Moderate to very low
12c. Women living with severe or advanced HIV clinical disease (WHO stage 3 or 4)	<p>Women living with severe or advanced HIV clinical disease (WHO stage 3 or 4) can use the following hormonal contraceptive methods without restriction: COCs, CICs, combined contraceptive patches and rings, POPs, POIs (DMPA and NET-EN), and LNG and ETG implants (MEC Category 1).</p> <p>Women living with severe or advanced HIV clinical disease (WHO stage 3 or 4) generally should not initiate use of the LNG-IUD (MEC Category 3) until their illness has improved to asymptomatic or mild HIV clinical disease (WHO stage 1 or 2).</p> <p>Women who already have an LNG-IUD inserted and who develop severe or advanced HIV clinical disease need not have their IUD removed (MEC Category 2 for continuation).</p>	

TOPIC	MEC RECOMMENDATION	GRADE ASSESSMENT OF QUALITY OF EVIDENCE ^a
12d. Women living with HIV using antiretroviral therapy (ART)		
Nucleoside/nucleotide reverse transcriptase inhibitor (NRTI)	<p>Women taking any NRTI can use all hormonal contraceptive methods without restriction: COCs, CICs, combined contraceptive patches and rings, POPs, POIs (DMPA and NET-EN), and LNG and ETG implants (MEC Category 1).</p> <p>Women taking any NRTI can generally use the LNG-IUD (MEC Category 2), provided that their HIV clinical disease is asymptomatic or mild (WHO Stage 1 or 2). Women living with severe or advanced HIV clinical disease (WHO stage 3 or 4) and taking any NRTI generally should not initiate use of the LNG-IUD (MEC Category 3 for initiation) until their illness has improved to asymptomatic or mild HIV clinical disease.</p> <p>Women taking any NRTI who already have had an LNG-IUD inserted and who develop severe or advanced HIV clinical disease need not have their IUD removed (MEC Category 2 for continuation).</p>	Range: Low to very Low
Non-nucleoside/nucleotide reverse transcriptase inhibitors (NNRTIs) containing efavirenz or nevirapine-containing ART	<p>Women using NNRTIs containing either efavirenz or nevirapine can generally use COCs, CICs, combined contraceptive patches and rings, POPs, NET-EN, and LNG and ETG implants (MEC Category 2).</p> <p>Women using efavirenz or nevirapine can use DMPA without restriction (MEC Category 1).</p> <p>Women taking any NNRTI can generally use the LNG-IUD (MEC Category 2), provided that their HIV clinical disease is asymptomatic or mild (WHO Stage 1 or 2). Women living with severe or advanced HIV clinical disease (WHO stage 3 or 4) and taking any NNRTI generally should not initiate use of the LNG-IUD (MEC Category 3 for initiation) until their illness has improved to asymptomatic or mild HIV clinical disease.</p> <p>Women taking any NNRTI who already have had an LNG-IUD inserted and who develop severe or advanced HIV clinical disease need not have their IUD removed (MEC Category 2 for continuation).</p>	
NNRTIs containing etravirine and rilpivirine	Women using the newer NNRTIs containing etravirine and rilpivirine can use all hormonal contraceptive methods without restriction (MEC Category 1).	

TOPIC	MEC RECOMMENDATION	GRADE ASSESSMENT OF QUALITY OF EVIDENCE ^a
12d. Women living with HIV using antiretroviral therapy (ART) (continued)		
Protease inhibitors (e.g. ritonavir and ARVs boosted with ritonavir)	<p>Women using protease inhibitors (e.g. ritonavir and ARVs boosted with ritonavir) can generally use COCs, CICs, combined contraceptive patches and rings, POPs, NET-EN, and LNG and ETG implants (MEC Category 2).</p> <p>Women using protease inhibitors (e.g. ritonavir and ARVs boosted with ritonavir) can use DMPA without restriction (MEC Category 1).</p> <p>Women taking any PI can generally use the LNG-IUD (MEC Category 2), provided that their HIV clinical disease is asymptomatic or mild (WHO Stage 1 or 2). Women living with severe or advanced HIV clinical disease (WHO stage 3 or 4) and taking any PI generally should not initiate use of the LNG-IUD (MEC Category 3 for initiation) until their illness has improved to asymptomatic or mild HIV clinical disease.</p> <p>Women taking any PI who already have had an LNG-IUD inserted and who develop severe or advanced HIV clinical disease need not have their IUD removed (MEC Category 2 for continuation).</p>	Range: Low to very Low
Raltegravir (integrase inhibitor)	<p>Women using the integrase inhibitor raltegravir can use all hormonal contraceptive methods without restriction (MEC Category 1).</p> <p>Women taking an RI can generally use the LNG-IUD (MEC Category 2), provided that their HIV clinical disease is asymptomatic or mild (WHO Stage 1 or 2). Women living with severe or advanced HIV clinical disease (WHO stage 3 or 4) and taking an RI generally should not initiate use of the LNG-IUD (MEC Category 3 for initiation) until their illness has improved to asymptomatic or mild HIV clinical disease.</p> <p>Women taking an RI who already have had an LNG-IUD inserted and who develop severe or advanced HIV clinical disease need not have their IUD removed (MEC Category 2 for continuation).</p>	

For those who are familiar with the fourth edition of the MEC, the following summaries highlight changes that appear in the fifth edition of the guideline. These changes include: changes to MEC categories; recommendations for new conditions issued in the fifth edition; changes to the labelling of certain conditions (in order to be consistent with current clinical practice); and details for the new contraceptive methods included in this fifth edition.

Summary of changes from the fourth edition to the fifth edition of the MEC (changes are highlighted in bold)

Condition	COC/P/ CVR	CIC	POP	DMPA NET-EN	LNG/ ETG implants	Cu-IUD	LNG-IUD
Breastfeeding							
a) < 6 weeks postpartum	4	4	2^a	3 ^a	2^a		
b) ≥ 6 weeks to < 6 months (primarily breastfeeding)	3	3	1	1	1		
c) ≥ 6 months postpartum	2	2	1	1	1		
Postpartum (non-breastfeeding women)							
a) < 21 days			1	1	1		
(i) without other risk factors for VTE	3 ^a	3 ^a					
(ii) with other risk factors for VTE	4^a	4^a					
b) ≥ 21 days to 42 days			1	1	1		
(i) without other risk factors for VTE	2 ^a	2 ^a					
(ii) with other risk factors for VTE	3^a	3^a					
c) > 42 days	1	1	1	1	1		
Postpartum (breastfeeding or non-breastfeeding women, including after caesarean section)							
a) < 48 hours including insertion immediately after delivery of the placenta						1	not BF=1; BF=2
b) ≥ 48 hours to < 4 weeks						3	3
c) ≥ 4 weeks						1	1
d) Puerperal sepsis						4	4
Superficial venous disorders							
a) Varicose veins	1	1	1	1	1	1	1
b) Superficial venous thrombosis	2 ^a	2 ^a	1	1	1	1	1
Known dyslipidaemias without other known cardiovascular risk factors	2^a	2^a	2 ^a	2 ^a	2 ^a	1 ^a	2 ^a

Condition	COC/P/ CVR	CIC	POP	DMPA NET-EN	LNG/ ETG implants	Cu-IUD		LNG-IUD	
STIs						I	C	I	C
a) Current purulent cervicitis or chlamydial infection or gonorrhoea	1	1	1	1	1	4	2 ^a	4	2 ^a
b) Other STIs (excluding HIV and hepatitis)	1	1	1	1	1	2	2	2	2
c) Vaginitis (including Trichomonas vaginalis and bacterial vaginosis)	1	1	1	1	1	2	2	2	2
d) Increased risk of STIs	1	1	1	1	1	2/3^a	2	2/3^a	2
HIV/AIDS									
High risk of HIV	1	1	1	1^a	1	2	2	2	2
Asymptomatic or mild HIV clinical disease (WHO stage 1 or 2)	1 ^a	1 ^a	1 ^a	1 ^a	1 ^a	2	2	2	2
Severe or advanced HIV clinical disease (WHO stage 3 or 4)	1 ^a	1 ^a	1 ^a	1 ^a	1 ^a	3	2 ^a	3	2 ^a
Antiretroviral therapy						I	C	I	C
a) Nucleoside reverse transcriptase inhibitors (NRTIs)									
Abacavir (ABC)	1	1	1	1	1	2/3^a	2^a	2/3^a	2^a
Tenofovir (TDF)	1	1	1	1	1	2/3^a	2^a	2/3^a	2^a
Zidovudine (AZT)	1	1	1	1	1	2/3^a	2^a	2/3^a	2^a
Lamivudine (3TC)	1	1	1	1	1	2/3^a	2^a	2/3^a	2^a
Didanosine (DDI)	1	1	1	1	1	2/3^a	2^a	2/3^a	2^a
Emtricitabine (FTC)	1	1	1	1	1	2/3^a	2^a	2/3^a	2^a
Stavudine (D4T)	1	1	1	1	1	2/3^a	2^a	2/3^a	2^a
b) Non-nucleoside reverse transcriptase inhibitors (NNRTIs)									
Efavirenz (EFV)	2^a	2^a	2^a	1 = DMPA; 2 = NET-EN^a	2^a	2/3^a	2^a	2/3^a	2^a
Etravirine (ETR)	1	1	1	1	1	2/3^a	2^a	2/3^a	2^a
Nevirapine (NVP)	2^a	2^a	2^a	1 = DMPA; 2 = NET-EN^a	2^a	2/3^a	2^a	2/3^a	2^a
Rilpivirine (RPV)	1	1	1	1	1	2/3^a	2^a	2/3^a	2^a
c) Protease inhibitors (PIs)									
Ritonavir-boosted atazanavir (ATV/r)	2^a	2^a	2^a	1 = DMPA; 2 = NET-EN^a	2^a	2/3^a	2^a	2/3^a	2^a
Ritonavir-boosted lopinavir (LPV/r)	2^a	2^a	2^a	1 = DMPA; 2 = NET-EN^a	2^a	2/3^a	2^a	2/3^a	2^a

Condition	COC/P/ CVR	CIC	POP	DMPA NET-EN	LNG/ ETG implants	Cu-IUD		LNG-IUD	
Ritonavir-boosted darunavir (DRV/r)	2^a	2^a	2^a	1 = DMPA; 2 = NET-EN ^a	2^a	2/3^a	2^a	2/3^a	2^a
Ritonavir (RTV)	2^a	2^a	2^a	1 = DMPA; 2 = NET-EN ^a	2^a	2/3^a	2^a	2/3^a	2^a
d) Integrase inhibitors									
Raltegravir (ral)	1	1	1	1	1	2/3^a	2^a	2/3^a	2^a

^a Please consult the relevant table for each contraceptive method in full document, for a clarification to this classification.

Progesterone-releasing vaginal ring (PVR) (changes are highlighted in bold)

Condition	Category
Pregnancy	NA
Breastfeeding and ≥ 4 weeks postpartum	1

Emergency contraceptive pills (ECPs) (changes are highlighted in bold)

Condition	COC	LNG	UPA
Pregnancy	NA ^a	NA ^a	NA^a
Breastfeeding	1	1	2^a
Past ectopic pregnancy	1	1	1
Obesity	1^a	1^a	1^a
History of severe cardiovascular disease (ischaemic heart disease, cerebrovascular attack, or other thromboembolic conditions)	2	2	2
Migraine	2	2	2
Severe liver disease (including jaundice)	2	2	2
CYP3A4 inducers (e.g. rifampicin, phenytoin, phenobarbital, carbamazepine, efavirenz, fosphenytoin, nevirapine, oxcarbazepine, primidone, rifabutin, St Johns wort/Hypericum perforatum)	1^a	1^a	1^a
Repeated ECP use	1 ^a	1 ^a	1^a
Rape	1	1	1

^a Please consult the relevant table for each contraceptive method in the full document, for a clarification to this classification.

Summary table

This summary table highlights the medical eligibility recommendations for combined hormonal contraceptives (COC, CIC, patch [P] and vaginal ring [CVR]), progestogen-only contraceptives (POP, DMPA/NET-EN injectables, and LNG/ETG implants) and intrauterine devices (Cu-IUD and LNG-IUD). For further information about these recommendations, please consult the corresponding method tables. Eligibility recommendations for emergency contraceptive pills (ECPs), IUDs for emergency contraception (E-IUD), progesterone-releasing vaginal rings (PVR), barrier methods (BARR), fertility awareness-based (FAB) methods, lactational amenorrhea method (LAM), coitus interruptus (CI) and surgical sterilization (STER) are presented in their respective sub-sections in this document.

SUMMARY TABLE							
	COC//P/CVR	CIC	POP	DMPA/NET-EN	LNG/ETG/ IMPLANTS	CU-IUD	LNG-IUD
PREGNANCY	NA ^a	NA ^a	NA ^a	NA ^a	NA ^a	NA ^a	NA ^a
AGE	Menarche to < 40=1 ≥ 40=2	Menarche to < 40=1 ≥ 40=2	Menarche to < 18=1 18-45=1 > 45=1	Menarche to < 18=2 18-45=1 > 45=2	Menarche to < 18=1 18-45=1 > 45=1	Menarche to < 20=2 ≥ 20=1	Menarche to < 20=2 ≥ 20=1
PARITY							
a) Nulliparous	1	1	1	1	1	2	2
b) Parous	1	1	1	1	1	1	1
BREASTFEEDING							
a) < 6 weeks postpartum	4	4	2 ^a	3 ^a	2 ^a		
b) ≥ 6 weeks to < 6 months (primarily breastfeeding)	3	3	1	1	1		
c) ≥ 6 months postpartum	2	2	1	1	1		
POSTPARTUM (non-breastfeeding women)							
a) < 21 days			1	1	1		
i) without other risk factors for venous thromboembolism (VTE)	3 ^a	3 ^a					
ii) with other risk factors for VTE	4 ^a	4 ^a					
b) ≥ 21 days to 42 days			1	1	1		
i) without other risk factors for VTE	2 ^a	2 ^a					
ii) with other risk factors for VTE	3 ^a	3 ^a					
c) > 42 days	1	1	1	1	1		

SUMMARY TABLE							
	COC/P/CVR	CIC	POP	DMPA/NET-EN	LNG/ETG/ IMPLANTS	CU-IUD	LNG-IUD
POSTPARTUM (breastfeeding or non-breastfeeding women, including after caesarean section)							
a) < 48 hours including insertion immediately after delivery of the placenta						1	not BF=1; BF=2
b) ≥ 48 hours to < 4 weeks						3	3
c) ≥ 4 weeks						1	1
d) Puerperal sepsis						4	4
POST-ABORTION							
a) First trimester	1 ^a	1 ^a	1 ^a	1 ^a	1 ^a	1 ^a	1 ^a
b) Second trimester	1 ^a	1 ^a	1 ^a	1 ^a	1 ^a	2 ^a	2 ^a
c) Immediate post-septic abortion	1 ^a	1 ^a	1 ^a	1 ^a	1 ^a	4	4
PAST ECTOPIC PREGNANCY	1	1	2	1	1	1	1
HISTORY OF PELVIC SURGERY (see postpartum, including caesarean section)	1	1	1	1	1	1	1
SMOKING							
a) Age < 35 years	2	2	1	1	1	1	1
b) Age ≥ 35 years							
i) < 15 cigarettes/day	3	2	1	1	1	1	1
ii) ≥ 15 cigarettes/day	4	3	1	1	1	1	1

SUMMARY TABLE							
	COC//P/CVR	CIC	POP	DMPA/NET-EN	LNG/ETG/ IMPLANTS	CU-IUD	LNG-IUD
OBESITY							
a) ≥ 30 kg/m ² BMI	2	2	1	1	1	1	1
b) Menarche to < 18 years and ≥ 30 kg/m ² BMI	2	2	1	2 ^a	1	1	1
BLOOD PRESSURE MEASUREMENT UNAVAILABLE	NA ^a	NA ^a	NA ^a	NA ^a	NA ^a	NA ^a	NA ^a
CARDIOVASCULAR DISEASE							
MULTIPLE RISK FACTORS FOR ARTERIAL CARDIOVASCULAR DISEASE (such as older age, smoking, diabetes, hypertension and known dyslipidaemias)	3/4 ^a	3/4 ^a	2 ^a	3 ^a	2 ^a	1	2
HYPERTENSION							
a) History of hypertension where blood pressure CANNOT be evaluated (including hypertension during pregnancy)	3 ^a	3 ^a	2 ^a	2 ^a	2 ^a	1	2
b) Adequately controlled hypertension, where blood pressure CAN be evaluated	3 ^a	3 ^a	1 ^a	2 ^a	1 ^a	1	1
c) Elevated blood pressure levels (properly taken measurements)							
i) systolic 140–159 or diastolic 90–99 mm Hg	3	3	1	2	1	1	1
ii) systolic ≥ 160 or diastolic ≥ 100 mm Hg	4	4	2	3	2	1	2
d) Vascular disease	4	4	2	3	2	1	2

SUMMARY TABLE							
	COC/P/CVR	CIC	POP	DMPA/NET-EN	LNG/ETG/ IMPLANTS	CU-IUD	LNG-IUD
HISTORY OF HIGH BLOOD PRESSURE DURING PREGNANCY (where current blood pressure is measurable and normal)	2	2	1	1	1	1	1
DEEP VEIN THROMBOSIS (DVT)/ PULMONARY EMBOLISM (PE)							
a) History of DVT/PE	4	4	2	2	2	1	2
b) Acute DVT/PE	4	4	3	3	3	1	3
c) DVT/PE and established on anticoagulant therapy	4	4	2	2	2	1	2
d) Family history (first-degree relatives)	2	2	1	1	1	1	1
e) Major surgery							
i) with prolonged immobilization	4	4	2	2	2	1	2
ii) without prolonged immobilization	2	2	1	1	1	1	1
f) Minor surgery without immobilization	1	1	1	1	1	1	1
KNOWN THROMBOGENIC MUTATIONS (e.g. factor V Leiden; prothrombin mutation; protein S, protein C, and antithrombin deficiencies)	4 ^a	4 ^a	2 ^a	2 ^a	2 ^a	1 ^a	2 ^a

SUMMARY TABLE									
	COC/P/CVR	CIC	POP	DMPA/NET-EN	LNG/ETG/ IMPLANTS	CU-IUD	LNG-IUD		
SUPERFICIAL VENOUS DISORDERS	1	1	1	1	1	1	1		
	2 ^a	2 ^a	1	1	1	1	1		
CURRENT AND HISTORY OF ISCHAEMIC HEART DISEASE	4	4	I	C	I	C	I	C	
			2	3	2	3	2	3	1
STROKE (history of cerebrovascular accident)	4	4	I	C	I	C	I	C	
			2	3	2	3	2	3	1
KNOWN DYSLIPIDAEMIAS WITHOUT OTHER KNOWN CARDIOVASCULAR RISK FACTORS	2 ^a	2 ^a	2 ^a	2 ^a	2 ^a	2 ^a	1 ^a	2 ^a	
VALVULAR HEART DISEASE	2	2	1	1	1	1	1	1	
			4	4	1	1	2 ^a	2 ^a	1
a) Uncomplicated									
b) Complicated (pulmonary hypertension, risk of atrial fibrillation, history of subacute bacterial endocarditis)									

SUMMARY TABLE										
	COC/P/CVR	CIC	POP	DMPA/NET-EN	LNG/ETG/ IMPLANTS	CU-IUD	LNG-IUD			
RHEUMATIC DISEASES										
SYSTEMIC LUPUS ERYTHEMATOSUS										
a) Positive (or unknown) antiphospholipid antibodies	4	4	3	I 3 C 3	3	I 1 C 1	3			
b) Severe thrombocytopenia	2	2	2	3	2	3 ^a	2 ^a			
c) Immunosuppressive treatment	2	2	2	2	2	2	1			
d) None of the above	2	2	2	2	2	1	1			
NEUROLOGIC CONDITIONS										
HEADACHES										
a) Non-migrainous (mild or severe)	1 ^a	1 ^a	1 ^a	1 ^a	1 ^a	1 ^a	1 ^a	1 ^a	1 ^a	1 ^a
b) Migraine										
i) without aura										
age < 35 years	2 ^a	2 ^a	1 ^a	2 ^a	2 ^a	2 ^a	1 ^a	2 ^a	2 ^a	2 ^a
age ≥ 35 years	3 ^a	3 ^a	1 ^a	2 ^a	2 ^a	2 ^a	1 ^a	2 ^a	2 ^a	2 ^a
ii) with aura (at any age)	4 ^a	4 ^a	2 ^a	2 ^a	4 ^a	3 ^a	2 ^a	2 ^a	2 ^a	3 ^a
EPILEPSY	1 ^a	1 ^a	1 ^a	1 ^a	1 ^a	1 ^a	1 ^a	1 ^a	1 ^a	1 ^a
If on treatment, see DRUG INTERACTIONS (last section of this table)										
DEPRESSIVE DISORDERS										
DEPRESSIVE DISORDERS	1 ^a	1 ^a	1 ^a	1 ^a	1 ^a	1 ^a	1 ^a	1 ^a	1 ^a	1 ^a

SUMMARY TABLE							
	COC/P/CVR	CIC	POP	DMPA/NET-EN	LNG/ETG/ IMPLANTS	CU-IUD	LNG-IUD
REPRODUCTIVE TRACT INFECTIONS AND DISORDERS							
VAGINAL BLEEDING PATTERNS							
a) Irregular pattern without heavy bleeding	1	1	2	2	2	1	I 1
b) Heavy or prolonged bleeding (includes regular and irregular patterns)	1 ^a	1 ^a	2 ^a	2 ^a	2 ^a	2 ^a	1 ^a 2 ^a
UNEXPLAINED VAGINAL BLEEDING (suspicious for serious condition)						I C	I C
a) Before evaluation	2 ^a	2 ^a	2 ^a	3 ^a	3 ^a	4 ^a 2 ^a	4 ^a 2 ^a
ENDOMETRIOSIS	1	1	1	1	1	2	1
BENIGN OVARIAN TUMOURS (INCLUDING CYSTS)	1	1	1	1	1	1	1
SEVERE DYSMENORRHOEA	1	1	1	1	1	2	1
GESTATIONAL TROPHOBLASTIC DISEASE							
a) Decreasing or undetectable β-hCG levels	1	1	1	1	1	3	3
b) Persistently elevated β-hCG levels or malignant disease	1	1	1	1	1	4	4
CERVICAL ECTROPION	1	1	1	1	1	1	1
CERVICAL INTRAEPITHELIAL NEOPLASIA (CIN)	2	2	1	2	2	1	2

SUMMARY TABLE										
	COC//P/CVR	CIC	POP	DMPA/NET-EN	LNG/ETG/ IMPLANTS	CU-IUD		LNG-IUD		
						I	C	I	C	
CERVICAL CANCER (AWAITING TREATMENT)	2	2	1	2	2		I	C	I	C
BREAST DISEASE							4	2	4	2
a) Undiagnosed mass	2 ^a	2 ^a	2 ^a	2 ^a	2 ^a		1	1	2	2
b) Benign breast disease	1	1	1	1	1		1	1	1	1
c) Family history of cancer	1	1	1	1	1		1	1	1	1
d) Breast cancer										
i) current	4	4	4	4	4		1	1	4	4
ii) past and no evidence of current disease for 5 years	3	3	3	3	3		1	1	3	3
ENDOMETRIAL CANCER										
	1	1	1	1	1		I	C	I	C
							4	2	4	2
OVARIAN CANCER										
	1	1	1	1	1		I	C	I	C
							3	2	3	2
UTERINE FIBROIDS										
a) Without distortion of the uterine cavity	1	1	1	1	1		1	1	1	1
b) With distortion of the uterine cavity	1	1	1	1	1		4	4	4	4

SUMMARY TABLE									
	COC//P/CVR	CIC	POP	DMPA/NET-EN	LNG/ETG/ IMPLANTS	CU-IUD	LNG-IUD		
ANATOMICAL ABNORMALITIES									
a) That distort the uterine cavity						4	4		
b) That do not distort the uterine cavity						2	2		
PELVIC INFLAMMATORY DISEASE (PID)									
a) Past PID (assuming no current risk factors for sexually transmitted infections)									
i) with subsequent pregnancy	1	1	1	1	1	1	1	1	1
ii) without subsequent pregnancy	1	1	1	1	1	2	2	2	2
b) PID current	1	1	1	1	1	4	2 ^a	4	2 ^a
SEXUALLY TRANSMITTED INFECTIONS (STIS)									
a) Current purulent cervicitis or chlamydial infection or gonorrhoea	1	1	1	1	1	4	2 ^a	4	2 ^a
b) Other STIs (excluding HIV and hepatitis)	1	1	1	1	1	2	2	2	2
c) Vaginitis (including <i>Trichomonas vaginalis</i> and bacterial vaginosis)	1	1	1	1	1	2	2	2	2
d) Increased risk of STIs	1	1	1	1	1	2/3 ^a	2	2/3 ^a	2

SUMMARY TABLE									
	COC//P/CVR	CIC	POP	DMPA/NET-EN	LNG/ETG/ IMPLANTS	CU-IUD		LNG-IUD	
						I	C	I	C
HIV/AIDS									
HIGH RISK OF HIV	1	1	1	1 ^a	1	2	2	2	2
ASYMPTOMATIC OR MILD HIV CLINICAL DISEASE (WHO STAGE 1 OR 2)	1 ^a	1 ^a	1 ^a	1 ^a	1 ^a	2	2	2	2
SEVERE OR ADVANCED HIV CLINICAL DISEASE (WHO STAGE 3 OR 4)	1 ^a	1 ^a	1 ^a	1 ^a	1 ^a	3	2 ^a	3	2 ^a
OTHER INFECTIONS									
SCHISTOSOMIASIS									
a) Uncomplicated	1	1	1	1	1	1	1	1	1
b) Fibrosis of the liver	1	1	1	1	1	1	1	1	1
TUBERCULOSIS									
a) Non-pelvic	1 ^a	1 ^a	1 ^a	1 ^a	1 ^a	1	1	1	1
b) Pelvic	1 ^a	1 ^a	1 ^a	1 ^a	1 ^a	4	3	4	3
MALARIA	1	1	1	1	1	1	1	1	1

SUMMARY TABLE							
	COC//P/CVR	CIC	POP	DMPA/NET-EN	LNG/ETG/ IMPLANTS	CU-IUD	LNG-IUD
ENDOCRINE CONDITIONS							
DIABETES							
a) History of gestational disease	1	1	1	1	1	1	1
b) Non-vascular disease							
i) non-insulin-dependent	2	2	2	2	2	1	2
ii) insulin-dependent	2	2	2	2	2	1	2
c) Nephropathy/retinopathy/neuropathy	3/4 ^a	3/4 ^a	2	3	2	1	2
d) Other vascular disease or diabetes of > 20 years' duration	3/4 ^a	3/4 ^a	2	3	2	1	2
THYROID DISORDERS							
a) Simple goitre	1	1	1	1	1	1	1
b) Hyperthyroid	1	1	1	1	1	1	1
c) Hypothyroid	1	1	1	1	1	1	1
GASTROINTESTINAL CONDITIONS							
GALL BLADDER DISEASE							
a) Symptomatic							
i) treated by cholecystectomy	2	2	2	2	2	1	2
ii) medically treated	3	2	2	2	2	1	2
iii) current	3	2	2	2	2	1	2
b) Asymptomatic	2	2	2	2	2	1	2

SUMMARY TABLE										
	COC//P/CVR			CIC		POP	DMPA/NET-EN	LNG/ETG/ IMPLANTS	CU-IUD	LNG-IUD
HISTORY OF CHOLESTASIS										
a) Pregnancy-related	2			2		1	1	1	1	1
b) Past-COC-related	3			2		2	2	2	1	2
VIRAL HEPATITIS										
a) Acute or flare		C		I	C					
	3/4 ^a	2	3	2		1	1	1	1	1
b) Carrier	1	1	1	1		1	1	1	1	1
c) Chronic	1	1	1	1		1	1	1	1	1
CIRRHOSIS										
a) Mild (compensated)	1			1		1	1	1	1	1
b) Severe (decompensated)	4			3		3	3	3	1	3
LIVER TUMOURS										
a) Benign										
i) focal nodular hyperplasia	2			2		2	2	2	1	2
ii) hepatocellular adenoma	4			3		3	3	3	1	3
b) Malignant (hepatoma)	4			3/4		3	3	3	1	3
ANAEMIAS										
Thalassaemia	1			1		1	1	1	2	1
Sickle cell disease	2			2		1	1	1	2	1
Iron-deficiency anaemia	1			1		1	1	1	2	1

SUMMARY TABLE									
DRUG INTERACTIONS	COC//P/CVR	CIC	POP	DMPA/NET-EN	LNG/ETG/ IMPLANTS	CU-IUD	LNG-IUD		
ANTIRETROVIRAL THERAPY (ART)									
a) Nucleoside reverse transcriptase inhibitors (NRTIs)								I	C
Abacavir (ABC)	1	1	1	1	1	2 ^a	2 ^a	2/3 ^a	2 ^a
Tenofovir (TDF)	1	1	1	1	1	2 ^a	2 ^a	2/3 ^a	2 ^a
Zidovudine (AZT)	1	1	1	1	1	2 ^a	2 ^a	2/3 ^a	2 ^a
Lamivudine (3TC)	1	1	1	1	1	2 ^a	2 ^a	2/3 ^a	2 ^a
Didanosine (DDI)	1	1	1	1	1	2 ^a	2 ^a	2/3 ^a	2 ^a
Emtricitabine (FTC)	1	1	1	1	1	2 ^a	2 ^a	2/3 ^a	2 ^a
Stavudine (D4T)	1	1	1	1	1	2 ^a	2 ^a	2/3 ^a	2 ^a
b) Non-nucleoside reverse transcriptase inhibitors (NNRTIs)								I	C
Efavirenz (EFV)	2 ^a	2 ^a	2 ^a	DMPA=1, NET-EN=2 ^a	2 ^a	2 ^a	2 ^a	2/3 ^a	2 ^a
Etravirine (ETR)	1	1	1	1	1	2 ^a	2 ^a	2/3 ^a	2 ^a
Nevirapine (NVP)	2 ^a	2 ^a	2 ^a	DMPA=1, NET-EN=2 ^a	2 ^a	2 ^a	2 ^a	2/3 ^a	2 ^a
Rilpivirine (RPV)	1	1	1	1	1	2 ^a	2 ^a	2/3 ^a	2 ^a
c) Protease inhibitors (PIs)								I	C
Ritonavir-boosted atazanavir (ATV/r)	2 ^a	2 ^a	2 ^a	DMPA=1, NET-EN=2 ^a	2 ^a	2 ^a	2 ^a	2/3 ^a	2 ^a
Ritonavir-boosted lopinavir (LPV/r)	2 ^a	2 ^a	2 ^a	DMPA=1, NET-EN=2 ^a	2 ^a	2 ^a	2 ^a	2/3 ^a	2 ^a
Ritonavir-boosted darunavir (DRV/r)	2 ^a	2 ^a	2 ^a	DMPA=1, NET-EN=2 ^a	2 ^a	2 ^a	2 ^a	2/3 ^a	2 ^a
Ritonavir (RTV)	2 ^a	2 ^a	2 ^a	DMPA=1, NET-EN=2 ^a	2 ^a	2 ^a	2 ^a	2/3 ^a	2 ^a
d) Integrase inhibitors								I	C
Raltegravir (RAL)	1	1	1	1	1	2 ^a	2 ^a	2/3 ^a	2 ^a

SUMMARY TABLE							
	COC/P/CVR	CIC	POP	DMPA/NET-EN	LNG/ETG/ IMPLANTS	CU-IUD	LNG-IUD
ANTICONVULSANT THERAPY							
a) Certain anticonvulsants (phenytoin, carbamazepine, barbiturates, primidone, topiramate, oxcarbazepine)	3 ^a	2	3 ^a	DMPA=1, NET-EN=2 ^a	2 ^a	1	1
b) Lamotrigine	3 ^a	3	1	1	1	1	1
ANTIMICROBIAL THERAPY							
a) Broad-spectrum antibiotics	1	1	1	1	1	1	1
b) Antifungals	1	1	1	1	1	1	1
c) Antiparasitics	1	1	1	1	1	1	1
d) Rifampicin or rifabutin therapy	3 ^a	2 ^a	3 ^a	DMPA=1, NET-EN=2 ^a	2 ^a	1	1

^a Please consult the tables in the text for a clarification to this classification.

Additional conditions relating to emergency contraceptive Pills

Category 1: Repeated use; rape.

Category 2: History of severe cardiovascular complications (ischemic heart disease, cerebrovascular attack, or other thromboembolic conditions).

Additional conditions relating to Female Sterilization

Caution: Diaphragmatic hernia; kidney disease; severe nutritional deficiencies; previous abdominal or pelvic surgery; concurrent with elective surgery.

Delay: Abdominal skin infection; acute respiratory disease (bronchitis, pneumonia); systemic infection or gastroenteritis; emergency surgery (without previous counselling); surgery for an infectious condition; certain postpartum conditions (7–41 days after childbirth); severe pre-eclampsia/ eclampsia; prolonged rupture of membranes (24 hours or more); fever during or immediately after delivery; sepsis after delivery; severe haemorrhage; severe trauma to the genital tract; cervical or vaginal tear (at time of delivery); certain postabortion conditions (sepsis, fever, or severe haemorrhage; severe trauma to the genital tract; cervical or vaginal tear at time of abortion; acute haematometra); sub-acute bacterial endocarditis; unmanaged atrial fibrillation.

Special arrangements: Coagulation disorders; chronic asthma, bronchitis, emphysema, or lung infection; fixed uterus due to previous surgery or infection; abdominal wall or umbilical hernia; postpartum uterine rupture or perforation; postabortion uterine perforation.

Conditions relating to Vasectomy

No special considerations: High risk of HIV, HIV-infected, sickle cell disease. Caution: Young age; depressive disorders; diabetes; previous scrotal injury; hydrocele; cryptorchidism (may require referral).

Delay: Active STIs (excluding HIV and hepatitis); scrotal skin infection; balanitis; epididymitis or orchitis; systemic infection or gastroenteritis; filariasis; elephantiasis; intrascrotal mass.

Special arrangements: AIDS (AIDS-related illness may require delay); coagulation disorders; inguinal hernia.

FEMALE SURGICAL STERILIZATION

Sterilization does not protect against sexually transmitted infections (STIs), including HIV. If there is a risk of STI/HIV, the correct and consistent use of condoms is recommended. When used correctly and consistently, condoms offer one of the most effective methods of protection against STIs, including HIV. Female condoms are effective and safe, but are not used as widely by national programmes as male condoms.

CONDITION * additional comments after this table	CATEGORY^a A = accept, C = caution, D = delay, S = special	CLARIFICATIONS/EVIDENCE
PERSONAL CHARACTERISTICS AND REPRODUCTIVE HISTORY		
PREGNANCY	D	
YOUNG AGE	C	<p>Clarification: Young women, like all women, should be counselled about the permanency of sterilization and the availability of alternative, long-term, highly effective methods.</p> <p>Evidence: Studies show that up to 20% of women sterilized at a young age later regret this decision, and that young age is one of the strongest predictors of regret (including request for referral information and obtaining reversal) that can be identified before sterilization (1–19).</p>
PARITY* a) Nulliparous b) Parous	A A	
BREASTFEEDING	A	

FEMALE SURGICAL STERILIZATION

Sterilization does not protect against sexually transmitted infections (STIs), including HIV. If there is a risk of STI/HIV, the correct and consistent use of condoms is recommended. When used correctly and consistently, condoms offer one of the most effective methods of protection against STIs, including HIV. Female condoms are effective and safe, but are not used as widely by national programmes as male condoms

CONDITION * additional comments after this table	CATEGORY^a A = accept, C = caution, D = delay, S = special	CLARIFICATIONS/EVIDENCE
POSTPARTUM* a) < 7 days 7 to < 42 days ≥ 42 days b) Pre-eclampsia/eclampsia i) mild pre-eclampsia ii) severe pre-eclampsia/ eclampsia c) Prolonged rupture of membranes, 24 hours or more d) Puerperal sepsis, intrapartum or puerperal fever e) Severe antepartum or postpartum haemorrhage f) Severe trauma to the genital tract (cervical or vaginal tear at time of delivery) g) Uterine rupture or perforation	A D A A D D D D D S	Clarification: If exploratory surgery or laparoscopy is conducted and the patient is stable, repair of the problem and tubal sterilization may be performed concurrently if no additional risk is involved.
POST-ABORTION* a) Uncomplicated b) Post-abortal sepsis or fever c) Severe post-abortal haemorrhage d) Severe trauma to the genital tract (cervical or vaginal tear at time of abortion) e) Uterine perforation f) Acute haematometra	A D D D S D	Clarification: If exploratory surgery or laparoscopy is conducted and the patient is stable, repair of the problem and tubal sterilization may be performed concurrently if no additional risk is involved.
PAST ECTOPIC PREGNANCY	A	

FEMALE SURGICAL STERILIZATION		
Sterilization does not protect against sexually transmitted infections (STIs), including HIV. If there is a risk of STI/HIV, the correct and consistent use of condoms is recommended. When used correctly and consistently, condoms offer one of the most effective methods of protection against STIs, including HIV. Female condoms are effective and safe, but are not used as widely by national		
I d		
CONDITION * additional comments after this table	CATEGORY ^a A = accept, C = caution, D = delay, S = special	CLARIFICATIONS/EVIDENCE
a) Age < 35 years b) Age ≥ 35 years i) < 15 cigarettes/day ii) ≥ 15 cigarettes/day	A A A	
OBESITY a) ≥ 30 kg/m ² BMI b) Menarche to < 18 years and ≥ 30 kg/m ² BMI	C C	Clarification: The procedure may be more difficult. There is an increased risk of wound infection and disruption. Obese women may have limited respiratory function and may be more likely to require general anaesthesia. Evidence: Obese women were more likely to have complications when undergoing sterilization (20–23).
CARDIOVASCULAR DISEASE		
MULTIPLE RISK FACTORS FOR ARTERIAL CARDIOVASCULAR DISEASE* (such as older age, smoking, diabetes, hypertension and known dyslipidaemias)	S	
HYPERTENSION		
For all categories of hypertension, classifications are based on the assumption that no other risk factors for cardiovascular disease exist. When multiple risk factors do exist, the risk of cardiovascular disease may increase substantially. A single reading of blood pressure level is not sufficient to classify a woman as hypertensive.		
a) Hypertension: adequately controlled b) Elevated blood pressure levels (properly taken measurements) i) systolic 140–159 or diastolic 90–99 mm Hg ii) systolic ≥ 160 or diastolic ≥ 100 mm Hg c) Vascular disease	C C S S	Clarification: Elevated blood pressure should be controlled before surgery. There are increased anaesthesia-related risks and an increased risk of cardiac arrhythmia with uncontrolled hypertension. Careful monitoring of blood pressure intra-operatively is particularly necessary in this situation.
HISTORY OF HIGH BLOOD PRESSURE DURING PREGNANCY (where current blood pressure is measurable and normal)	A	

FEMALE SURGICAL STERILIZATION		
Sterilization does not protect against sexually transmitted infections (STIs), including HIV. If there is a risk of STI/HIV, the correct and consistent use of condoms is recommended. When used correctly and consistently, condoms offer one of the most effective methods of protection against STIs, including HIV. Female condoms are effective and safe, but are not used as widely by national		
CONDITION * additional comments after this table	CATEGORY ^a A = accept, C = caution, D = delay, S = special	CLARIFICATIONS/EVIDENCE
DEEP VEIN THROMBOSIS (DVT)/ PULMONARY EMBOLISM (PE) a) History of DVT/PE b) Acute DVT/PE c) DVT/PE and established on anticoagulant therapy d) Family history (first-degree relatives) e) Major surgery i) with prolonged immobilization ii) without prolonged immobilization f) Minor surgery without immobilization	 A D S A D A A	Clarification: To reduce the risk of DVT/PE, early ambulation is recommended.
KNOWN THROMBOGENIC MUTATIONS (e.g. factor V Leiden; prothrombin mutation; protein S, protein C, and antithrombin deficiencies)	A	Clarification: Routine screening is not appropriate because of the rarity of the conditions and the high cost of screening.
SUPERFICIAL VEIN DISORDERS a) Varicose veins b) Superficial venous thrombosis	 A A	
CURRENT AND HISTORY OF ISCHAEMIC HEART DISEASE* a) Current ischaemic heart disease b) History of ischaemic heart disease	 D C	
STROKE (history of cerebrovascular accident)	C	
KNOWN DYSLIPIDAEMIAS WITHOUT OTHER KNOWN CARDIOVASCULAR RISK FACTORS	A	Clarification: Routine screening is not appropriate because of the rarity of the condition and the high cost of screening.
VALVULAR HEART DISEASE a) Uncomplicated b) Complicated (pulmonary hypertension, risk of atrial fibrillation, history of subacute bacterial endocarditis)	 C S	Clarification: The woman requires prophylactic antibiotics. Clarification: The woman is at high risk for complications associated with anaesthesia and surgery. If the woman has atrial fibrillation that has not been successfully managed or current subacute bacterial endocarditis, the procedure should be delayed.

FEMALE SURGICAL STERILIZATION

Sterilization does not protect against sexually transmitted infections (STIs), including HIV. If there is a risk of STI/HIV, the correct and consistent use of condoms is recommended. When used correctly and consistently, condoms offer one of the most effective methods of protection against STIs, including HIV. Female condoms are effective and safe, but are not used as widely by national programmes as male condoms

CONDITION * additional comments after this table	CATEGORY ^a A = accept, C = caution, D = delay, S = special	CLARIFICATIONS/EVIDENCE
---	---	-------------------------

RHEUMATIC DISEASES

SYSTEMIC LUPUS ERYTHEMATOSUS (SLE)

People with SLE are at increased risk of ischaemic heart disease, stroke and venous thromboembolism. Categories assigned to such conditions in the MEC should be the same for women with SLE who present with these conditions. For all categories of SLE, classifications are based on the assumption that no other risk factors for cardiovascular disease are present; these classifications must be modified in the presence of such risk factors. Available evidence indicates that many women with SLE can be considered good candidates for most contraceptive methods, including hormonal contraceptives (24–42).

a) Positive (or unknown) antiphospholipid antibodies	S	
b) Severe thrombocytopenia	S	
c) Immunosuppressive treatment	S	
d) None of the above	C	

NEUROLOGIC CONDITIONS

HEADACHES

a) Non-migrainous (mild or severe)	A	
b) Migraine		
i) without aura		
age < 35 years	A	
age ≥ 35 years	A	
ii) with aura, at any age	A	

EPILEPSY	C	
----------	---	--

DEPRESSIVE DISORDERS

DEPRESSIVE DISORDERS	C	
----------------------	---	--

REPRODUCTIVE TRACT INFECTIONS AND DISORDERS

VAGINAL BLEEDING PATTERNS

a) Irregular pattern without heavy bleeding	A	
b) Heavy or prolonged bleeding (includes regular and irregular patterns)	A	

UNEXPLAINED VAGINAL BLEEDING (suspicious for serious condition)

a) Before evaluation	D	Clarification: The condition must be evaluated before the procedure is performed.
----------------------	---	---

FEMALE SURGICAL STERILIZATION

Sterilization does not protect against sexually transmitted infections (STIs), including HIV. If there is a risk of STI/HIV, the correct and consistent use of condoms is recommended. When used correctly and consistently, condoms offer one of the most effective methods of protection against STIs, including HIV. Female condoms are effective and safe, but are not used as widely by national programmes as male condoms.

CONDITION * additional comments after this table	CATEGORY ^a A = accept, C = caution, D = delay, S = special	CLARIFICATIONS/EVIDENCE
BENIGN OVARIAN TUMOURS (including cysts)	A	
SEVERE DYSMENORRHOEA	A	
GESTATIONAL TROPHOBLASTIC DISEASE		
a) Decreasing or undetectable β -hCG levels	A	
b) Persistently elevated β -hCG levels or malignant disease	D	
CERVICAL ECTROPION	A	
CERVICAL INTRAEPITHELIAL NEOPLASIA (CIN)	A	
CERVICAL CANCER* (awaiting treatment)	D	
BREAST DISEASE		
a) Undiagnosed mass	A	
b) Benign breast disease	A	
c) Family history of cancer	A	
d) Breast cancer		
i) current	C	
ii) past and no evidence of current disease for 5 years	A	
ENDOMETRIAL CANCER*	D	
OVARIAN CANCER*	D	
UTERINE FIBROIDS*		
a) Without distortion of the uterine cavity	C	
b) With distortion of the uterine cavity	C	

FEMALE SURGICAL STERILIZATION		
Sterilization does not protect against sexually transmitted infections (STIs), including HIV. If there is a risk of STI/HIV, the correct and consistent use of condoms is recommended. When used correctly and consistently, condoms offer one of the most effective methods of protection against STIs, including HIV. Female condoms are effective and safe, but are not used as widely by national		
CONDITION * additional comments after this table	CATEGORY ^a A = accept, C = caution, D = delay, S = special	CLARIFICATIONS/EVIDENCE
(PID)* a) Past PID (assuming no current risk factors for STIs) i) with subsequent pregnancy ii) without subsequent pregnancy b) PID – current	A C D	Clarification: A careful pelvic examination must be performed to rule out recurrent or persistent infection and to determine the mobility of the uterus.
STIS* a) Current purulent cervicitis or chlamydial infection or gonorrhoea b) Other STIs (excluding HIV and hepatitis) c) Vaginitis (including <i>Trichomonas vaginalis</i> and bacterial vaginosis) d) Increased risk of STIs	D A A A	Clarification: If no symptoms persist following treatment, sterilization may be performed.
HIV/AIDS		
HIGH RISK OF HIV	A	Clarification: No routine screening is needed. Appropriate infection prevention procedures, including universal precautions, must be carefully observed with all surgical procedures. The use of condoms is recommended following sterilization.
ASYMPTOMATIC OR MILD HIV CLINICAL DISEASE (WHO STAGE 1 OR 2)	A	Clarification: No routine screening is needed. Appropriate infection prevention procedures, including universal precautions, must be carefully observed with all surgical procedures. The use of condoms is recommended following sterilization.
SEVERE OR ADVANCED HIV CLINICAL DISEASE (WHO STAGE 3 OR 4)	S	Clarification: The presence of an AIDS-related illness may require that the procedure be delayed.
OTHER INFECTIONS		
SCHISTOSOMIASIS a) Uncomplicated b) Fibrosis of the liver (if severe, see cirrhosis)	A C	Clarification: Liver function may need to be evaluated.

FEMALE SURGICAL STERILIZATION		
Sterilization does not protect against sexually transmitted infections (STIs), including HIV. If there is a risk of STI/HIV, the correct and consistent use of condoms is recommended. When used correctly and consistently, condoms offer one of the most effective methods of protection against STIs, including HIV. Female condoms are effective and safe, but are not used as widely by national programmes as male condoms		
CONDITION * additional comments after this table	CATEGORY ^a A = accept, C = caution, D = delay, S = special	CLARIFICATIONS/EVIDENCE
TUBERCULOSIS		
a) Non-pelvic	A	
b) Pelvic	S	
MALARIA		
	A	
ENDOCRINE CONDITIONS		
DIABETES*		
a) History of gestational disease	A	Clarification: If blood glucose is not well controlled, referral to a higher-level facility is recommended. Clarification: There is a possible decrease in healing and an increased risk of wound infection. Use of prophylactic antibiotics is recommended. Evidence: Diabetic women were more likely to have complications when undergoing sterilization (20).
b) Non-vascular disease		
i) non-insulin-dependent	C	
ii) insulin-dependent	C	
c) Nephropathy/retinopathy/neuropathy	S	
d) Other vascular disease or diabetes of > 20 years' duration	S	
THYROID DISORDERS*		
a) Simple goitre	A	
b) Hyperthyroid	S	
c) Hypothyroid	C	
GASTROINTESTINAL CONDITIONS		
GALL BLADDER DISEASE		
a) Symptomatic		
i) treated by cholecystectomy	A	
ii) medically treated	A	
iii) current	D	
b) Asymptomatic	A	
HISTORY OF CHOLESTASIS		
a) Pregnancy related	A	
b) Past-COC related	A	

FEMALE SURGICAL STERILIZATION		
Sterilization does not protect against sexually transmitted infections (STIs), including HIV. If there is a risk of STI/HIV, the correct and consistent use of condoms is recommended. When used correctly and consistently, condoms offer one of the most effective methods of protection against STIs, including HIV. Female condoms are effective and safe, but are not used as widely by national programmes as male condoms.		
CONDITION * additional comments after this table	CATEGORY ^a A = accept, C = caution, D = delay, S = special	CLARIFICATIONS/EVIDENCE
VIRAL HEPATITIS*		Clarification: Appropriate infection-prevention procedures, including universal precautions, must be carefully observed with all surgical procedures.
a) Acute or flare	D	
b) Carrier	A	
c) Chronic	A	
CIRRHOSIS		Clarification: Liver function and clotting might be altered. Liver function should be evaluated.
a) Mild (compensated)	A	
b) Severe (decompensated)	S	
LIVER TUMOURS		Clarification: Liver function and clotting might be altered. Liver function should be evaluated.
a) Benign		
i) focal nodular hyperplasia	A	
ii) hepatocellular adenoma	C	
b) Malignant (hepatoma)	C	
ANAEMIAS		
THALASSAEMIA	C	
SICKLE CELL DISEASE*	C	
IRON-DEFICIENCY ANAEMIA		Clarification: The underlying disease should be identified. Both preoperative haemoglobin (Hb) level and operative blood loss are important factors in women with anaemia. If peripheral perfusion is inadequate, this may decrease wound healing.
a) Hb < 7 g/dl	D	
a) Hb ≥ 7 to < 10 g/dl	C	
OTHER CONDITIONS RELEVANT ONLY FOR FEMALE SURGICAL STERILIZATION		
LOCAL INFECTION	D	Clarification: There is an increased risk of postoperative infection.
COAGULATION DISORDERS*	S	
RESPIRATORY DISEASES		Clarification: The procedure should be delayed until the condition is corrected. There are increases in anaesthesia-related and other perioperative risks.
a) Acute (bronchitis, pneumonia)	D	
b) Chronic		
i) asthma	S	
ii) bronchitis	S	
iii) emphysema	S	
iv) lung infection	S	

FEMALE SURGICAL STERILIZATION		
Sterilization does not protect against sexually transmitted infections (STIs), including HIV. If there is a risk of STI/HIV, the correct and consistent use of condoms is recommended. When used correctly and consistently, condoms offer one of the most effective methods of protection against STIs, including HIV. Female condoms are effective and safe, but are not used as widely by national programmes as male condoms.		
CONDITION * additional comments after this table	CATEGORY ^a A = accept, C = caution, D = delay, S = special	CLARIFICATIONS/EVIDENCE
SYSTEMIC INFECTION OR GASTROENTERITIS*	D	
FIXED UTERUS DUE TO PREVIOUS SURGERY OR INFECTION*	S	
ABDOMINAL WALL OR UMBILICAL HERNIA	S	Clarification: Hernia repair and tubal sterilization should be performed concurrently if possible.
DIAPHRAGMATIC HERNIA*	C	
KIDNEY DISEASE*	C	
SEVERE NUTRITIONAL DEFICIENCIES*	C	
PREVIOUS ABDOMINAL OR PELVIC SURGERY	C	Evidence: Women with previous abdominal or pelvic surgery were more likely to have complications when undergoing sterilization (20, 22, 43–45).
STERILIZATION CONCURRENT WITH ABDOMINAL SURGERY		
a) Elective	C	
b) Emergency (without previous counselling)	D	
c) Infectious condition	D	
STERILIZATION CONCURRENT WITH CAESAREAN SECTION*	A	

^a Further explanation of A, C, D and S categories:

A = **accept:** There is no medical reason to deny sterilization to a person with this condition.

C = **caution:** The procedure is normally conducted in a routine setting, but with extra preparation and precautions.

D = **delay:** The procedure is delayed until the condition is evaluated and/or corrected. Alternative temporary methods of contraception should be provided.

S = **special:** The procedure should be undertaken in a setting with an experienced surgeon and staff, equipment needed to provide general anaesthesia, and other back-up medical support. For these conditions, the capacity to decide on the most appropriate procedure and anaesthesia regimen is also needed. Alternative temporary methods of contraception should be provided if referral is required or there is otherwise any delay.

MALE SURGICAL STERILIZATION		
Sterilization does not protect against sexually transmitted infections (STIs), including HIV. If there is a risk of STI/HIV, the correct and consistent use of condoms is recommended. When used correctly and consistently, condoms offer one of the most effective methods of protection against STIs, including HIV. Female condoms are effective and safe, but are not used as widely by national programmes as male condoms		
CONDITION * additional comments after this table	CATEGORY ^a A = accept, C = caution, D = delay, S = special	CLARIFICATIONS/EVIDENCE
PERSONAL CHARACTERISTICS AND REPRODUCTIVE HISTORY		
YOUNG AGE	C	Clarification: Young men, like all men, should be counselled about the permanency of sterilization and the availability of alternative, long-term, highly effective methods. Evidence: Men who underwent vasectomy at young ages were more likely to have the procedure reversed than those who underwent vasectomy at older ages (2).
DEPRESSIVE DISORDERS		
DEPRESSIVE DISORDERS	C	
HIV/AIDS		
HIGH RISK OF HIV	A	Clarification: No routine screening is needed. Appropriate infection prevention procedures, including universal precautions, must be carefully observed with all surgical procedures. The use of condoms is recommended following sterilization.
ASYMPTOMATIC OR MILD HIV CLINICAL DISEASE (WHO STAGE 1 OR 2)	A	Clarification: No routine screening is needed. Appropriate infection prevention procedures, including universal precautions, must be carefully observed with all surgical procedures. The use of condoms is recommended following sterilization.
SEVERE OR ADVANCED HIV CLINICAL DISEASE (WHO STAGE 3 OR 4)	S	Clarification: The presence of severe or advanced HIV clinical disease may require that the procedure be delayed.
ENDOCRINE CONDITIONS		
DIABETES*	C	Clarification: If blood glucose is not well controlled, referral to a higher-level facility is recommended.
ANAEMIAS		
SICKLE CELL DISEASE*	A	
OTHER CONDITIONS RELEVANT ONLY FOR MALE SURGICAL STERILIZATION		
LOCAL INFECTION*		
a) Scrotal skin infection	D	
b) Active STI	D	
c) Balanitis	D	
d) Epididymitis or orchitis	D	

MALE SURGICAL STERILIZATION

Sterilization does not protect against sexually transmitted infections (STIs), including HIV. If there is a risk of STI/HIV, the correct and consistent use of condoms is recommended. When used correctly and consistently, condoms offer one of the most effective methods of protection against STIs, including HIV. Female condoms are effective and safe, but are not used as widely by national programmes as male condoms

CONDITION * additional comments after this table	CATEGORY ^a A = accept, C = caution, D = delay, S = special	CLARIFICATIONS/EVIDENCE
COAGULATION DISORDERS*	S	
PREVIOUS SCROTAL INJURY	C	
SYSTEMIC INFECTION OR GASTROENTERITIS*	D	
LARGE VARICOCELE*	C	
LARGE HYDROOCELE*	C	
FILIARIASIS; ELEPHANTIASIS*	D	
INTRASCROTAL MASS*	D	
CRYPTORCHIDISM	S	
INGUINAL HERNIA*	S	

^a Further explanation of A, C, D and S categories:

A = **accept**: There is no medical reason to deny sterilization to a person with this condition.

C = **caution**: The procedure is normally conducted in a routine setting, but with extra preparation and precautions.

D = **delay**: The procedure is delayed until the condition is evaluated and/or corrected. Alternative temporary methods of contraception should be provided.

S = **special**: The procedure should be undertaken in a setting with an experienced surgeon and staff, equipment needed to provide general anaesthesia, and other back-up medical support. For these conditions, the capacity to decide on the most appropriate procedure and anaesthesia regimen is also needed. Alternative temporary methods of contraception should be provided if referral is required or there is otherwise any delay.

Conditions relating to Male and Female condoms, Spermicides, diaphragms, cervical caps, and the lactational amenorrhoea Method.

All other conditions listed on the previous pages that do not appear here are a category 1 or NA for male and female condoms, spermicides, diaphragms, and cervical caps and not listed in the Medical Eligibility Criteria for the lactational amenorrhoea method.

Table 5-5. Eligibility Criteria for Use of Barrier Methods, Spermicides, and the Lactational Amenorrhoea Method³

Condition	Male and female condoms	Spermicides	diaphragms	cervical cPS	lactational amenorrhoea method
reproductive History					
Parity					
Nulliparous (has not given birth)	1	1	1	1	—
Parous (has given birth)	1	1	2	2	—
< 6 weeks postpartum	1	1	Na ^v	Na ^v	—
cardiovascular disease					
complicated valvular heart disease (pulmonary hypertension, risk of atrial fibrillation, history of subacute bacterial endocarditis) [§]	1	1	2	2	—
reproductive tract infections and disorders					
cervical intraepithelial neoplasia	1	1	1	4	—
cervical cancer	1	2	1	4	—
anatomical abnormalities	1	1	Na ^w	Na ^x	—
HiV/aids[§]					
High risk of HiV	1	4	4	4	—
HiV-infected	1	3	3	3	C ^y
aids	1	3	3	3	C ^y
Others					
History of toxic shock syndrome	1	1	3	3	—
Urinary tract infection	1	1	2	2	—
	3	1	3	3	

v Wait to fit/use until uterine involution is complete.

w Diaphragm cannot be used in certain cases of uterine prolapse.

x Cap use is not appropriate for a client with severely distorted cervical anatomy.

y Women with HIV or AIDS should avoid breastfeeding if replacement feeding is affordable, feasible, acceptable, sustainable, and safe. Otherwise, exclusive breastfeeding is recommended during the first 6 months of a baby's life and should then be discontinued over a period of 2 days to 3 weeks.

z Does not apply to plastic condoms, diaphragms, and cervical caps.

Additional conditions relating to lactational amenorrhoea Method

Medication used during breastfeeding: To protect infant health, breastfeeding is not recommended for women using such drugs as anti-metabolites, bromocriptine, certain anticoagulants, corticosteroids (high doses), cyclosporine, ergotamine, lithium, mood altering drugs, radioactive drugs, and reserpine.

Conditions affecting the newborn that may make breastfeeding difficult: Congenital deformities of the mouth, jaw, or palate; newborns who are small-for-date or premature and needing intensive neonatal care; and certain metabolic disorders.

Table 5-6. Eligibility Criteria for Use of Symptoms- and Calendar-Based Methods³

	Symptoms-based methods	calendar-based methods
a = accept c = caution d = delay		
age: post menarche or perimenopause	c	c
breastfeeding < 6 weeks postpartum	d	d ^{aa}
breastfeeding = 6 weeks postpartum	c	d ^{bb}
Postpartum, not breastfeeding	d ^{cc}	d ^{aa}
Postabortion	c	d ^{dd}
irregular vaginal bleeding	d	d
Vaginal discharge	d	a
taking drugs that affect cycle regularity, hormones, and/or fertility signs	d/c ^{ee}	d/c ^{ee}
Diseases that elevate body temperature		
Acute	d	a
Chronic	c	a

- aa Delay until she has had 3 regular menstrual cycles.
- bb Use caution after monthly bleeding or normal secretions return (usually at least 6 weeks after childbirth).
- cc Delay until monthly bleeding or normal secretions return (usually < 4 weeks postpartum).
- dd Delay until she has had one regular menstrual cycle.
- ee Delay until the drug's effect has been determined, then use caution.

6

NATURAL METHODS

Introduction

Natural Family Planning (NFP) refers to a variety of methods used to plan or prevent pregnancy, based on identifying the woman's fertile days. For all natural methods, avoiding unprotected intercourse during the fertile days is what prevents pregnancy. Natural methods are also known as fertility awareness-based methods.

There are 6 days during the menstrual cycle when it is possible for a woman to become pregnant. This is because of the life span of the sperm, which remain viable in the woman's reproductive tract for up to 5 days, and the fact that the ovum can be fertilized for up to 24 hours following ovulation. This fertility period might change with few days depending on when ovulation actually occurs.

The effectiveness and significant advantages of NFP address the needs of diverse populations with varied religious and ethical beliefs. They also provide an alternative for women who want to use natural methods for medical or personal reasons.

The most common natural methods used are:

- Lactational amenorrhoea method (LAM or breastfeeding)
- Fertility awareness-based methods:
 - Calendar methods:
 - Calendar-based method
 - Standard Days Method® (SDM)
 - Symptoms-based methods:
 - Ovulation method/cervical mucus method
 - Two Day Method®
 - Basal body temperature (BBT) method
 - Sympto thermal method/multiple indicator method
 - Withdrawal method

Policy/Standard

- Natural methods should be offered to all potential clients as a choice during counselling.
- All service providers should be well-trained in counselling and techniques of natural methods.

Lactational Amenorrhoea Method (LAM) Family Planning Method Based on Breastfeeding

In developing nations, including Pakistan, breastfeeding plays a major role in prolonging birth intervals and thereby reducing the fertility rate. LAM is a temporary family planning (FP) method based on the natural effect of breastfeeding on fertility. ("Lactational" means related to breastfeeding. "Amenorrhoea" means not having monthly bleeding.)

The Bellagio Consensus provided the scientific basis for defining the conditions under which breastfeeding can be used safely and effectively for birth-spacing purposes, and programmatic guidelines were developed for the use of the LAM in family planning. These guidelines include the following three criteria, all of which must be met to ensure adequate protection from an unplanned pregnancy:

- amenorrhoea
- fully or nearly fully breastfeeding
- less than six months postpartum.

"Fully breastfeeding" includes both exclusive breastfeeding (the infant receives no other liquid or food, not even water, in addition to breast milk)

"Nearly fully breastfeeding" means that the infant receives some liquid or food in addition to breast milk, but the majority of feedings (more than three-fourths of all feeds) are breast milk.

Mode of Action

LAM works primarily by preventing the release of eggs from the ovaries (ovulation). Frequent breastfeeding temporarily prevents the release of the natural hormones that cause ovulation.

Effectiveness

Effectiveness depends on the user: Risk of pregnancy is greatest when a woman cannot fully breastfeed her infant.

- When used correctly, there is less than 1 pregnancy per 100 women using LAM in the first 6 months after childbirth.
- As commonly used, there are about 2 pregnancies per 100 women using LAM in the first 6 months after childbirth. This means that 98 of every 100 women relying on LAM will not become pregnant.

Return of fertility after LAM is delayed Depends on how much the woman continues to breastfeed.

Protection against sexually transmitted infections (STIs): None.

Advantages

- Effectively prevents pregnancy for at least 6 months.
- Can be used immediately after childbirth.
- No need to do anything at time of sexual intercourse.
- No direct cost for FP or for feeding the baby.
- No supplies or procedures needed to prevent pregnancy.
- No hormonal side effects.
- A breastfeeding woman can use LAM to space her next birth and as a transition to another contraceptive method.
- Breastfeeding practices required by LAM have other health benefits for baby and mother, including:
 - Provides the healthiest food for the baby
 - Helps protect the baby from life-threatening diseases such as diarrhoea, measles, and pneumonia by passing the mother's immunities to the baby.
 - Helps develop a close relationship between mother and baby.
 - Helps early involution of uterus.
 - Prevents breast engorgement.
 - Provide protection against breast cancer.

Limitations

- Effectiveness after 6 months is not certain.
- Frequent breastfeeding may be inconvenient or difficult for some women, especially working mothers.
- No protection against STIs, including HIV/AIDS.

Client Assessment as per World Health Organization (WHO) Medical Eligibility Criteria

- The lactational amenorrhoea method (LAM) does not protect against sexually transmitted infections (STIs), including HIV. If there is a risk of STI/HIV, the correct and consistent use of condoms is recommended. When used correctly and consistently, condoms offer one of the most effective methods of protection against STIs, including HIV. Female condoms are effective and safe, but are not used as widely by national programmes as male condoms.

- Her newborn has a condition that makes it difficult to breastfeed (including being small-for-date or premature and needing intensive neonatal care, being unable to digest food normally, or having deformities of the mouth, jaw, or palate).
- The main indications for breastfeeding remain the need to provide an ideal food for the infant and to protect it against disease. There are no medical conditions in which the use of the LAM is restricted and there is no documented evidence of its negative impact on maternal health. However, certain conditions or obstacles which affect breastfeeding may also affect the duration of amenorrhoea, making this a less useful choice for family planning purposes. These include:

■ Women with HIV positive clinical and nonclinical disease

- Breastfeeding should be promoted, protected and supported in all populations, for all women who are HIV-negative or of unknown HIV status. A woman living with HIV, however, can transmit the virus to her child through breastfeeding. Yet breastfeeding, and especially early and exclusive breastfeeding, is one of the most critical factors for improving child survival. Breastfeeding also confers many other benefits in addition to reducing the risk of death.
- There is now strong evidence that giving antiretroviral medications (ARVs) to either the HIV-positive mother or the HIV-exposed infant or both can significantly reduce the risk of transmitting HIV through breastfeeding.¹⁵ This transforms the landscape in which decisions should be made by national health authorities and individual mothers. In the presence of ARVs - either lifelong antiretroviral therapy (ART) to the mother or other ARV interventions to the mother or infant - the infant can receive all the benefits of breastfeeding with little risk of acquiring HIV. In some well-resourced countries with low infant and child mortality rates, avoidance of all breastfeeding will still be appropriate.
(Further information: <http://www.who.int/hiv/topics/mtct>)
- Mothers living with HIV should receive the appropriate ARV interventions and should exclusively breastfeed their infants for the first six months of life, introducing appropriate complementary foods thereafter, and should continue breastfeeding their infants for the first 12 months of life. Breastfeeding should then only stop once a nutritionally adequate and safe diet without breast-milk can be provided. When mothers decide to stop breastfeeding, they should stop gradually within one month and infants should be provided with safe and adequate replacement feeds to enable normal growth and development.

■ If the infant is HIV-negative or of unknown HIV status:

A mother known to be living with HIV should only give commercial infant formula milk as a replacement feed to this infant when all of the following specific conditions are met:

- Safe water and sanitation are assured at the household level and in the community, and
- The mother or other caregiver can reliably provide sufficient infant formula milk to support normal growth and development of the infant, and

- The mother or caregiver can prepare it cleanly and frequently enough so that it is safe and carries a low risk of diarrhea and malnutrition, and
- The mother or caregiver can, in the first six months, exclusively give infant formula milk, and
- The family is supportive of this practice, and
- The mother or caregiver can access health care that offers comprehensive child health services.

■ **If the infant is known to be HIV-positive:**

The mother is strongly encouraged to exclusively breastfeed for the first six months of the infant's life and to continue breastfeeding as per the recommendations for the general population, that is up to two years or beyond.

Women who are living with HIV should receive skilled counselling to help them. They should also have access to follow-up care and support, including family planning and nutritional support.

■ **Medication used during breastfeeding**

In order to protect infant health, breastfeeding is not recommended for women using such drugs as: anti-metabolites, bromocriptine, certain anticoagulants, corticosteroids (high doses), ciclosporin, ergotamine, lithium, mood-altering drugs, radioactive drugs and reserpine.

■ **Conditions affecting the newborn**

Congenital deformities of the mouth, jaw or palate; newborns who are small-for-date or premature and needing intensive neonatal care; and certain metabolic disorders of the infant can all make breastfeeding difficult.

LAM can also be used in any circumstances by women with the following characteristics or health conditions:

- Smoke cigarettes, Huqqa or Shisha
- Iron deficiency anaemia
- Fat or thin
- Malaria
- Young or old
- Sickle cell disease
- Benign breast disease
- Gall bladder disease
- Thyroid disease
- Headaches
- Uterine fibroid
- High blood pressure
- Valvular heart disease
- Varicose veins
- Diabetes

The only conditions that limit use of LAM are conditions that make breastfeeding difficult or that rule out breastfeeding.

How to Use the Method

Starting Time

Start breastfeeding as soon as possible (within 1 hour) after the baby is born.



Source: Georgetown University, Institute for Reproductive Health, and Jhpiego. 2009. Lactational Amenorrhea Method (LAM): A Learning Resource Package for Family Planning Service Providers and Trainers. Georgetown University: Washington, D.C.

Technique

- An ideal pattern is feeding on demand (that is, whenever the baby wants to be fed) and at least 10–12 times in 24 hours in the first few weeks after childbirth and thereafter 8–10 times in 24 hours, including at least once at night in the first months.
- Daytime feedings should be no more than 4 hours apart, and nighttime feedings no more than 6 hours apart.
- Some babies may not want to breastfeed 8–10 times a day and may want to sleep through the night. These babies may need gentle encouragement to breastfeed more often.

The mother should start giving other foods in addition to breast milk when the baby is 6 months old. At this age, breast milk can no longer fully nourish a growing baby.

Time to Start Another FP Method: Start Another Method When:

- Menstrual periods return (bleeding in the first 56 days, or 8 weeks, after childbirth is not considered menstrual bleeding), or
- Baby is 6 months old (about the time the baby starts sitting up), or
- The woman stops fully breastfeeding,
- The woman no longer wants to use LAM for FP.

Follow-Up Visit

Plan for the next visit while the LAM criteria still apply, so that the woman can choose another method and continue to be protected from pregnancy.

She can be given another method of her choice if required, offer her condoms or progestin-only pills. She can start to use them if the baby is no longer fully breastfeeding, if her monthly bleeding returns, or if the baby reaches 6 months of age before she can come back for another method. Emergency contraceptive pills (ECPs) are another option, particularly for unprotected sex. Plan for a follow-on method. Give her any supplies now.

Supporting the User

If the client reports any problems with using LAM:

- Do not dismiss the woman's concerns and reassure her.
- Give help and advice about breastfeeding technique, and encourage continuing breastfeeding.
- If the woman is not satisfied with LAM after counselling and discussion, help her to choose another method.

Table 6-1. Lactational Amenorrhoea Method: Side Effects and Their Management

Side Effects	Management
Baby is not getting enough milk	<p>Reassure the woman that most women can produce enough breast milk to feed their babies. She should increase her fluid intake and balanced diet.</p> <p>If the newborn is gaining more than 500 gm a month, weighs more than birth weight at 2 weeks, or urinates at least 6 times a day, reassure her that her baby is getting enough breast milk.</p> <p>Tell her to breastfeed her newborn about every 2 hours to increase milk supply.</p> <p>Recommend that she reduce any supplemental foods and/or liquids if the baby is less than 6 months of age.</p>

Side Effects	Management
Sore breasts	<p>If her breasts are full and painful/tender, she may have engorged breasts. If one breast has tender/painful lumps, she may have blocked ducts. Engorged breasts or blocked ducts may progress to red and tender, infected breasts. Treat infected breasts with antibiotics according to clinical guidelines. To aid healing, advise her to:</p> <ul style="list-style-type: none"> • Continue to breastfeed often. • Massage her breasts before and during breastfeeding. • Apply heat or a warm compress to breasts. • Try different breastfeeding positions. • Ensure that the infant latches properly to the breast. • Express some milk before breastfeeding.
Sore or cracked nipples	<p>If her nipples are cracked, she can continue breastfeeding. Assure her that they will heal over time. To aid healing, advise her to:</p> <ul style="list-style-type: none"> • Apply drops of breast milk to the nipples after breastfeeding and allow them to air dry. • After feeding, use a finger to break suction first before removing the baby from the breast. • Do not wait until the breast is full to breastfeed. If full, express some milk first. <p>Teach the woman about proper attachment and how to check for signs that the baby is not attaching properly. Tell her to clean her nipples with water only, once a day, and to avoid soaps and alcohol-based solutions. Examine her nipples and the baby's mouth and buttocks for signs of fungal infection (thrush).</p>

Counseling for Breastfeeding

Explain the benefits of breastfeeding as the source of nutrition for the baby and a natural method of contraception. Ask the client if she is having any difficulty in breastfeeding and advise her as needed.

Encourage the woman to continue breastfeeding her baby for as long as possible. She will need another method when:

- Her menstrual periods return;
- The baby becomes 6 months old; or
- The baby is not taking breast milk as frequently as before (more than 6 hours between feedings), or the baby is taking food or liquid as substitutes for breast milk feeds.

After explaining the instructions, ask the client to repeat them.

Contraception for Non-Lactating Mothers

Most non-lactating women resume menses within 4–6 weeks of delivery. Ovulation generally occurs and the client can again become pregnant. Ovulation can return at any time, even before menstruation. However, this period is unpredictable, and an FP method should be used to ensure that pregnancy does not occur and the client can again become pregnant.

Suitable Methods of Contraception during Lactation

The most appropriate methods of contraception for lactating mothers are those that do not influence the quantity and quality of breast milk, are not excreted in breast milk in amounts that make it unsafe for the infant, are effective and safe for the mother, are easily available, and are convenient to use.

Counsel the client about the methods that can be used, and assist her in making a choice. Give the following information about contraceptives that can and cannot be used during the lactation period:

- Combined oral contraceptive pills are not suitable during the first 6 months of lactation.
- The IUCD (CuT or Multiload) can be inserted 4 weeks after delivery. In facilities where there are trained providers, the CuT IUCD can be inserted within 10 minutes after delivery of the placenta or during the first 48 hours after delivery of the baby.
- Mini-pills (progestin-only) can be started immediately after postpartum.
- Implants can be used as soon as in immediate postpartum period and onwards.
- Progestin injectable contraceptives can be given after 6 weeks postpartum.
- Condoms can safely be used at any time.

Tubal ligation can be performed if the client does not want any more children. It can be performed within 1 week after delivery, or at any time 6 or more weeks after delivery as an interval procedure.

Fertility Awareness-Based Methods

Fertility awareness means that a woman learns how to detect when the fertile time of her menstrual cycle begins and ends (ovulation days).

Women can use several ways to calculate the fertile time:

- Calendar-based methods (SDM, calendar rhythm method)
- Symptoms-based methods (ovulation method/cervical mucus, TwoDay Method, BBT method, symptothermal method/multiple indicator method, cervical mucous observation)

Mode of Action

Fertility awareness helps a couple know when the woman can become pregnant. The couple avoids pregnancy by changing their sexual behaviour during fertile days. They can practice:

- Periodic abstinence-avoiding intercourse completely during the fertile time. This method is also called Natural Family Planning (NFP).

Effectiveness

Effective or very effective when used consistently and correctly; effectiveness ranges from 91-99 percent for various methods.

Only somewhat effective as commonly used: 25 pregnancies occur per 100 women in the first year of use (1 in every 4).

Advantages

- Once the method is understood, can be used to avoid pregnancy or to become pregnant, according to the couple's wishes.
- No physical side effects.
- No cost.
- Can be used by most couples if they are committed to it.
- Effective if used correctly and consistently.
- Immediately reversible.
- No effect on breastfeeding or breast milk.
- No hormonal side effects.
- Involves men in FP.
- Educates couple about women's fertility cycles.

Limitations

- Effectiveness depends on correct usage.
- Takes time to learn how to identify fertile time accurately. For a calendar method, a menstrual record of at least 6 months is required.
- Abstinence during fertile days may be difficult for some couples.
- Will not work without continuing cooperation and commitment of the couple.
- Can become unreliable or hard to use in conditions like fever due to infection, or when menstrual cycle length is short or long.
- After childbirth, may be hard to identify the fertile time until the menstrual cycle becomes regular again.
- Calendar method may not be effective for women with irregular menstrual cycles.
- Most methods require women or couples to keep careful daily records and pay close attention to body changes.
- Does not protect against STIs including HIV/AIDS.
- If client has or might get an STI, convince her to use condoms regularly. Give her condoms.

Method of Use

Starting Time

Once trained, a woman or couple can begin using fertility awareness-based techniques at any time. Before starting the fertility awareness-based methods, a woman must record the length of her menstrual cycles for at least 6 months.

Fertility awareness-based methods can be used in any circumstances by women with any of the following characteristics or health conditions:

- Smoke cigarettes
- High blood pressure
- Deep vein thrombosis or pulmonary embolism
- Varicose veins
- Mild or severe headaches
- Painful menstruation
- Uterine fibroids
- Endometriosis
- Ovarian cysts
- Iron deficiency anaemia
- Viral hepatitis
- Malaria

Additional Comments

Breastfeeding

Fertility awareness-based (FAB) methods during breastfeeding may be less effective than when not breastfeeding.

< 6 weeks postpartum: Women who are exclusively breastfeeding and are amenorrhoeic are unlikely to have sufficient ovarian function to produce detectable fertility signs and hormonal changes during the first six weeks postpartum. However, the likelihood of resumption of fertility increases with time postpartum and with substitution of breast-milk by other foods.

After menses begin: When the woman notices fertility signs (particularly cervical secretions), she can use a symptoms-based method. First postpartum menstrual cycles in breastfeeding women vary significantly in length. It takes several cycles for the return to regularity. When she has had at least three postpartum menses and her cycles are regular again, she can use the Calendar Rhythm Method. When she has had at least four postpartum menses and her most recent cycle was 26-32 days long, she can use the Standard Days Method. Prior to that time, a barrier method should be offered if the woman plans to use a FAB method later.

Postpartum

< 4 weeks: Non-breastfeeding women are not likely to have sufficient ovarian function to either require a FAB method or have detectable fertility signs or hormonal changes prior to four weeks postpartum. Although the risk of pregnancy is low, a method that is appropriate for the postpartum period should be offered.

≤ 4 weeks: Non-breastfeeding women are likely to have sufficient ovarian function to produce detectable fertility signs and/or hormonal changes at this time; the likelihood increases rapidly with time postpartum. A woman can use calendar-based methods as soon as she has completed at least three postpartum menses and her cycles are regular again. A woman can use the Standard Days Method when she has had at least four postpartum menses and her most recent cycle was 26-32 days long. Methods appropriate for the postpartum period should be offered prior to that time.

Post-abortion

Post-abortion women are likely to have sufficient ovarian function to produce fertility signs and/or hormonal changes; the likelihood increases with time post-abortion. A woman can start using calendar-based methods after she has had at least one post-abortion menses; if most of her cycles prior to this pregnancy were 26-32 days long, she can use the Standard Days Method. Methods appropriate for the post-abortion period should be offered prior to that time.

Calendar-Based Methods

All women can use calendar-based methods. No medical conditions prevent the use of these methods, but some conditions can make them more difficult to use effectively.

Caution means that additional or special counselling may be needed to ensure correct use of the method.

Delay means that use of a particular fertility awareness method should be delayed until the condition is evaluated or corrected. Give the client another method to use until she can start the calendar-based method.

In the following situations, use caution with calendar-based methods:

- Menstrual cycles have just started or have become less frequent or stopped due to older age. (Menstrual cycle irregularities are common in young women in the first several years after their first monthly bleeding and in older women who are approaching menopause. Identifying the fertile time may be difficult.)

In the following situations, delay starting calendar-based methods:

- Recently gave birth or is breastfeeding. (Delay until she has had at least three menstrual cycles and her cycles are regular again.)
- Recently had an abortion or miscarriage. (Delay until the start of her next monthly bleeding.)

- Irregular vaginal bleeding.

In the following situations, delay or use caution with calendar-based methods:

- Taking any mood-altering drugs such as anti-anxiety therapies (except benzodiazepines), antidepressants (selective serotonin reuptake inhibitors [SSRIs], tricyclic or tetracyclic), long-term use of certain antibiotics, or long-term use of any nonsteroidal anti-inflammatory drug (such as aspirin or ibuprofen). These drugs may affect timing of ovulation.

Providing Calendar-Based Methods

When to Start

Once trained, a woman or couple usually can begin using calendar-based methods at any time. Clients who cannot start immediately another method to use until they can start.

Table 6-2. When to Start Calendar-Based Methods

Woman's Situation	When to Start
Having regular menstrual cycles	Any time of the month No need to wait until the start of next monthly bleeding.
No monthly bleeding	Delay calendar-based methods until monthly bleeding returns.
After childbirth (whether or not breastfeeding)	Delay the Standard Days Method until she has had three menstrual cycles and the last one was 26-32 days long. Regular cycles will return later in breastfeeding women than in women who are not breastfeeding.
After miscarriage or abortion	Delay the Standard Days Method until the start of her next monthly bleeding, when she can start if she has no bleeding due to injury to the genital tract.
Switching from a hormonal method	Delay starting the Standard Days Method until the start of her next monthly bleeding. If she is switching from injectables, delay the Standard Days Method at least until her repeat injection would have been given, and then start it at the beginning of her next monthly bleeding.
After taking emergency contraceptive pills	Delay the Standard Days Method until the start of her next monthly bleeding.

Explaining How to Use Calendar-Based Methods

Standard Days Method

IMPORTANT: A woman can use the Standard Days Method if most of her menstrual cycles are 26–32 days long.

If she has more than two longer (>32 days) or shorter (<26 days) cycles within a year, the Standard Days Method will be less effective and she should choose another method.



Table 6-3. How to Use Calendar-Based Methods

Basic Principles of the Method	How to Use the Method
Keep track of the days of the menstrual cycle	A woman keeps track of the days of her menstrual cycle, counting the first day of monthly bleeding as day 1.
Avoid unprotected sex from days 8-19	<p>Days 8-19 of every cycle are considered fertile days for all users of the Standard Days Method.</p> <p>The couple avoids vaginal sex or uses condoms or a diaphragm during days 8-19. They can also use withdrawal or spermicides, but these are less effective.</p> <p>The couple can have unprotected sex on all the other days of the cycle—days 1-7 at the beginning of the cycle and from day 20 until her next monthly bleeding begins.</p>
Use memory aids if needed	The couple can use CycleBeads, a colour-coded string of beads that indicates fertile and non-fertile days of a cycle, or they can mark a calendar or use some other memory aid.

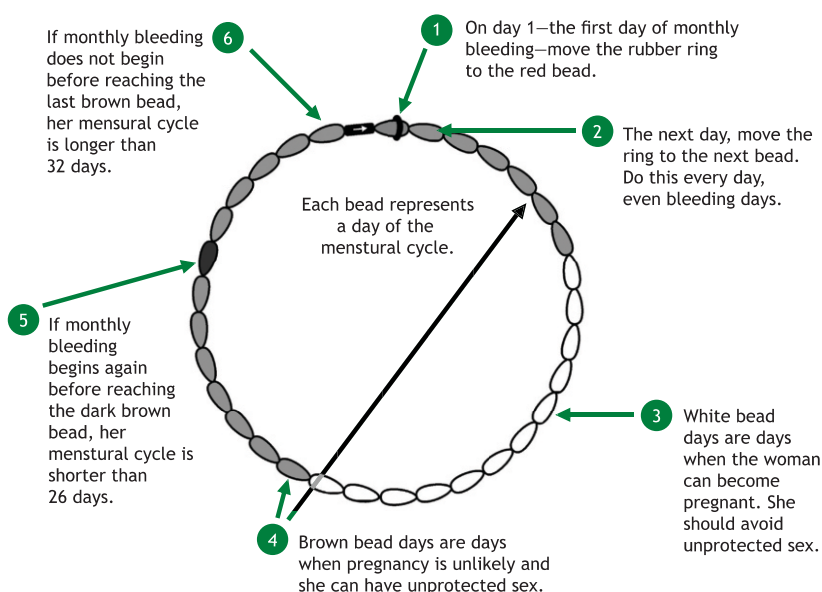

Calendar Rhythm Method

Basic Principles of the Method	How to Use the Method
Keep track of the days of the menstrual cycle	Before relying on this method, a woman records the number of days in each menstrual cycle for at least 6 months. The first day of monthly bleeding is always counted as day 1.
Estimate the fertile time	The woman subtracts 18 from the length of her shortest recorded cycle. This tells her the estimated first day of her fertile time. Then she subtracts 11 days from the length of her longest recorded cycle. This tells her the estimated last day of her fertile time.
Avoid unprotected sex during fertile time	The couple avoids vaginal sex, or uses condoms or a diaphragm, during the fertile time. They can also use withdrawal or spermicides, but these are less effective.
Update calculations monthly	<p>She updates these calculations each month, always using the 6 most recent cycles.</p> <p>Example:</p> <ul style="list-style-type: none"> • If the shortest of her last six cycles was 27 days, $27 - 18 = 9$, she starts avoiding unprotected sex from day 9. • If the longest of her last six cycles was 31 days, $31 - 11 = 20$, she can have unprotected sex again from day 21. • Thus, she must avoid unprotected sex from day 9 through day 20 of her cycle.

Symptoms-Based Methods

All women can use symptoms-based methods. No medical conditions prevent the use of these methods, but some conditions can make them more difficult to use effectively.

Caution means that additional or special counselling may be needed to ensure correct use of the method.

Delay means that use of a particular fertility awareness method should be delayed until the condition is evaluated or corrected. Give the client another method to use until she can start the symptoms-based method.

In the following situations, use caution with symptoms-based methods:

- Recently had an abortion or miscarriage.
- Menstrual cycles have just started or have become less frequent or stopped due to older age. (Menstrual cycle irregularities are common in young women in the first several years after their first monthly bleeding and in older women who are approaching menopause. Identifying the fertile time may be difficult.)
- Has a chronic condition that raises her body temperature (for BBT and symptothermal methods).

In the following situations, delay starting symptoms-based methods:

- Recently gave birth or is breastfeeding. (Delay until normal vaginal secretions have returned—usually at least 6 months after childbirth for breastfeeding women and at least 4 weeks after childbirth for women who are not breastfeeding. For several months after regular cycles have returned, use with caution.)
- An acute condition that raises her body temperature (for basal body temperature and symptothermal methods).
- Irregular vaginal bleeding.
- Abnormal vaginal discharge.

In the following situations, delay or use caution with symptoms-based methods:

- Taking any mood-altering drugs such as anti-anxiety therapies (except benzodiazepines), antidepressants (selective serotonin reuptake inhibitors [SSRIs], tricyclic or tetracyclic), anti-psychotics (including chlorpromazine, thioridazine, haloperidol, risperidone, clozapine, or lithium), long-term use of certain antibiotics, any nonsteroidal anti-inflammatory drug (such as aspirin or ibuprofen), or antihistamines. These drugs may affect cervical secretions, raise body temperature, or delay ovulation.

Providing Symptoms-Based Methods

When to Start

Once trained, a woman or couple usually can begin using symptoms-based methods at any time. Women not using a hormonal method can practice monitoring their fertility signs

before they start using symptoms-based methods. Clients who cannot start immediately should be given another method to use until they can start.

Table 6-5. When to Start Symptoms-Based Methods

Woman's Situation	When to Start
Having regular menstrual cycles	Any time of the month No need to wait until the start of next monthly bleeding.
No monthly bleeding	Delay symptoms-based methods until monthly bleeding returns.
After childbirth (whether or not breastfeeding)	She can start symptoms-based methods once normal secretions have returned. Normal secretions will return later in breastfeeding women than in women who are not breastfeeding.
After miscarriage or abortion	She can start symptoms-based methods immediately with special counselling and support, provided she has no infection-related secretions or bleeding due to injury to the genital tract.
Switching from a hormonal method	She can start symptoms-based methods in the next menstrual cycle after stopping a hormonal method.
After taking emergency contraceptive pills	She can start symptoms-based methods once normal secretions have returned.

Explaining How to Use Symptoms-Based Methods

Ovulation Method/Cervical Mucus Method

IMPORTANT: If a woman has a vaginal infection or other condition that changes the cervical mucus, this method may be difficult to use.

Table 6-6. Using the Ovulation/Cervical Mucus Method

Basic Principles of the Method	How to Use the Method
Check cervical secretions daily	The woman checks every day for any cervical secretions with fingers, on underwear, or tissue paper or by sensation in or around the vagina.
Avoid unprotected sex on days of heavy monthly bleeding	Ovulation might occur early in the cycle, during the last days of monthly bleeding, and heavy bleeding could make mucus difficult to observe.

Basic Principles of the Method	How to Use the Method
<p>Resume unprotected sex until secretions begin</p>	<p>Between the end of monthly bleeding and the start of secretions, the couple can have unprotected sex, but not on 2 days in a row. (Avoiding sex on the second day allows time for semen to disappear and for cervical mucus to be observed.)</p> <p>It is recommended that they have sex in the evenings, after the woman has been in an upright position for at least a few hours and has been able to check for cervical mucus.</p>
<p>Avoid unprotected sex when secretions begin and until 4 days after “peak day”</p>	<p>As soon as she notices any secretions, she considers herself fertile and avoids unprotected sex.</p> <p>She continues to check her cervical secretions each day. The secretions have a “peak day”—the last day that they are clear, slippery, stretchy, and wet. She will know this has passed when, on the next day, her secretions are sticky or dry, or she has no secretions at all. She continues to consider herself fertile for 3 days after that peak day and avoids unprotected sex.</p>
<p>Resume unprotected sex</p>	<p>The couple can have unprotected sex on the fourth day after her peak day and until her next monthly bleeding begins.</p>

Figure 6-1. Example of a Fertility Wheel to Help Women Use Natural Methods

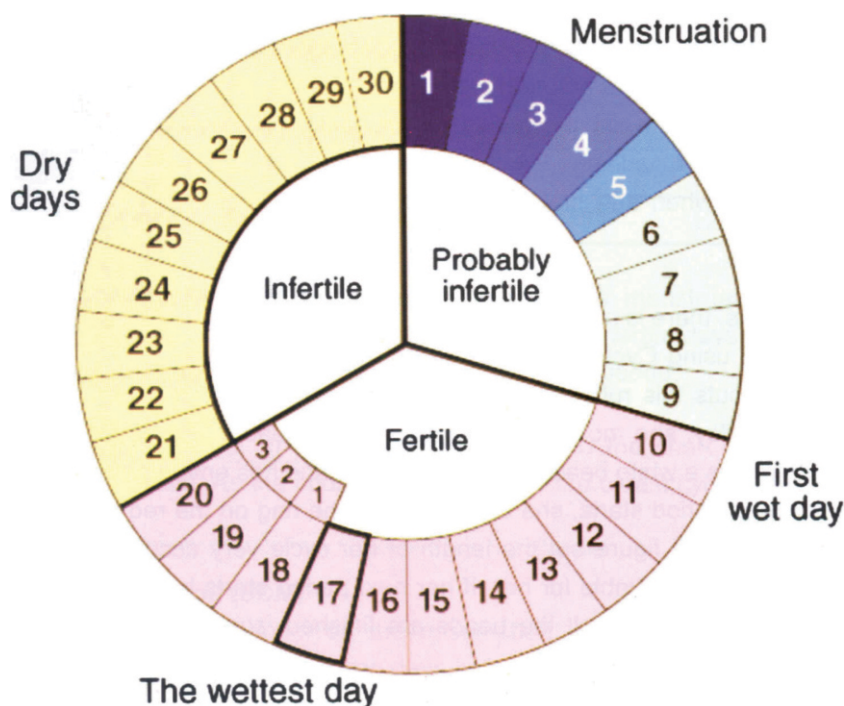

TwoDay Method

IMPORTANT: If a woman has a vaginal infection or other condition that changes cervical mucus, the TwoDay Method will be difficult to use.

Table 6-7. Using the TwoDay Method

Basic Principles of the Method	How to Use the Method
Check for secretions	<p>The woman checks for cervical secretions every afternoon and/or evening, on fingers, underwear, or tissue paper or by sensation in or around the vagina.</p> <p>As soon as she notices any secretions of any type, colour, or consistency, she considers herself fertile that day and the following day.</p>
Avoid sex or use another method on fertile days	<p>The couple avoids vaginal sex or uses condoms or a diaphragm on each day with secretions and on the day following a day with secretions.</p> <p>They can also use the withdrawal method or spermicides, but these are less effective.</p>
Resume unprotected sex after 2 dry days	<p>The couple can have unprotected sex again after the woman has had 2 dry days (days without secretions of any type) in a row.</p>

Basal Body Temperature (BBT) Method

IMPORTANT: If a woman has fever or other changes in body temperature, the BBT method will be difficult to use.

Basic Principles of the Method	How to Use the Method
Take body temperature daily	<p>The woman takes her body temperature at the same time each morning before she gets out of bed and before she eats anything. She records her temperature on a special graph.</p> <p>She watches for her temperature to rise slightly—0.2°–0.5° C (0.4°–1.0° F)—just after ovulation (usually about midway through the menstrual cycle).</p>
Avoid sex or use another method until 3 days after the temperature rise	<p>The couple avoids vaginal sex, or uses condoms or a diaphragm from the first day of monthly bleeding until 3 days after the woman's temperature has risen above her regular temperature. They can also use withdrawal or spermicides, but these are less effective.</p>

Basic Principles of the Method	How to Use the Method
Take body temperature daily	<p>The woman takes her body temperature at the same time each morning before she gets out of bed and before she eats anything. She records her temperature on a special graph.</p> <p>She watches for her temperature to rise slightly—0.2°-0.5°C (0.4°-1.0°F)—just after ovulation (usually about midway through the menstrual cycle).</p>
Avoid sex or use another method until 3 days after the temperature rise	<p>The couple avoids vaginal sex, or uses condoms or a diaphragm from the first day of monthly bleeding until 3 days after the woman's temperature has risen above her regular temperature. They can also use withdrawal or spermicides, but these are less effective.</p>

Sympto thermal Method (basal body temperature + cervical secretions + other fertility signs)

Table 6-9. Using the Sympto thermal Method

Basic Principles of the Method	How to Use the Method
Avoid unprotected sex on fertile days	<p>Users identify fertile and non-fertile days by combining BBT and ovulation method instructions.</p> <p>Women may also identify the fertile time by other signs such as breast tenderness and ovulatory pain (lower abdominal pain or cramping around the time of ovulation).</p> <p>The couple avoids unprotected sex between the first day of monthly bleeding and either the fourth day after peak cervical secretions or the third full day after the rise in temperature (BBT), whichever happens later.</p> <p>Some women who use this method have unprotected sex between the end of monthly bleeding and the beginning of secretions, but not on 2 days in a row.</p>

Withdrawal Method (Coitus Interruptus)

Coitus interruptus, or withdrawal, is one of the oldest forms of contraception known to man. Coitus interruptus is defined as sexual intercourse that is deliberately interrupted by withdrawal of the penis from the vagina prior to ejaculation. The withdrawal method is not particularly effective as a contraceptive method.

Mode of Action

Withdrawal prior to ejaculation reduces or eliminates the introduction of sperm into the vagina.

Effectiveness

- Perfect use failure rate in first year: 4 percent
- Typical use failure rate in first year: 27 percent

Advantages

- Withdrawal as a contraceptive method is better than no method at all.
- Incurs no expenditure.
- It has relatively few medical complications, except those brought about by an unwanted pregnancy or possible transmission of STIs.
- Requires no preparation or supplies.
- Has no adverse effect on fertility after discontinuation of method.

Limitations

- May not be applicable for couples with sexual dysfunction such as premature ejaculation or unpredictable ejaculation.
- May reduce sexual pleasure of woman and intensity of orgasm in man.
- Requires the couple to think about what is happening during sexual intercourse.
- Relies on the male removing the penis from the vagina at a point prior to orgasm and often when he is in a high state of arousal.
- Provides no protection against STIs such as HIV/AIDS, genital herpes, or gonorrhoea.
- Over the long term, many couples find the withdrawal method frustrating and unsatisfactory.

Medical Eligibility Criteria

All men can use withdrawal. No medical conditions prevent its use.

Method of Use

Starting time: Can begin at any time.

Explaining How to Use

When the man feels close to ejaculating, he should withdraw his penis from the vagina and ejaculate outside the vagina, keeping his semen away from her external genitalia.

If man has ejaculated recently, he should urinate before sex and wipe the tip of his penis to remove any sperm remaining.

Table 6-10. Advice on Use of the Withdrawal Method

Discussion Points on Use of Withdrawal	What to Advise the Man or Couple
Learning proper use can take time	Suggest that the couple also use another method until the man feels that he can use withdrawal correctly with every act of sex.
Greater protection from pregnancy is available	Suggest an additional or alternative family planning method. (Couples who have been using withdrawal effectively should not be discouraged from continuing.)
Some men may have difficulty using withdrawal	Explain that withdrawal is difficult for men who cannot sense consistently when ejaculation is about to occur or for men who ejaculate prematurely.
Can use emergency contraceptive pills (ECPs)	Explain ECP use in case a man ejaculates before withdrawing (see “Emergency Contraceptive Pills”, pp. 45-58 of <i>Family Planning: A Global Handbook for Providers</i>). Give ECPs if available.

FERTILITY AWARENESS-BASED (FAB) METHODS

Fertility awareness-based (FAB) methods do not protect against sexually transmitted infections (STIs), including HIV. If there is a risk of STI/HIV, the correct and consistent use of condoms is recommended. When used correctly and consistently, condoms offer one of the most effective methods of protection against STIs, including HIV. Female condoms are effective and safe, but are not used as widely by national programmes as male condoms.

CONDITION	CATEGORY ^a		CLARIFICATIONS/EVIDENCE
	A = accept, C = caution, D = delay		
	SYM	CAL	
* additional comments after this table	SYM = symptoms-based method CAL = calendar-based method		

Women with conditions that make pregnancy an unacceptable risk should be advised that FAB methods for pregnancy prevention may not be appropriate for them because of their relatively higher typical-use failure rates.

PERSONAL CHARACTERISTICS AND REPRODUCTIVE HISTORY

PERSONAL CHARACTERISTICS AND REPRODUCTIVE HISTORY	SYM	CAL	CLARIFICATIONS/EVIDENCE
PREGNANCY	NA	NA	NA = not applicable Clarification: FAB methods are not relevant during pregnancy.
LIFE STAGE			Clarification: Menstrual irregularities are common in post-menarche and perimenopause and may complicate the use of FAB methods.
a) Post-menarche	C	C	
b) Perimenopause	C	C	

FERTILITY AWARENESS-BASED (FAB) METHODS

Fertility awareness-based (FAB) methods do not protect against sexually transmitted infections (STIs), including HIV. If there is a risk of STI/HIV, the correct and consistent use of condoms is recommended. When used correctly and consistently, condoms offer one of the most effective methods of protection against STIs, including HIV. Female condoms are effective and safe, but are not used as widely by national programmes as male condoms.

CONDITION	CATEGORY ^a A = accept, C = caution, D = delay		CLARIFICATIONS/EVIDENCE
	SYM	CAL	
* additional comments after this table	SYM = symptoms-based method CAL = calendar-based method		
BREASTFEEDING*			
a) < 6 weeks postpartum	D	D	
b) ≥ 6 weeks	C	D	
c) After menses begins	C	C	
POSTPARTUM* (in non-breastfeeding women)			
a) < 4 weeks	D	D	
b) ≥ 4 weeks	A	D	
POST-ABORTION*	C	D	
REPRODUCTIVE TRACT INFECTIONS AND DISORDERS			
IRREGULAR VAGINAL BLEEDING*	D	D	
VAGINAL DISCHARGE*	D	A	
OTHER			
USE OF DRUGS THAT AFFECT CYCLE REGULARITY, HORMONES AND/OR FERTILITY SIGNS*	C/D	C/D	
DISEASES THAT ELEVATE BODY TEMPERATURE*			
a) Chronic diseases	C	A	
b) Acute diseases	D	A	

a Further explanation of A, C and D categories:

A = accept: There is no medical reason to deny the particular FAB method to a woman in this circumstance.

C = caution: The method is normally provided in a routine setting, but with extra preparation and precautions. For FAB methods, this usually means that special counselling may be needed to ensure correct use of the method by a woman in this circumstance.

D = delay: Use of this method should be delayed until the condition is evaluated or corrected. Alternative temporary methods of contraception should be offered.

7

BARRIER AND PROTECTIVE METHODS

Introduction

Barrier methods of contraception involve the use of mechanical devices that prevent sperm from entering into the cervix. The efficacies of all barrier methods are enhanced with the use of spermicides. Barrier and protective methods include vaginal methods and male and female condoms. Male condoms are available over the counter and at affordable price.

Policy

The available barrier and protective methods are to be offered to the client along with other contraceptives so that the client may choose the method she or he wants. Condoms are to be sold at government-prescribed rates.

Standards

- The client must be provided full information on the use and disposal of condoms.
- The client should be informed that only condoms prevent sexually transmitted infections (STIs).
- The client must be informed of the rare occurrence of allergic manifestations with the use of condoms.
- The client must be provided with emergency contraceptive in case of failure to method.

Male Condoms

A male condom is a sheath or covering made of thin latex rubber or vinyl that fits over a man's erect penis. Condoms are known by many different brand names and are of different sizes, shapes, colours, and textures.

Mode of Action

A condom works by creating a barrier that keeps sperm out of the vagina, thus preventing pregnancy. It also prevents infections present in the semen, on the penis, or in the vagina from infecting the other partner.

Effectiveness

When used correctly with every act of sex, about 2 pregnancies per 100 women occur over the first year of use. As commonly used, about 15 pregnancies per 100 women occur over the first year of use.

Advantages

- Prevent STIs, including HIV/AIDS, and pregnancy, when used correctly with every act of sexual intercourse. Consistent condom use reduces risks of HIV transmission by approximately 10 fold.
- Help protect against STIs, pelvic inflammatory disease (PID), chronic pain, and possibly cervical cancer in women and infertility in both men and women.
- Can be used to prevent STIs during pregnancy.
- Can be used soon after childbirth.
- Are safe and have no hormonal side effects.
- User-controlled-can be stopped at any time.
- Offer occasional contraception with no daily upkeep.
- Easy to keep on hand in case sex occurs unexpectedly.
- Can be used without seeing a health care provider. "" Usually easy to obtain and are sold in many places.
- Often help prevent premature ejaculation (help the man last longer during sex).
- Male involvement is encouraged and is essential.
- Availability of wide range of condom types.

Limitations

- Latex condoms may cause itching in a few people who are allergic to latex.
- Some people may be allergic to the lubricant on some brands of condoms.
- May decrease sensation, making sex less enjoyable for either partner.
- The couple must take time to put the condom on the erect penis before sex.
- The supply of condoms must be on hand even if the woman or man is not expecting to have sex.
- There is a small possibility that the condom will slip off or break during sex.
- Condoms can weaken if stored too long or in too much heat or sunlight, or if used with oil-based lubricants, and then may break during use.
- A man's cooperation is needed for a woman to protect herself from pregnancy and STIs.

- May embarrass some people to buy, ask partner to use, put on, take off, or dispose condoms.
- May cause man to lose erection.
- Plain condoms may decrease lubrication and provide less stimulation for woman.
- Require prompt withdrawal after ejaculation, which may decrease pleasure.
- Make sex messy for the man (getting rid of condom).
- Require knowledge for successful use.

Client Assessment as per World Health Organization Medical Eligibility Criteria for Male Condoms

In general, anyone can use condoms safely and effectively. Only one medical condition prevents the use of condoms, i.e., severe allergy (severe redness, itching, and swelling after use). The client can be asked about this allergy and no tests are indicated. If the client is at risk of STIs including HIV/AIDS, s/he may use the condoms despite the allergy.

Method of Use

Male condom use can be started at any time. Care should be taken to use condoms for all sexual acts. Just one unprotected act of sexual intercourse can lead to pregnancy or an STI.

Technique of Use

- Make sure condoms are stored properly and obtained from a good source.
- Check manufacturing or expiry date on package.
- Take out condom from package.
- Do not use teeth or sharp objects to open condom package.
- Unroll condom slightly to make sure it unrolls properly.
- Place condom on the tip of the erect penis.
- Squeeze air out of tip of condom about 1–2 cm.
- Unroll condom down the penis.
- If condom is initially placed on the penis backwards, do not turn it around, throw it away and start with a new one.
- Start the sex act with condom on.
- After ejaculation, hold on to the condom at the base of penis while withdrawing it.
- Withdraw while still erect.
- Take off the condom carefully, without spilling semen.
- Tie the open end of the condom to prevent spills or leaks.
- Dispose of the condom safely.

Side Effects and Management

If the client reports any problems with condoms: Do not dismiss the client's concerns or take them lightly. If the client is not satisfied, help him in choosing another contraceptive.

Table 7-1. Male Condoms: Side Effects and Their Management

Side Effect	Management
Itching or rash on genitals	<ul style="list-style-type: none"> • If itching continues, check for infection. Treat or refer for treatment as appropriate. • Recommend a dry condom if client had been using a lubricated condom. • If problem continues, help client to choose another method if client is not at risk of STIs. • For clients at risk of STIs, urge continued use of condom despite discomfort.
Man cannot maintain an erection while using condom	<ul style="list-style-type: none"> • This is often due to embarrassment. • Discuss how to make condom use enjoyable by having partner put it on. With counselling and experience, the problem may be solved.

Counselling

Couples desiring to use condoms often benefit from specific instructions. Use a model and actual condom. Counsel new users about:

- Options among condom types
- Storage for safety and ready access
- How to negotiate condom use with partner and when to place condom on "" How to use the condom correctly

If a condom breaks:

- Clients must use emergency contraceptives to prevent pregnancy.

Provide the following information on care for condoms:

- Store condoms in a cool, dark place, if possible. Heat and light damage condoms.
- If possible, use lubricated condoms that come in square wrappers and are packaged so that light does not reach them. Lubrication may help prevent tears.
- Handle condoms carefully. Fingernails and rings can tear them.
- Do not unroll condoms before use. This may weaken them. Also, an unrolled condom is difficult to put on.
- Don't use condom if more than 5 years of manufactured or damaged package
- Is uneven or changed in colour.
- Feels brittle, dried out, or very sticky.

Explain specific reasons to see a health care provider if either partner:

- Has symptoms of STIs such as sores on the genitals, pain when urinating, or a discharge.
- Has an allergic reaction to condoms (itching, rash, irritation).
- Other specific reasons to return: need more condoms, dissatisfied with condoms for any reason, have any questions or problems.

Follow-Up

At any return visit:

- Ask if the client has any questions or anything to discuss.
- Ask the client about his or her experience with condoms, whether the client is satisfied, and whether the client has any problems. Give any information and advice that the client needs.
- If client is satisfied: Give client plenty of condoms. Give each client a 3-month supply of condoms, if possible, or more. How often people have sex varies, but for most clients, 40 condoms probably will last for at least 3 months.
- If the client had intercourse, did he/she have intercourse even once without using a condom?
- Does the client know how to use ECPs? Does he/she need ECPs?
- If the client has problems that cannot be resolved, help the client choose another method.
- Emphasize to clients at risk for STIs including HIV/AIDS to keep using condoms despite any dissatisfaction. Explain that only condoms protect against STIs.

Female Condoms

The female condom is a sheath, or lining, that fits loosely inside the vagina; it is made of thin, transparent, soft plastic, with a flexible ring at both ends:

- One ring at the closed end helps to insert the condom.
- The ring at the open end holds part of the condom outside the vagina.

Mode of Action

The mode of action of the female condom is the same as that of the male condom.

Effectiveness

When used correctly with every act of sex, about 5 pregnancies per 100 women occur over the first year of use. As commonly used, about 21 pregnancies per 100 women occur over the first year of use.

Advantages

- Cause 97 percent reduction in incidence of HIV infection.
- Do not require male partner's erection for use.
- Are controlled by the woman.
- Are designed to prevent both STIs and pregnancy.
- No medical conditions appear to limit use.
- No apparent side effects, no allergic reactions.

- Intercourse may be more pleasurable because fear of pregnancy and STIs is decreased.
- If woman inserts the condom, she is better assured that she is somewhat protected.
- Make sex less messy for the woman after removal of the condom. "" No medical visit required to start use.
- Immediately effective after placement.
- Provide an option to women whose partners cannot or will not use the male condom. May circumvent some concerns men have with male condoms.
- Can be safely used by people with latex allergies or sensitivities.
- Opportunity for women to share the responsibility for the condoms with their partners.
- Polyurethane, the material from which female condoms are made, is less likely to cause an allergic reaction than male latex condoms. With both types, the likelihood of breakage is very small if the condoms are used correctly.
- The female condom will protect against most STIs and pregnancy if used correctly.
- The polyurethane is thin and conducts heat well, so sensation is preserved.
- The female condom can be used with oil-based lubricants.
- There are no special storage requirements because polyurethane is not affected by changes in temperature and dampness. The expiry date for female condoms is 5 years from the date of manufacture.

Limitations

- Are expensive.
- Ring is visible outside the vagina.
- Can make noises during intercourse.
- Only somewhat effective as commonly used.
- Usually need partner's consent and cooperation.
- Regular supply is required.
- Woman has to touch her genitals.
- Some women find the female condom difficult to insert and remove.
- Have a higher failure rate in preventing pregnancy than non-barrier methods such as the oral contraceptive pill.
- It is recommended that a female condom be used only once.
- Client Assessment as per World Health Organization Medical Eligibility Criteria for Female Condoms
- All women can use the plastic female condom. No medical condition prevents the use of this method.

Method of Use

A woman can begin using female condoms at any time during her monthly cycle and soon after childbirth, abortion, or miscarriage.

Technique of Use

- Open packaging carefully. Avoid scissors or sharp objects that could cut or tear the condom.

- The client should rest comfortably in a squatting or lithotomy position.
- Compress the inner ring of the device and introduce the condom into the vagina much like a diaphragm. Use the inner ring to guide the sheath high into the vagina until the outer ring rests against the vulva. Rotate the inner ring to stabilize the device in the vault. Avoid tearing the condom with fingernails or jewellery. See package instructions for details and drawings illustrating insertion technique.
- intercourse and should take care to avoid penile contact outside the female condom.
- The man should monitor for any friction between penis and condom, which can cause breakage or inversion of the device.
- Remove the condom immediately after intercourse and then discard it safely.
- If there is any dislocation of the female condom during intercourse or any breakage or spillage of the ejaculate into the genitalia, have the client use emergency contraceptive pills (ECPs) as soon as possible. If she is at risk for STIs when the condom fails, seek medical care.

Caution: When a latex male condom is used with a polyurethane female condom, there can be an increased risk of breakage of either or both condoms. The oil-based lubricant of the female condom can cause breakage of the male condom. Friction could cause breakage of either.

Table 7-2. Female Condoms: Side Effects and Their Management

Side Effect	Management
Difficulty in inserting condom	<ul style="list-style-type: none"> • Reinstruct the client.
Problem with removal	<ul style="list-style-type: none"> • Recommend relaxation techniques or suggest that the partner may remove it.
Condom dislodgement or penis inserted outside condom	<ul style="list-style-type: none"> • Insert a new condom prior to continuing intercourse. • Use ECPs if any spill suspected. • If at risk for STIs, seek medical care.
Allergy to condom	<ul style="list-style-type: none"> • Occurs very rarely.

Follow-Up/Return Visit

At any return visit, ask:

- Did the client have any problems using the female condom?
- If the client had intercourse, did she have intercourse even once without using a condom?
- Does the client know how to use ECPs? Does she need more ECPs?
- Does the client plan to have children? Or plan to have more children? When? "" Ask if the client has any questions or anything to discuss.
- Ask the client about her experience with the method, whether she is satisfied, and whether she has any problems. Give her any information or help that she needs and invite her to return again any time she has questions or concerns. If she has problems that cannot be resolved, help her choose another method.
- Ask if she has had any health problems since her last visit



ORAL CONTRACEPTIVE PILLS

Introduction

Oral contraceptive pills (OCPs) have been available since the 1960s. The early preparations contained 50 mcg of oestrogen, but modern preparations contain 20-35 mcg and are called "low-dose" OCPs. Most preparations contain a combination of an oestrogen (usually ethinyl estradiol, in a low dose of 20-35 mcg) and a progestin (norethindrone, norgestrel, desogestrel, or norgestimate). These are called "combined oral contraceptive pills" (COCs). There are two types of COC pill packets. Some packets have 28 pills. These contain 21 "active" pills, which contain hormones, followed by seven "reminder" pills of a different colour, which do not contain hormones, but only iron or lactose. Other packets usually have 21 "active" pills. Women who use oral contraceptives swallow a pill each day to prevent pregnancy.

Progestin-only pills (POPs) are also available, and are useful for women who cannot take oestrogen or are lactating (COCs are not recommended during the initial six months postpartum). These are called "mini-pills."

Policy

- OCPs are not to be given to a woman who is pregnant or is suspected to be pregnant.
- COCs are not to be given to a lactating mother until the child is 6 months of age.
- POPs are to be given to a lactating mother as soon as after child birth.
- OCPs are not to be recommended approximately 4 weeks before and 6 weeks after major surgery that requires long-term immobilization.

Standards

The following standards will be observed:

- The client should be given full information about the use, risks, advantages, and possible side effects before OCPs are prescribed for her.
- Pills should be given only to those who meet the Medical Eligibility Criteria (MEC).

Combined Oral Contraceptive Pills

Mode of Action

The combined pills contain both oestrogen and progestin. They act in the following ways:

- Inhibit ovulation.
- Thicken cervical mucus.
- Make the endometrium less suitable for implantation.

There is no evidence of a harmful effect if an unsuspecting pregnant woman inadvertently uses OCPs; nevertheless, a woman should be given OCPs only when it is reasonably certain she is not pregnant.

Effectiveness

Effectiveness Depends on the User

- Risk of pregnancy is greatest when a woman starts a new pill pack after the prescribed time, or misses three or more pills.
- As commonly used, about 8 pregnancies occur per 100 women using COCs over the first year. This means that 92 of every 100 women using COCs will not become pregnant.
- When pills are taken regularly, less than 1 pregnancy occurs per 100 women using COCs over the first year.

Advantages

- Very effective when used correctly.
- No need to do anything at the time of sexual intercourse.
- Increased sexual enjoyment because no need to worry about pregnancy.
- Monthly periods are regular with lighter monthly bleeding and fewer days of bleeding.
- Can be used as long as a woman wants to prevent pregnancy.
- No rest period needed.
- Can be used at any age from adolescence to menopause.
- Can be used by women who have children and by nulliparous women.
- User can stop taking pills at any time.
- Fertility returns soon after stopping.
- Can be used as an emergency contraceptive after unprotected sex.
- Can prevent or decrease iron deficiency anaemia.
- Help prevent:
 - ◆ Ectopic pregnancies
 - ◆ Endometrial cancer
 - ◆ Ovarian cancer
 - ◆ Ovarian cysts
 - ◆ Pelvic inflammatory disease (PID)

- ◆ Benign breast disease
- Reduce:
 - ◆ Menstrual cramps
 - ◆ Menstrual bleeding problems
 - ◆ Ovulation pain
 - ◆ Symptoms of polycystic ovarian syndrome (irregular bleeding, acne, excess hair on face or body)
 - ◆ Symptoms of endometriosis (pelvic pain, irregular bleeding)

Limitations

Common side effects (not signs of sickness):

- Nausea (most common in first 3 months).
- Spotting or bleeding between menstrual periods, especially if a woman forgets to take her pills or takes them late (most common in first 3 months).
- Mild headaches.
- Breast tenderness.
- Slight weight gain.
- Amenorrhoea (some women see amenorrhoea as an advantage).
- Not highly effective unless taken every day. Difficult for some women to remember every day.
- New packet of pills must be at hand every 28 days.
- In a few women, may cause mood changes including depression and less interest in sex.
 - ◆ Very rarely can cause stroke, blood clots in deep veins of the legs, or heart attack. Those at highest risk are women with high blood pressure and women who are aged 35 or older and at the same time smoke 15 or more cigarettes per day.
 - ◆ Do not protect against sexually transmitted infections (STIs), including HIV.

Topic	MEC Recommendations
1. Recommendations for combined hormonal contraceptive (CHC) use by age group (CHCs include combined oral contraceptives, combined injectable contraceptives, combined patch and combined vaginal ring)	
< 40 years	Women from menarche through 40 years of age can use CHCs without restriction (MEC Category 1).
= 40 years	Women 40 years and older can generally use CHCs (MEC Category 2).
2. Recommendations for CHC use among breastfeeding women	
< 6 weeks postpartum	Breastfeeding women < 6 weeks postpartum should not use CHCs (MEC Category 4).
= 6 weeks to <6 months postpartum	Breastfeeding women = 6 weeks to < 6 months postpartum (primarily breastfeeding) generally should not use CHCs (MEC Category 3).
= 6 months postpartum	Breastfeeding women = 6 months postpartum can generally use CHCs (MEC Category 2).
3. Recommendations for CHC use among postpartum women	
< 21 days postpartum without other risk factors for venous thromboembolism (VTE)	Women who are < 21 days postpartum and do not have other risk factors for VTE generally should not use CHCs (MEC Category 3).

< 21 days postpartum with other risk factors for VTE	Women who are < 21 days postpartum with other risk factors for VTE should not use CHCs (MEC Category 4).
= 21 days to 42 days postpartum without other risk factors for VTE	Women who are = 21 days to 42 days postpartum without other risk factors for VTE can generally use CHCs (MEC Category 2).
= 21 days to 42 days postpartum with other risk factors for VTE	Women who are = 21 days to 42 days postpartum with other risk factors for VTE generally should not use CHCs (MEC Category 3).
> 42 days postpartum	Women who are > 42 days postpartum can use CHCs without restriction (MEC Category 1).
4. Recommendations for CHC use among women with superficial venous disorders	
Varicose veins	Women with varicose veins can use CHCs without restriction (MEC Category 1).
Superficial venous thrombosis (SVT)	Women with SVT can generally use CHCs (MEC Category 2).
5. Recommendations for CHC use among women with known dyslipidaemias	
Known dyslipidaemias without other known cardiovascular risk factors	Women with known dyslipidaemias without other known cardiovascular risk factors can generally use CHCs (MEC Category 2).
12. Recommendations for use of hormonal contraception for women at high risk of HIV infection, women living with HIV, and women living with HIV using antiretroviral therapy (ART)	
12a. Women at high risk of HIV infection	Women at high risk of acquiring HIV can use the following hormonal contraceptive methods without restriction: COCs, combined injectable contraceptives (CICs), combined contraceptive patches and rings, POPs, POIs (DMPA and NET-EN), and LNG and ETG implants (MEC Category 1). Women at high risk of acquiring HIV can generally use LNG-IUDs (MEC Category 2).
12b. Women living with asymptomatic or mild HIV clinical disease (WHO stage 1 or 2)	Women living with asymptomatic or mild HIV clinical disease (WHO stage 1 or 2) can use the following hormonal contraceptive methods without restriction: COCs, CICs, combined contraceptive patches and rings, POPs, POIs (DMPA and NET-EN), and LNG and ETG implants (MEC Category 1). Women living with asymptomatic or mild HIV clinical disease (WHO stage 1 or 2) can generally use the LNG-IUD (MEC Category 2).
12c. Women living with severe or advanced HIV clinical disease (WHO stage 3 or 4)	Women living with severe or advanced HIV clinical disease (WHO stage 3 or 4) can use the following hormonal contraceptive methods without restriction: COCs, CICs, combined contraceptive patches and rings, POPs, POIs (DMPA and NET-EN), and LNG and ETG implants (MEC Category 1). Women living with severe or advanced HIV clinical disease (WHO stage 3 or 4) generally should not initiate use of the LNG-IUD (MEC Category 3) until their illness has improved to asymptomatic or mild HIV clinical disease (WHO stage 1 or 2). Women who already have an LNG-IUD inserted and who develop severe or advanced HIV clinical disease need not have their IUD removed (MEC Category 2 for continuation).
12d. Women living with HIV using antiretroviral therapy (ART)	Women taking any NRTI can use all hormonal contraceptive methods without restriction: COCs, CICs, combined contraceptive patches and rings, POPs, POIs (DMPA and NET-EN), and LNG and ETG implants (MEC Category 1). Women taking any NRTI can generally use the LNG-IUD (MEC Category 2), provided that their HIV clinical disease is asymptomatic or mild (WHO Stage 1 or 2). Women living with severe or advanced HIV clinical disease (WHO stage 3 or 4) and taking any NRTI generally should not initiate use of the LNG-IUD (MEC Category 3 for initiation) until their illness has improved to asymptomatic or mild HIV clinical disease. Women taking any NRTI who already have had an LNG-IUD inserted and who develop severe or advanced HIV clinical disease need not have their IUD removed (MEC Category 2 for continuation).

Client Assessment as per World Health Organization Medical Eligibility Criteria for Combined Oral Contraceptive Pills

Ask the client the following questions about known medical conditions. Examinations and tests are not necessary. If she answers "no" to all of the questions, then she can start COCs if she wants. If she answers "yes" to a question, follow the instructions. In some cases she can still start COCs. These questions also apply for the combined patch and the combined vaginal ring.

1. Is the client breastfeeding a baby younger than 6 months old?
 If fully or nearly fully breastfeeding: Give her COCs and tell her to start taking them 6 months after giving birth or when breast milk is no longer the baby's main food- whichever comes first.
 If partially breastfeeding: She can start COCs as soon as 6 weeks after childbirth.
2. Has the client had a baby in the last 3 weeks but she is not breastfeeding? Give her COCs now and tell her to start taking them 3 weeks after childbirth.
3. Does the client smoke cigarettes?
 If she is 35 years of age or older and smokes, do not provide COCs. Convince her to stop smoking and help her choose another method.
4. Does the client have cirrhosis of the liver, a liver infection, or liver tumour? (Are her eyes or skin unusually yellow? [Signs of jaundice]) Has she ever had jaundice when using COCs?
 If she reports serious active liver disease (jaundice, active hepatitis, mild or severe cirrhosis, liver tumours) or ever had jaundice while using COCs, do not provide COCs. Help her choose a method without hormones.
5. Does the client have high blood pressure?
 If blood pressure cannot be checked and she reports a history of high blood pressure or if she is being treated for high blood pressure, do not provide COCs. Refer her for a blood pressure check if possible or help her choose a method without oestrogen. Check blood pressure if possible: If her blood pressure is below 140/90 mm Hg, provide COCs. If her systolic blood pressure is 140 mm Hg or higher or diastolic blood pressure is 90 or higher, do not provide COCs. Help her choose a method without oestrogen, but not progestin-only injectables if systolic blood pressure is 160 or higher or diastolic pressure is 100 or higher. (One blood pressure reading in the range of 140-159/90-99 mm Hg is not enough to diagnose high blood pressure. Give her a backup method to use until she can return for another blood pressure check, or help her choose another method now if she prefers. If her blood pressure at next check is below 140/90, she can use COCs.)
6. Has the client had diabetes for more than 20 years or damage to her blood vessels, vision, kidneys, or nervous system caused by diabetes?
 Do not provide COCs. Help her choose a method without oestrogen but not progestin-only injectables.
 World Health Organization Medical Eligibility Criteria for Combined Oral Contraceptive Pills

7. Does the client have gall bladder disease now or is she taking medication for gall bladder disease?
Do not provide COCs. Help her choose another method, but not the combined patch or combined vaginal ring.
8. Has the client ever had a stroke, blood clot in her legs or lungs, heart attack, or other serious heart problems?
If she reports heart attack, heart disease, or stroke, do not provide COCs. Help her choose a method without oestrogen, but not progestin-only injectables.
If she reports a current blood clot in the deep veins of the legs or lungs (not superficial clots), help her choose a method without hormones.
9. Does the client have or has she ever had breast cancer?
Do not provide COCs. Help her choose a method without hormones.
10. Does the client sometimes see a bright area of lost vision in the eye before a very bad headache (migraine aura)? Does she get throbbing, severe headaches, and often on one side of the head, which can last from a few hours to several days and can cause nausea or vomiting (migraine headaches)? Such headaches are often made worse by light, noise, or moving about.
If she has migraine aura or migraine headaches without aura and is age 35 or older, do not provide COCs. Help these clients choose a method without oestrogen. If she is under 35 and has migraine headaches without aura, she can use COCs.
11. Is the client taking medications for seizures or taking rifampicin for tuberculosis or other medicine?
If she is taking barbiturates, carbamazepine, oxcarbazepine, phenytoin, primidone, topiramate, or rifampicin, do not provide COCs. They can make COCs less effective. Help her choose another method, but not progestin-only pills or implants.
12. Is the client planning major surgery that will keep her from walking for 1 week or more?
If so, she can start COCs 2 weeks after the surgery. Until she can start COCs, she should use a backup method.
13. Does the client have conditions that could increase her chances of heart disease (coronary artery disease) or stroke, such as older age, smoking, high blood pressure, or diabetes?
Do not provide COCs. Help her choose a method without oestrogen but not progestin-only injectables.

Indications

- Have or have not had children
- Are fat or thin
- Are any age, including adolescents and over 40 (except clients who smoke and are above 35 years of age)
 - Smoke cigarettes but are below 35 years of age
 - ◆ Have just had an abortion or miscarriage
 - ◆ Heavy, painful menstrual periods or iron deficiency anaemia (condition may improve)
 - ◆ Irregular menstrual periods

- ◆ Benign breast disease
- ◆ Diabetes without vascular, kidney, eye, or nerve disease
- ◆ Mild headaches
- ◆ Varicose veins
- ◆ Malaria
- ◆ Thyroid disease
- ◆ Pelvic inflammatory disease (PID)
- ◆ Endometriosis
- ◆ Benign ovarian tumours
- ◆ Uterine fibroids
- ◆ Past ectopic pregnancy
- ◆ Tuberculosis (unless taking rifampicin)

Method of Use

Starting Time

- ◆ Any of the first 5 days after menstrual bleeding starts, if she has a normal cycle. The first day of menstrual bleeding may be easiest to remember.
- ◆ Any other time it is reasonably certain that she is not pregnant. If more than 5 days since menstrual bleeding started, she can begin COCs with back up method but should avoid sex or also use condoms for the next 7 days. Her usual bleeding pattern may change temporarily.
- ◆ When switching from injectables or implants, she can start COCs immediately if it is reasonably certain she is not pregnant. No need to wait for a first period after using injectables or implants.
- ◆ After she stops breastfeeding or 6 months after childbirth, whichever comes first.
- ◆ Three to 6 weeks after childbirth if she is not breastfeeding. No need to wait for menstrual periods to return to be certain that she is not pregnant.
- ◆ Six weeks or more after childbirth if she is partially breastfeeding, or any time it is reasonably certain that she is not pregnant. If not reasonably certain, she should avoid sex or use condoms or spermicide until her first period starts, and then begin COCs.
- ◆ In the first 7 days after first- or second- trimester miscarriage or abortion.
- ◆ Later, at any time it is reasonably certain that she is not pregnant.

Technique

- 28-pill packet (containing 21 white [active] and seven brown [placebo]):
- Start the white pills within the first 5 days of the menstrual cycle.
- If not menstruating, start the pills on the same day and keep taking one pill every day until finishing all of the white pills, but use a backup method for the first 7 days of taking the pills.
- Start the brown pills immediately after finishing the white pills and continue taking one pill every day for 7 days.
- Menses usually starts 2-3 days after starting the brown pills.
- After finishing the seven brown pills, start the new packet of 28 pills (it does not matter

if bleeding continues).

21 pill packet (containing 21 white pills):

- Start the pills within the first 5 days of the menstrual cycle.
- If not menstruating, start taking the pill and keep taking one pill every day until finishing all of the pills, but use a backup method for the first 7 days of taking the pills.
- After finishing the pills, do not take any pills for the next 7 days.
- Menses usually starts 2-3 days after the pills are finished.
- After a 7-day period of no pills, start the new packet of 21 pills.

Missed Pills

Instructions If a Woman Forgets to Take a Pill or Pills

- Take a missed hormonal pill (white) as soon as possible.
- Keep taking pills as usual, one each day. (She may take two pills at the same time or on the same day.)

Missed one or two pills? Started a new pack 1 or 2 days late?

- Take a hormonal pill as soon as possible.
- There is little or no risk of pregnancy.

Missed three or more pills in the first or second week? Started a new pack 3 or more days late?

- Take a hormonal pill as soon as possible.
- Use a backup method for the next 7 days.
- Also, if she had sex in the past 5 days, she should consider using emergency contraceptive pills (ECPs).

Missed three or more pills in the third week?

- Take a hormonal pill as soon as possible.
- Finish all hormonal pills in the pack. Throw away the seven non-hormonal pills in a 28-pill pack.
- Start a new pack the next day.
- Use a backup method for the next 7 days.
- Also, if she had sex in the past 5 days, she should consider using ECPs.

Missed any non-hormonal pills (brown pills)? (Last seven pills in 28-pill pack)

- Discard the missed non-hormonal pill.
- Keep taking COCs, one each day, and start the new pack as usual.

Severe vomiting or diarrhoea?

- If she vomits within 2 hours after taking a pill, she should take another pill from her pack as soon as possible, and then keep taking pills as usual.
- If she has vomiting or diarrhoea for more than 2 days, follow instructions for missed pills, above.

Side Effects and Management

Most women tolerate COCs very well. However, a number of women may have side effects, especially in the first few months of taking the pill.

Table 8-1. Combined Oral Contraceptive Pills: Side Effects and Their Management

Side Effect	Management
Dizziness or nausea	<ul style="list-style-type: none"> • Make sure she is taking the pill at bed time. • She should take the pill with meals and not on an empty stomach. • Check for pregnancy; if no cause is found, reassure the client.
Vomiting	
<ul style="list-style-type: none"> • Once or twice during the day 	<ul style="list-style-type: none"> • If she vomits within 2 hours of taking the pill, ask her to take an extra pill from another packet. • Make sure she is taking the pill just before going to bed and with food.
<ul style="list-style-type: none"> • More than twice a day 	Pills should be stopped; inform her that withdrawal bleeding will occur. Change over to another suitable contraceptive method of her choice.
Severe diarrhoea	If she has diarrhoea for more than 2 days, follow instructions for missed pills as mentioned above.
More than 24 hours of tenderness or fullness of the breast	<ul style="list-style-type: none"> • Follow the instructions for missed pills. <ul style="list-style-type: none"> – Examine breasts for lump. – If none, reassure the client. – Prescribe a mild analgesic (paracetamol), if necessary.
Side Effect	Management
Weight gain	
<ul style="list-style-type: none"> • Less than 2 kg in months 	Ask if her appetite has increased, and if so, ask her to decrease food intake, especially of fats and sweets.
<ul style="list-style-type: none"> • More than 2 kg in 3 months 	Stop pills; provide another suitable contraceptive method.
Spotting or irregular bleeding	
<ul style="list-style-type: none"> • If due to STI or PID 	Continue treatment and COCs.
<ul style="list-style-type: none"> • Within 3 months of starting the pills 	<ul style="list-style-type: none"> • Reassure the client that it is transitory. • Ask if she has been forgetting to take pills. If so, ask her to be regular and take the pill at the same time each day. • For temporary relief, give: <ul style="list-style-type: none"> – Tab. ibuprofen 800 mg TDS (max) after meals for 5 days, or – Tab. Ponstan, 2xTDS, beginning when irregular bleeding starts.
<ul style="list-style-type: none"> • After 3 months of starting the pills 	If this persists despite the client being regular in taking pills, then stop pills and give a backup method and watch/investigate. If no problem, reassure and provide another suitable contraceptive method.

Amenorrhoea	<ul style="list-style-type: none"> • Check for pregnancy. • If negative, reassure and give oral pills with higher dose of hormones. • If amenorrhoea persists (after changing pills) for more than 3 months, stop pills and give another suitable contraceptive method.
Rise in BP (above 140/90)	Advise her to come to the clinic for a regular check of BP on three visits, 1 week apart. If high BP persists, stop pills and give another suitable method and refer.
Severe migraine	If it develops while using COCs, stop the pills. Give her another suitable contraceptive method.
Rare side effects	
Acne	
<ul style="list-style-type: none"> • Mild acne 	<ul style="list-style-type: none"> • Avoid use of creams containing lanolin. • Ask her to keep the skin clean. • Avoid fatty food.
<ul style="list-style-type: none"> • Severe acne 	Stop pills. Give another suitable contraceptive method.
Pigmentation of skin (especially of face)	<ul style="list-style-type: none"> • Stop pills. • Give another suitable contraceptive method.
Generalized loss of hair	<ul style="list-style-type: none"> • Avoid use of creams containing mercury. • Ask if this followed after the start of pills; if so, stop pills and give another suitable contraceptive method.
Depression or irritability	If confirmed to have happened after starting the pills, stop pills, and give another suitable contraceptive method.

Counselling

A woman who chooses low-dose COCs can benefit from good counselling. A friendly provider who listens to a woman's concerns, answers her questions, and gives clear, practical information about side effects and advice about their proper use will help the woman use COCs with success and satisfaction.

The health care provider should follow these steps to provide COCs:

- Show her which kind of pill packet you are giving her, 21 pills or 28 pills.
- Tell her about the advantages and limitations.
- Inform her about the common side effects and what to do.
- Give her a sufficient number of pill packets, depending on her need. Running out of pills is a major reason for unintended pregnancies.
- Explain how to use COCs and what to do if she misses pills.
- If possible, give her condoms or spermicide to use:
 - ◆ Until she can start taking her pills (if needed).
 - ◆ If she starts a packet of pills late, if she forgets several pills in a row, or if she stops taking oral contraceptives for any reason.
 - ◆ If she or her spouse is at risk of HIV/AIDS or any other STI, show her how to use condoms.
- Plan a return visit in time to give her more pills before her supply runs out.
- Invite the client to come back to the clinic at any time if she has questions, problems, or wants another method.

- Ask her to repeat the most important instructions and, using the pill packet, show how she will take her pills.
- Ask her if she has any questions, fears, or concerns, and answer her concerns respectfully and caringly.
- For any unscheduled visit, ask her to bring the packet in use with her.

Follow-Up

The follow-up care and support of the client is very important for continued use of OCPs. The health care provider has a responsibility to keep the client satisfied, in case she has side effects, by providing correct information and reassurance.

Explain Specific Reasons to See a Trained Health Care Provider

- Describe the symptoms of problems that require medical attention.
- Serious complications of pill use are rare. Still, a client should see a doctor or return to the clinic if she has questions, or problems that may be symptoms of a serious problem or warning signs.

Warning Signs

COCs may or may not cause these problems. But if any of the following occur, the client should immediately contact a trained provider:

- A= Abdominal pain (severe)
- C= Chest pain (severe) with cough and shortness of breath
- H= Headache (severe) with dizziness and shortness of breath
- E= Eye problems (vision loss, blurring, or flashes of light)
- S= Severe leg pain (calf or thigh)

Helping Clients at Any Return Visit

- At any return visit, ask the client:
 - If she has any questions or anything to discuss.
 - About her experience with the method, whether she is satisfied, and whether she has any problems. Give her any information or help that she needs and invite her to return again any time she has questions or concerns. If she has problems that cannot be resolved, help her choose another method.
- If she has had any health problems since her last visit, and assess the following:
 - ◆ Check blood pressure once a year if possible.
 - ◆ Ask if she has developed high blood pressure, heart disease due to blocked arteries, stroke, breast cancer, active liver disease, or gall bladder disease, or she is taking medicines for seizures, rifampicin, or griseofulvin. If appropriate, help her choose another method.
 - ◆ Ask if she has developed very bad headaches. If appropriate, help her choose another suitable method.

Plan for Her Next Visit

If she has not developed any condition, that means she can use COCs; provide more supplies if needed. Plan for her next visit before she needs more pills.

Minimum Record

Maintain the following record for follow-up of the client:

- Daily register.
- Client record card.
- Client card, to be given to the client with information such as:
 - ◆ Name, age, and registration number
 - ◆ Type of COCs given
 - ◆ Date for follow-up visit
- Update records at each visit including details of complaints, side effects, and treatment given.

Progestin-Only Pills

Effectiveness

- Effectiveness depends on the user. For women who have monthly bleeding, risk of pregnancy is greatest if pills are taken late or missed completely.

For breastfeeding women:

- As commonly used, about 1 pregnancy occurs per 100 women using POPs over the first year. This means that 99 of every 100 women will not become pregnant.
- When pills are taken every day, less than 1 pregnancy occurs per 100 women using POPs over the first year (3 per 1,000 women).

For women not breastfeeding, they are less effective:

- As commonly used, about 3–10 pregnancies occur per 100 women using POPs over the first year. This means that 90–97 of every 100 women will not become pregnant.
- When pills are taken every day at the same time, less than 1 pregnancy occurs per 100 women using POPs over the first year (9 per 1,000 women).

Advantages

- Protect against pregnancy.
- Very effective when used correctly.
- No need to do anything at the time of sexual intercourse.
- Increased sexual enjoyment because no need to worry about pregnancy.
- Monthly periods are regular; lighter monthly bleeding and fewer days of bleeding; milder and fewer menstrual cramps.
- Can be used for as long as a woman wants to prevent pregnancy.
- No rest period needed.
- Can be used at any age from adolescence to menopause.
- User can stop taking pills at any time.

- Fertility returns soon after stopping.
- Can be used as an emergency contraceptive after unprotected sex.
- Can be used by nursing mothers starting 6 weeks after childbirth.
- Do not affect quantity and quality of breast milk.
- No oestrogen-related side effects. Do not increase risk of oestrogen-related complications such as heart attack or stroke.
- Women take one pill every day with no break. Easier to understand than taking 21-day combined pills.
- Can be very effective during breastfeeding.

Limitations

Some users report the following:

- Changes in bleeding patterns, including:
 - ◆ For breastfeeding women, longer delay in return of monthly bleeding after childbirth (lengthened postpartum amenorrhoea)
 - ◆ Irregular menstrual bleeding
 - ◆ Amenorrhoea
- Headaches
- Dizziness
- Mood changes
- Breast tenderness
- Abdominal pain
- Nausea
- For women not breastfeeding, enlarged ovarian follicles

Client Assessment as per World Health Organization Medical Eligibility Criteria for Progestin-Only Contraceptive Pills

1. Does the client have or has she ever had breast cancer?
If yes, do not provide POPs. Help her choose a method without hormones.
2. Does the client have jaundice, severe cirrhosis of the liver, a liver infection, or tumour?
Perform physical exam or refer. If she has serious active liver disease (jaundice, painful or enlarged liver, active viral hepatitis, liver tumour), do not provide POPs. Refer for care. Help her choose a method without hormones.
3. Is the client breastfeeding a baby younger than 6 weeks old?
She can start POP soon after birth. MEC Category 2
4. Does the client have serious problems with her blood vessels? If so, what problems?
Do not provide POPs if she reports blood clots (except superficial clots). Help her choose another effective method.
5. Is the client taking medicine for seizures? Taking rifampicin or griseofulvin?
If she is taking phenytoin, carbamazepine, barbiturates, or primidone for seizures or rifampicin or griseofulvin, provide condoms or spermicide or another contraceptive. If she prefers, or if she is on long-term treatment, help her choose another effective method.
6. Does the client think she is pregnant?
Assess whether pregnant. If she might be pregnant, give her condoms or spermicide to use until reasonably sure that she is not pregnant. Then she can start POPs.

Topic	MEC Recommendations
Recommendations for progestogen-only contraceptive (POC) and levonorgestrel-releasing intrauterine device (LNG-IUD) use among breastfeeding women	
POC use among breastfeeding women (POCs include progestogen-only pills, implants and injectables)	
< 6 weeks postpartum	Breastfeeding women who are < 6 weeks postpartum can generally use progestogen-only pills (POPs) (MEC Category 2). Breastfeeding women who are < 6 weeks postpartum generally should not use progestogen-only injectables (POIs) (MEC Category 3).
≥ 6 weeks to < 6 months postpartum	Breastfeeding women who are ≥ 6 weeks to < 6 months postpartum can use POPs, POIs, without restriction (MEC Category 1)
≥ 6 months postpartum	Breastfeeding women who are ≥ 6 months postpartum can use POPs, POIs without restriction (MEC Category 1).

Method of Use

Starting Time

POPs may be given to breastfeeding women:

- Soon after childbirth
- At any time after confirmation that she is not pregnant.
- If menstrual periods have returned, she can start POPs at any time it is reasonably certain that she is not pregnant.

POPs may be given to non-breastfeeding women:

- Soon after childbirth.

POCs may be started immediately post-abortion either after First trimester, second trimester or Immediate post-septic abortion

Technique

The client should always take one pill each day at approximately the same time for maximum efficacy, until the pill packet is finished. The more pills she misses, the greater her risk of becoming pregnant.

- When she finishes one pack, she should take the first pill from the next pack on the very next day.
- It is very important to start the next pack on time. Starting a pack late risks pregnancy.

Missed Pills

Instructions If a Woman Forgets to Take a Pill or Pills

It is easy to forget a pill or to be late in taking it. POP users should know what to do if they forget to take pills.

If a woman is 3 or more hours late in taking a pill or misses one completely, she should follow the instructions below:

For breastfeeding women, whether missing a pill places her at risk of pregnancy depends on whether or not her monthly bleeding has returned.

- Take a missed pill as soon as possible.
- Keep taking pills as usual, one each day. (She may take 2 pills at the same time or on the same day.)

If the client has regular monthly bleeding:

- Use a backup method for the next 2 days.
- Also, if she had sex in the past 5 days, she can consider taking ECs.

If she vomits within 2 hours after taking a pill:

- Take another pill from her pack as soon as possible, and keep taking pills as usual.
- If vomiting or diarrhoea continues, follow the instructions above for making up missed pills.

Table 8-2. Progestin-Only Pills: Side Effects and Their Management

Side Effect	Management
Nausea or dizziness	Take POPs at bedtime and with food.
Breast tenderness	
<ul style="list-style-type: none"> • Women not breastfeeding 	<ul style="list-style-type: none"> • Advise her to wear a supportive bra (including during strenuous activity and sleep). • Use hot or cold compresses. • Give her: <ul style="list-style-type: none"> – Tab. aspirin (325-650 mg), SOS but not more than three times a day – Tab. ibuprofen (200-400 mg), 1BD – Tab. paracetamol (325-1,000 mg), 1TDS <p>The number of tabs will depend on the formulation. The dosage can vary with the severity of the problem.</p>
Amenorrhoea	
<ul style="list-style-type: none"> • Breastfeeding women 	Reassure her that this is normal during breastfeeding. It is not harmful.
<ul style="list-style-type: none"> • Women not breastfeeding 	Reassure her that it is not harmful; in fact, lack of menstruation will help improve her anaemia.
Irregular bleeding	<ul style="list-style-type: none"> • Reassure her that it is not harmful. • Breastfeeding itself may cause irregular bleeding. • Many women using POPs experience irregular bleeding, whether breastfeeding or not: <ul style="list-style-type: none"> – Vomiting or diarrhoea might cause irregular bleeding. – Taking anticonvulsants or rifampicin might cause irregular bleeding. <p>To reduce irregular bleeding:</p> <ul style="list-style-type: none"> • Tell her to make up for missed pills properly, including after vomiting or diarrhoea. • For temporary relief: <ul style="list-style-type: none"> – Tab. ibuprofen 800 mg TDS after meals for 5 days, or – Tab. Ponstan 2TDS, beginning when irregular bleeding starts. • If even after taking medication condition does not improve, counsel her for another method.
<ul style="list-style-type: none"> • If irregular bleeding continues or starts after several months of normal or no monthly bleeding, or you suspect that something may be wrong for other reasons 	<ul style="list-style-type: none"> • Consider underlying conditions unrelated to method use. Refer. • Counsel for another suitable method if needed.

Side Effect	Management
Heavy or prolonged bleeding (twice as much as usual or longer than 8 days)	<ul style="list-style-type: none"> Reassure her that it is not harmful and usually lessens or stops after a few months. For temporary relief: <ul style="list-style-type: none"> Tab. ibuprofen 800 mg (max) TDS after meals for 5 days, or Tab. Ponstan 2TDS, beginning when irregular bleeding starts. Iron Tab. 1 TDS and eat foods containing iron. Consider underlying conditions unrelated to method use. Refer if necessary. Counsel for another suitable method if needed.
<ul style="list-style-type: none"> If heavy or prolonged bleeding continues or starts after several months of normal or no monthly bleeding 	Consider underlying conditions unrelated to method use.
Headache	<p>Give her:</p> <ul style="list-style-type: none"> Tab. aspirin (325-650 mg), 1TDS Tab. ibuprofen (200-400 mg), 1BD Tab. paracetamol (325-1,000 mg), 1TDS <p>The number of tabs will depend on the formulation. Dosage will vary according to the severity of the headache.</p>
<ul style="list-style-type: none"> Headaches that get worse or occur more often 	Counsel her for another suitable contraceptive method.
Depression or irritability	If confirmed to have happened after starting the pills, stop pills; give another suitable contraceptive method.
Loss of sexual desire	<p>If confirmed to have happened after starting pills:</p> <ul style="list-style-type: none"> Rule out local infections as a cause. Stop pills, and give another suitable contraceptive method.
Severe pain in lower abdomen	<p>Many conditions can cause severe abdominal pain. Check for signs and symptoms of ectopic pregnancy, which are:</p> <ul style="list-style-type: none"> Unusual abdominal pain or tenderness Abnormal vaginal bleeding or no monthly bleeding, especially if this is a change from her usual bleeding pattern Light-headedness or dizziness Fainting <p>If ectopic pregnancy or other serious health condition is suspected, refer at once for immediate diagnosis and care.</p>

Counselling

A client who chooses POPs can benefit from good counselling. A friendly provider who listens to a client's concerns, answers her questions, and gives clear, practical information helps the woman use POPs with success and satisfaction. Thorough counselling about bleeding changes and other side effects is an important part of providing the method. Counselling about menstrual changes may be the most important help a client needs to keep using the method.

The health care provider should follow these steps to provide POPs:

- Show the client the POP packet that she will use, even if she will be getting her pills elsewhere later.
- Explain that all pills in POP packets are the same white colour and all are active hormonal pills.
- Tell her about the advantages and limitations.
- Inform her about the common side effects and what to do.
- Give her a sufficient number of pills packets, depending on her need. Running out of pills is a major reason for unintended pregnancies.
- Explain how to use POPs and what to do if she misses pills.
- If possible, give her condoms or spermicide to use:
 - ◆ Until she can start taking her pills (if needed).
 - ◆ If she starts a packet of pills late, if she forgets several pills in a row, or if she stops taking oral contraceptives for any reason.
 - ◆ If she or her spouse are at risk of HIV/AIDS or any other STI, show her how to use condoms.
- Plan a return visit in time to give her more pills before her supply runs out.
- Invite the client to come back to the clinic at any time if she has questions, problems, or wants another method.
- Ask her to repeat the most important instructions and, using the pill packet, show her how she will take her pills.
- Ask her if she has any questions, fears, or concerns, and answer her concerns respectfully and caringly.
- For any unscheduled visit, ask her to bring the packet in use with her.

Follow-Up

The follow-up care and support of the client is very important for continued use of OCPs. The health care provider has a responsibility to keep the client satisfied, in case she has side effects, by providing correct information and reassurance.

Explain Specific Reasons to See a Trained Health Care Provider

Assure the client that she is welcome to come back at any time, especially if:

- She has problems, questions, or wants another method.
- She has a major change in health status.
- She thinks she might be pregnant.
- She has stopped breastfeeding and wants to switch to another method.

- She took a pill more than 3 hours late or missed one completely, and also had sex during this time; she may wish to consider ECPs.

She should immediately see a health care provider if she has any of the following warning signs.

Warning signs

- A=** Abnormal heavy bleeding
- S=** Stroke and heart disease (chest pain with dyspnoea)
- H=** Headache (severe)
- Y=** Yellow colour of eyes (jaundice)

Helping Clients at Any Return Visit

- Ask if the client has any questions or anything to discuss.
- Ask the client about her experience with the method, whether she is satisfied, and whether she has any problems. Give her any information or help that she needs and invite her to return again at any time she has questions or concerns. If she has problems that cannot be resolved, help her choose another suitable contraceptive method.

Plan for Next Visit

- Encourage her to come back for more pills before she uses up her supply of pills.

Minimum Record

Maintain the following record for follow-up of the client:

- Daily register
- Client record card
- Client card, to be given to the client with information such as:
 - ◆ Name, age and registration number
 - ◆ Type of POP given
 - ◆ Date for follow-up visit

Update records at each visit including details of complaints, side effects, and treatment given.

9

INJECTABLES

Introduction

Injectable contraceptives contain female hormones. These hormones are slowly released in a woman's body and provide protection against pregnancy. Two types of injectable contraceptives are available in Pakistan. These are:

- Progestin-only injectable contraceptives (PICs), which contain only progestin.
- Combined injectable contraceptives (CICs), which contain oestrogen as well as progesterone.

Policy

- Injectables will not be given to:
 - A woman who is pregnant or suspected to be pregnant.
 - Postpartum women before 6 weeks after childbirth if breastfeeding for Depo-Provera/ Megestron and Norgest, and 6 months postpartum for Mesigyna.
- Injectables can be given to women immediately after abortion on their request.
- Injectables will be provided by all health cadres approved and trained by the local provincial policy. Cadres include Doctors, Lady health visitors, Community midwives and Lady health workers.

Standards

The following standards must be maintained:

- Complete asepsis must be ensured while the injection is given.
- Use of disposable syringes should be made compulsory.
- All health care providers must be trained in the technique of administering injectables.

Progestin-Only Injectables

The injectable contraceptives DMPA (depot medroxyprogesterone acetate) and NET-EN (norethindrone enanthate) each contain synthetic progestin like the natural hormone progesterone that is in a woman's body.

DMPA

This progestin injectable contraceptive (PIC) contains depot medroxyprogesterone acetate and is prepared as a micro-crystalline suspension. A dose of 150 mg in 1 ml of the suspension is given by deep intramuscular injection at regular, 12-week intervals to protect the client from unwanted pregnancy. DMPA, the most widely used PIC, is also known as "the shot", "the jab", Depo, Depo-Provera, and Megestron.

According to MEC 2015 WHO has also introduced depot medroxyprogesterone acetate DMPA (104 mg/0.65 mL) subcutaneous injection at regular interval of 12 weeks.

DMPA-IM and DMPA-SC appear to be therapeutically equivalent; the two formulations demonstrate similar pharmacokinetics, effects on serum estradiol levels and high contraceptive efficacy. In addition, similar effects on weight change, bleeding patterns and experience of other adverse effects have been reported among healthy reproductive age users.

DMPA-SC does not protect against sexually transmitted infections (STIs), including HIV. If there is a risk of STI/HIV, the correct and consistent use of condoms is recommended. When used correctly and consistently, condoms offer one of the most effective methods of protection against STIs, including HIV. Female condoms are effective and safe, but are not used as widely by national programmes as male condoms.

A randomized trial evaluating changes in bone mineral density (BMD) among adult DMPA-SC and IM users demonstrated no differences at two years of follow-up. Limited evidence from three Phase 3 contraceptive trials reported no consistent differences in weight change or bleeding patterns according to age; adolescents aged < 18 years were not included in any studies. Two prospective, non-comparative studies demonstrated that women with endometriosis treated with DMPA-SC for six months experienced minimal weight gain and decreases in BMD; serious adverse events were rare and DMPA-SC improved pain symptoms associated with the condition. A randomized cross-over study reported that women living with HIV tolerated injection of DMPA-SC and that experiences of serious adverse events were rare and occurred at similar rates as in users of DMPA-IM. Evidence from three Phase 3 contraceptive trials and four reports from a small prospective cohort study reported similar contraceptive efficacy, weight change, bleeding patterns and other adverse effects, including variations in a number of biomarkers, among obese and non-obese DMPA-SC users.

DMPA can have different brand names or names that show how it is injected (IM or subcutaneous). Some of these names are:

- **Depo-Provera®**
- **depo-IM**
- **Sayana® Press.** It is a new formula of DMPA which is injected into the fatty tissues right under the skin (subcutaneously). They are available in Unijects. It has same characteristics as of Intra Muscular DMPA. The first injection of Sayana press is given by the trained health provider after proper screening. The reinjects can be done by the clients at home. However Self-administration procedure of injection should be

explained to the client in detail for storage, self-injection, disposal, danger signs and follow ups.

Feature	Depo IM	Sayana Press – S/C
Mg/dose	150 mg	104 mg
Package	Vial and syringe	Prefilled Uniject syringe
Type of injection	Intramuscular (deep into the muscle)	Subcutaneous (in the fatty tissue under the skin)
Where to inject	<ul style="list-style-type: none"> • Arm (deltoid muscle) • Hip • Buttocks 	<ul style="list-style-type: none"> • Anterior thigh (front of thigh) • Abdomen • Back of arm
Skin irritation	Skin irritation at injection site is not likely	Skin may be a little irritated at injection site

NET-EN

This PIC contains norethindrone enanthate and is prepared in an oily solution. A dose of 200 mg in 1 ml of oily solution is given by deep intramuscular injection regularly at 8-week intervals to protect the client from unwanted pregnancy.

Mode of Action

The progestin in the injectables acts as a contraceptive by:

- Inhibiting ovulation most of the time.
- Thickening cervical mucus to form a plug, which inhibits the transport of sperm.
- Making the endometrium less suitable for implantation of the fertilized ovum.

Effectiveness

- When women have injections on time, less than 1 pregnancy occurs per 100 women.
- As commonly used, about 3 pregnancies occur per 100 women.

Pregnancy rates may be higher for women who are late for an injection or who miss an injection, or if providers run out of supplies.

Advantages

- Very effective.
- Privacy-No one else can tell that a woman is using it.
- One injection prevents pregnancy for 2-3 months.
- Is reversible.
- Does not interfere with sex.
- Increased sexual enjoyment because no need to worry about pregnancy.
- No daily pill-taking.
- Allows some flexibility in return visit; client can return for next injection up to 4 weeks late for DMPA and 2 weeks late for NET-EN.
- Does not affect the quantity and quality of breast milk.
- Can be used by nursing mothers as soon as 6 weeks after childbirth.

- No oestrogen-related side effects.
- Helps prevent endometrial cancer.
- Helps prevent uterine fibroids.
- May help prevent ovarian cancer.
- Special advantages for some women:
 - May help prevent iron-deficiency anaemia.
 - Makes sickle cell crises less frequent and less painful.
- Reduces symptoms of endometriosis (pelvic pain, irregular bleeding).
- Protects against symptomatic pelvic inflammatory disease (PID).
- Women who are infected with HIV, have AIDS, or are on antiretroviral (ARV) therapy can safely use progestin-only injectables.

Limitations

- Menstrual changes like spotting and irregular bleeding are common in the first few months of use with both Norigest and Depo-Provera/Megestron.
- Amenorrhoea after prolonged use may occur.
- The return of fertility can be delayed after stopping the injection-an average of 10 months for DMPA and 6 months for NET-EN.
- Cannot be easily discontinued or removed from the body if complications develop or if pregnancy is desired.
- Does not protect against sexually transmitted infections (STIs), including HIV/ AIDS.

WHO MEC 2015 Recommendations

Age:

- Young women (menarche to < 18 years) can generally use DMPA (MEC Category 2).
- Women between the ages of 18 and 45 years can use DMPA without restriction (MEC Category 1)
- Women > 45 years old can generally use DMPA (MEC Category 2).

Endometriosis:

- Women with endometriosis can use DMPA without restriction (MEC Category 1).

HIV:

- Women living with HIV who have asymptomatic or mild clinical disease (WHO stage 1 or 2) can use DMPA without restriction (MEC Category 1).
- Women living with HIV who have severe or advanced HIV clinical disease (WHO stage 3 or 4) can use DMPA without restriction (MEC Category 1).

Obesity:

- Women with a body mass index (BMI) ≥ 30 kg/m² can use DMPA without restriction (MEC Category 1).
- Young women (menarche to < 18 years) with a BMI ≥ 30 kg/m² can generally use DMPA (MEC Category 2).

There is evidence for differential weight gain among normal-weight and obese adolescents who use DMPA, but not those using norethisterone enanthate (NET-EN). However, NET-EN is MEC Category 2 due to evidence regarding potential effects of NET-EN on bone mineral density among adolescents.

Client Assessment as per World Health Organization Medical Eligibility Criteria for Progestin-Only Injectables

Ask the client the questions given below. If the answer is “no” to all of the questions, then the client can use injectables. If the answer is “yes” to a question, follow the instructions.

1. Is the client breastfeeding a baby younger than 6 weeks old?
Start using injectables 6 weeks after childbirth. If fully or almost fully breastfeeding, she is protected from pregnancy for 6 months after childbirth or until her menstrual period returns. The client must begin contraception at once to avoid pregnancy. Encourage her to continue breastfeeding.
2. Does the client have problems with her heart or blood vessels? Has she ever had such problems? If so, what problems?
Do not provide injectables if the client reports heart attack, heart disease due to blocked arteries, stroke, blood clots (except superficial clots), severe chest pain with unusual shortness of breath, severe high blood pressure, diabetes for more than 20 years, or damage to vision, kidneys, or nervous system caused by diabetes. Help the client choose another effective method except combined hormonal contraceptives.
3. Does the client have high blood pressure?
If the client reports high blood pressure, check BP immediately. If systolic BP is over 160 or diastolic BP over 100, do not provide the injection. Help the client choose another method except combined oral contraceptive (COCs)/CICs.
4. Does the client have or has she ever had breast cancer?
Do not provide the injection. Help the client choose a method without hormones.
5. Does the client have severe cirrhosis of the liver, a liver infection, or tumour? (Are the client's eyes or skin unusually yellow?)
Perform physical examination or refer. If the client has serious active liver disease (jaundice, painful or enlarged liver, viral hepatitis, or liver tumour) do not provide the injection. Refer for care. Help the client choose a method without hormones.
6. Does the client think she is pregnant?
Assess whether pregnant. Give condoms to use until reasonably sure that pregnancy is excluded. Then the injection can be given.
7. Does the client have vaginal bleeding that is unusual for her?
If the client has unexplained vaginal bleeding that suggests an underlying medical condition, do not provide the injection. (PICs could make diagnosis and monitoring of any treatment difficult.) Assess and treat any underlying condition as appropriate, or refer. Help her to choose a suitable method while being evaluated and treated. After treatment, reevaluate for use of PICs. Be sure to explain the health benefits, risks, and the side effects of the method that the client will use. Also, point out any conditions that would make the method inadvisable.
8. Have you ever been told you have diabetes (high sugar in your blood)?
This question is intended to identify women who know that they have diabetes, not to assess whether they may have an undiagnosed condition. Women who have had diabetes for 20 years or longer, or those with vascular complications, should usually not use DMPA because of the increased risk of blood clots. Evaluate or refer for evaluation as appropriate and, if these complications are absent, the woman may still be a good candidate for DMPA
9. Have you ever been told that you have a rheumatic disease, such as lupus?
This question is intended to identify women who have been diagnosed with systemic lupus disease. Women who have systemic lupus disease and who are not on immunosuppressive treatment should usually not use DMPA, due to concerns about a possible increased risk of

Checklist for Screening Clients Who Want to Initiate DMPA (or NET-EN)

To determine if the client is medically eligible to use DMPA, ask questions 1-9. As soon as the client answers **YES** to **any question**, stop, and follow the instructions after question 9.

NO	1. Have you ever been told you have breast cancer?	YES
NO	2. Have you ever had a stroke or heart attack, or do you currently have a blood clot in your legs or lungs?	YES
NO	3. Do you have a serious liver disease or jaundice (yellow skin or eyes)?	YES
NO	4. Have you ever been told you have diabetes (high sugar in your blood)?	YES
NO	5. Have you ever been told you have high blood pressure?	YES
NO	6. Do you have bleeding between menstrual periods, which is unusual for you, or bleeding after intercourse (sex)?	YES
NO	7. Have you ever been told that you have a rheumatic disease such as lupus?	YES
NO	8. Do you have two or more conditions that could increase your chances of a heart attack or stroke, such as smoking, obesity, high blood pressure, or diabetes?	YES
NO		YES

If the client answered **YES** to **question 1**, she is not a good candidate for DMPA. Counsel about other available methods or refer.
 If the client answered **YES** to **any of questions 2–8**, DMPA cannot be initiated without further evaluation. Evaluate or refer as appropriate, and give condoms to use in the meantime. See explanations for more instructions.
 If the client answered **YES** to **question 9**, instruct her to return for DMPA as soon as possible after the baby is six weeks old.

Ask questions 10-15 to be reasonably sure that the client is not pregnant. As soon as the client answers **YES** to **any question**, stop, and follow the instructions after question 15.

YES	10. Did your last menstrual period start within the past 7 days?	NO
YES	11. Have you abstained from sexual intercourse since your last menstrual period or delivery?	NO
YES	12. Have you been using a reliable contraceptive method consistently and correctly since your last menstrual period or delivery?	NO
YES	13. Have you had a baby in the last 4 weeks?	NO
YES	14. Did you have a baby less than 6 months ago, are you fully or nearly--fully breastfeeding, and have you had no menstrual period since then?	NO
YES	15. Have you had a miscarriage or abortion in the last 7 days?	NO

If the client answered **YES** to **at least one of the questions 10-15** and she is free of signs or symptoms of pregnancy, you can be reasonably sure that she is not pregnant. The client can start DMPA now.

If the client began her last menstrual period within **the past 7 days**, she can start DMPA immediately. No additional contraceptive protection is needed.

If the client began her last menstrual period **more than 7 days ago**, she can **be given DMPA now**, but instruct her that she must **use condoms or abstain from sex for the next 7 days**. Give her condoms to use for next 7 days.

If the client answered **NO** to **all of questions 10-15**, pregnancy can not be ruled out using the checklist.

Rule out pregnancy by other means. Give her condoms to use until pregnancy can be ruled out.

Offer emergency contraception if every every unprotected sex act since last menses occurred within the last five days.

Method of Use

- Any time it is reasonably certain that the client is not pregnant. If she is not at risk of pregnancy (for example, has not had sex since her last menstrual period), she may start injections at any time she wants.
- During the first 7 days after menstrual bleeding begins, no backup method is needed for extra protection.
- If she is starting on or after day eight of her menstrual period, she should use condoms or avoid sex for the next 7 days. If possible, give her condoms or spermicides.
- If a woman is breastfeeding, she may start PICs as early as 6 weeks after childbirth.
- If she is switching from any other hormonal method, injectables can be given immediately.
- If switching from a non-hormonal contraceptive, and she is not menstruating at present, she should use a condom or avoid sex for the next 7 days. In the case of switching in the first 7 days of the menstrual period, no backup method is required.

Equipment and Supplies Needed for Injection

- One of the injectables
- Antiseptic and cotton wool
- 2- or 5-ml disposable syringe with disposable needle

Technique for Giving Injection

1. Wash hands with soap and water.
2. If injection site is dirty, clean it with a wet swab.
3. Shake vial gently for DMPA. No need to do it for NET-EN.
4. If vial is cold, warm to skin temperature by rubbing between palms before giving injection. Now fill syringe with full dose.
5. For I/M injection, insert sterile needle deep into the upper arm (deltoid muscle) or into buttocks (gluteal muscle, upper outer portion). Inject the contents of the syringe.
6. For S/C injection, gently pinch the skin at the injection site (arm, abdomen and thigh). The pinch is important to make sure that the needle is injected into the fat and not into the muscle. Insert the needle at 35 angle to the skin. Inject the content of the syringe.
7. Do not massage the injection site, as it causes the medicine to be absorbed too quickly.
8. Maintain the record of injections.

Figure 9-1. Injection Sites for Progestin-Only Injectables

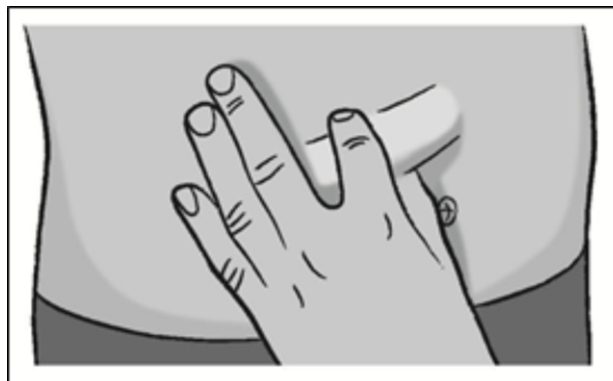

Table 9-1. Progestin-Only Injectables: Side Effects and Their Management

Side Effect	Management
Amenorrhoea (no monthly bleeding period)	<ul style="list-style-type: none"> • Is normal among injection users (especially DMPA) and not harmful. The client is not pregnant. Menstrual blood is not building up inside her. Instead, her body is not producing blood. • Explain that this can improve her health. It helps to prevent anaemia. • If not having monthly bleeding is bothering her, she may want to switch to monthly injectables, if available.
Spotting or bleeding between monthly periods	<ul style="list-style-type: none"> • Spotting or bleeding between periods is normal and very common during the first few months of injection use. It is not harmful. • If spotting or bleeding persists or follows a period of amenorrhoea, rule out gynaecological problems. • If a gynaecological problem is found, treat or refer. • If irregular bleeding is caused by STI or PID, continue injections. Treat the cause or refer. • For modest, short-term relief, take 800 mg (max) ibuprofen three times daily or 500 mg mefenamic acid three times daily after meals for 5 days, beginning when irregular bleeding starts. • If irregular bleeding continues, or starts after several months of normal or no monthly bleeding, or if it is suspected that something may be wrong for another reason, consider underlying conditions unrelated to method use.
Heavy or prolonged bleeding (more than 8 days long or twice as much as her usual menstrual period)	<p>Reassure her.</p> <ul style="list-style-type: none"> • For modest, short-term relief, a client can take: <ul style="list-style-type: none"> – Combined oral contraceptive (COCs), taking one pill daily for 21 days, beginning when heavy bleeding starts. – 50 mcg of ethinyl estradiol daily for 21 days, beginning when heavy bleeding starts. • If bleeding becomes a health threat or if the woman wants to switch methods, help her choose another method. • To prevent anaemia, suggest iron tablets and tell the woman it is important to eat foods that contain iron, such as meat, poultry, fish, green leafy vegetables, and legumes. • If heavy or prolonged bleeding continues or starts after several months of normal or no monthly bleeding, consider underlying conditions unrelated to method use.

Side Effect	Management
Unexplained abnormal vaginal bleeding that suggests pregnancy or an underlying medical condition	<ul style="list-style-type: none"> Refer or evaluate by history and pelvic examination. Diagnose and treat as appropriate. If no cause of bleeding can be found, consider stopping PICs to make diagnosis easier. Provide another method of her choice. If bleeding is caused by STIs or PID, she can continue using PICs during treatment.
Ordinary headaches	<ul style="list-style-type: none"> Suggest aspirin (325-650 mg), ibuprofen (200-400 mg), paracetamol (325-1,000 mg), or another pain reliever. Any headaches that get worse or occur more often should be evaluated.
Migraine headaches	<ul style="list-style-type: none"> If a woman has migraine headaches without aura, she can continue to use the method if she desires. If she has migraine with aura, do not give the injection. Help her choose a method without hormones.
Mood changes	<ul style="list-style-type: none"> Ask about changes in her life that could affect her mood, including her relationship with her partner. Give support as appropriate. Refer clients who have serious mood changes such as major depression.

Method-Specific Counselling

Pre-Procedure Counselling

After greeting the client and making her comfortable, ask questions to confirm that she needs a contraceptive for long-term use.

Give the following information:

- Tell the client that there are two types of injectables.
- Show the client the injection ampoule and disposable syringe.
- Explain how the injection acts as a contraceptive. Explain its method of use.
- Tell the client about advantages and limitations.
- Discuss doubts and fears that the client may have and help dispel these by providing adequate information.
- Answer any questions the client asks.

Post-Procedure Counselling

Give information to the client regarding the schedule for follow-up, possible side-effects, and their management.

Schedule for Next Injection

Give the following information to the clients:

- Acceptors of injection NET-EN should report for the next injection after exactly 8 weeks. However, it can be given within 2 weeks earlier or later.
- Acceptors of injection DMPA should report for the next injection after exactly 12 weeks. However, it can be given 4 weeks earlier or later.
- The client can come at any time in case of any problem.

Combined Injectable Contraceptives

Combined injectable contraceptives (CICs) are also called monthly injectables. They contain two hormones—a progestin and an oestrogen. In contrast, PICs contain progestin only. These differences result in more regular bleeding and fewer bleeding disturbances than with PICs.

Mesigyna: This CIC contains both norethindrone enanthate (NET-EN) 50 mg and estradiol valerate 5 mg in 1 ml of oily solution, and provides protection for 4 weeks.

Mode of Action

Works primarily by inhibiting ovulation.

Effectiveness

Effectiveness depends on the client's returning on time: Risk of pregnancy is greatest when a woman is late for an injection or misses an injection:

- When women have injections on time, less than 1 pregnancy occurs per 100 women using monthly injectables over the first year (5 per 10,000 women).
- As commonly used, about 3 pregnancies occur per 100 women using monthly injectables over the first year. This means that 97 of every 100 women using monthly injectables will not become pregnant.

Advantages

- Most of the advantages are the same as those for PICs.
- Return of fertility may be delayed, but the delay is less than with PICs. Women can become pregnant on an average of 5 months after their last injection.

Limitations

Long-term studies of monthly injectables are limited, but researchers expect that their health risks are similar to those of COCs.

- Some user reports the following:
 - Changes in bleeding patterns including infrequent bleeding, amenorrhoea, or prolonged bleeding
 - Breast tenderness
 - Headache, dizziness
 - Weight gain
- CICs require frequent clinic visits after 4 weeks.
- There is less flexibility in case of late injection (1 week only).
- Cannot be used by breastfeeding mothers before 6 months postpartum.

Client Assessment as per World Health Organization Medical Eligibility Criteria for Combined Injectable Contraceptives

Ask the client the questions given below about any known medical conditions. If she answers "no" to all of the questions, then she can start monthly injectables if she wants. If she answers "yes" to a question, follow the instructions. In some cases she can still start monthly injectables.

1. Is she breastfeeding a baby younger than 6 months old?
 - If fully or nearly fully breastfeeding: She can start 6 months after giving birth or when breast milk is no longer the baby's main food- whichever comes first.
 - If partially breastfeeding: She can start monthly injectables as soon as 6 weeks after giving birth.
2. Has she had a baby in the last 3 weeks and is not breastfeeding?
She can start monthly injectables as soon as 3 weeks after childbirth.
3. Does she smoke 15 or more cigarettes a day?
If she is 35 years of age or older and smokes more than 15 cigarettes a day, do not provide monthly injectables. Urge her to stop smoking and help her choose another method.
4. Does she have severe cirrhosis of the liver, a liver infection, or liver tumour? (Are her eyes or skin unusually yellow? [signs of jaundice])
If she reports serious active liver disease (jaundice, active hepatitis, severe cirrhosis, liver tumour), do not provide monthly injectables. Help her choose a method without hormones. (If she has mild cirrhosis or gall bladder disease, she can use monthly injectables.)
5. Does she have high blood pressure?
If you cannot check her blood pressure and she reports a history of high blood pressure, or if she is being treated for high blood pressure, do not provide monthly injectables. Refer her for a blood pressure check if possible or help her choose another method without oestrogen.
Check her blood pressure if possible:
 - If blood pressure is below 140/90 mm Hg, provide monthly injectables.
 - If systolic blood pressure is 140 mm Hg or higher or diastolic blood pressure is 90 or higher, do not provide monthly injectables. Help her choose a method without oestrogen, but not PICs if systolic blood pressure is 160 or higher or diastolic pressure is 100 or higher.

Client Assessment as per World Health Organization Medical Eligibility Criteria for Combined Injectable Contraceptives

(One blood pressure reading in the range of 140–159/90–99 mm Hg is not enough to diagnose high blood pressure. Provide a backup method to use until she can return for another blood pressure check, or help her choose another method now if she prefers. If blood pressure at next check is below 140/90, she can use monthly injectables.)

6. Has she had diabetes for more than 20 years or damage to her arteries, vision, kidneys, or nervous system caused by diabetes?

Do not provide monthly injectables. Help her choose a method without oestrogen but not progestin-only injectables.

7. Has she ever had a stroke, blood clot in her legs or lungs, heart attack, or other serious heart problems?

If she reports heart attack, heart disease due to blocked or narrowed arteries, or stroke, do not provide monthly injectables. Help her choose a method without oestrogen, but not PICs. If she reports a current blood clot in the deep veins of the leg or in the lung (not superficial clots), help her choose a method without hormones.

8. Does she have or has she ever had breast cancer?

Do not provide monthly injectables. Help her choose a method without hormones.

9. Does she sometimes see a bright area of lost vision in the eye before a very bad headache (migraine aura)? Does she get throbbing, severe head pain, often on one side of the head, that can last from a few hours to several days and can cause nausea or vomiting (migraine headaches)?

If she has migraine aura at any age, do not provide monthly injectables. If she has migraine headaches without aura and is age 35 or older, do not provide monthly injectables. Help these women choose a method without oestrogen. If she is under 35 and has migraine headaches without aura, she can use monthly injectables.

10. Is she planning major surgery that will keep her from walking for 1 week or more?

If so, she can start monthly injectables 2 weeks after the surgery. Until she can start monthly injectables, she should use a backup method.

11. Does she have several conditions that could increase her chances of heart disease (coronary artery disease) or stroke, such as older age, smoking, high blood pressure, or diabetes?

Do not provide monthly injectables. Help her choose a method without oestrogen, but not PICs.

Method of Use

The method of use for CICs is the same as for PICs, with the following exceptions:

- If a woman is fully or nearly fully breastfeeding, then she may start the method after 6 months postpartum or when breast milk is no longer the baby's main food-whichever comes first.
- If more than 6 months postpartum and she does not have monthly bleeding, she can start injectables at any time it is reasonably certain that she is not pregnant. She will need a backup method for the first 7 days after the injection.
- If she is partially breastfeeding, the first injection should be delayed until 6 weeks postpartum.

- Non-breastfeeding mothers can start CICs at any time on days 21-28 postpartum. No need for a backup method.
- If she is more than 4 weeks postpartum with no monthly bleeding, she can start CICs at any time if it is reasonably certain she is not pregnant. She will need a backup method for the first 7 days after the injection.
- After miscarriage or abortion, a woman can start CICs immediately or within 7 days after first or second trimester abortion. No need for backup method. If more than 7 days postabortion, she can start injection any time after pregnancy is excluded, but will need a backup method for the first 7 days after the injection.
- After taking emergency contraceptive pills (ECPs), she can start a CIC on the same day. There is no need to wait for the next monthly bleeding. She will need a backup method for the first 7 days after the injection.

Managing Late Injection

- If the client is less than 7 days late for a repeat injection, she can receive her next injection. There is no need for tests, evaluation, or a backup method.
- A client who is more than 7 days late can receive her next injection if:
 - She has not had sex since 7 days after she should have had her last injection, or
 - She has used a backup method or has taken ECPs after any unprotected sex since 7 days after she should have had her last injection.
 - She will need a backup method for the first 7 days after the injection.
- If the client is more than 7 days late and does not meet these criteria, additional steps can be taken to be reasonably certain she is not pregnant.
- Discuss why the client was late and ways to avoid this happening again. If coming back on time is often a problem, discuss using a backup method when she is late for her next injection, taking ECPs, or choosing another method.

Technique for Giving Injection

The technique for giving the injection is the same as that for NET-EN except it can be given deep into the anterior outer thigh as well.

Figure 9-2. Injection Sites for Combined Injectable Contraceptives

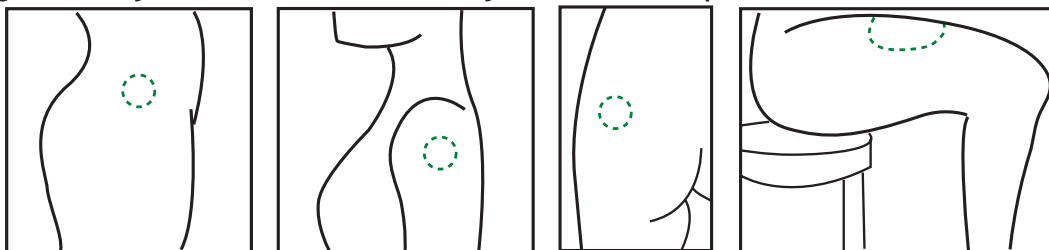

Table 9-2. Combined (Monthly) Injectables: Side Effects and Their Management

Side Effects	Management
Irregular bleeding	Same as PIC
Prolonged bleeding	Same as PIC
No monthly bleeding	Same as PIC
Headache	Same as PIC
Dizziness	Same as PIC
Weight gain	Same as PIC
Breast tenderness	<ul style="list-style-type: none"> Advise the client to wear supportive bra (including during strenuous activity and sleep). Give pain killer (aspirin, paracetamol, or ibuprofen).

Method-Specific Counselling

Pre-Procedure Counselling

After greeting the client and making her comfortable, ask questions to confirm that she needs a contraceptive for long-term use.

Give the following information:

- Show the client the injection ampoule and disposable syringe.
- Explain how the injection acts as a contraceptive.
- Explain its method of use.
- Tell the client about advantages and limitations.
- Discuss doubts and fears that the client may have and help dispel these by providing adequate information.
- Answer any questions the client asks.

Post-Procedure Counselling

Give information to the client regarding the schedule for follow-up, possible side-effects, and their management.

Schedule for Next Injection

She should report for the next injection after 4 weeks. However, she can receive her injection 7 days earlier or later.

Follow-Up

Ask the following questions at any return visit:

- Ask the client if she has any questions or anything to discuss.
- Ask the client about her experience with the method, whether she is satisfied, and whether she has any problems. Give her any information or help that she needs and invite her to return any time she has questions or concerns. If she has problems that cannot be resolved, help her choose another method.

- Ask about her bleeding patterns.
- Ask if she has had any health problems since her last visit:
- If the client has developed heart disease due to blocked arteries, stroke, blood clots (except superficial clots), breast cancer, severe high blood pressure, migraine, or active liver disease, help her choose a method without hormones.

Recordkeeping

Maintain the following minimum information for proper follow-up of the client:

- Daily client register.
- Client record card: record information about age, weight, parity, menstrual history, and findings of physical examination.
- Injection diary especially prepared and supplied for the purpose. Note the client's name, address, date of first injection, and also due date for the next injection.
- Client card: give this card to the client after entering on it her name, address, registration number, particulars of the contraceptive given, and the follow-up date.

Update all records after each follow-up visit, including details of complaints or side effects and treatment given, as per policy.

10

INTRAUTERINE CONTRACEPTIVE DEVICE (IUCD)

Introduction

Intrauterine contraceptive devices (also referred to as IUCDs) have been used by women in Pakistan since 1965, when the government-sponsored family planning (FP) program was launched. The IUCD is suitable and convenient for birth spacing. Once inserted, it is effective for 5-12 years.

The types now most widely used are copper-bearing IUCDs made of plastic with copper sleeves/copper wire on the plastic, for example, the CuT-380A and Multiload Cu-375; and hormone-containing IUCDs, such as the levonorgestrel intrauterine system (LNG-IUS).

Copper-Bearing IUCD	Hormone-Containing IUCD
<ul style="list-style-type: none"> • CuT-380A • MLCu-375 	Levonorgestrel intrauterine system (LNG-IUS)

Policy

- The IUCD will be inserted by a medical or paramedical health care providers (LHV, CMW, FWW) who are trained in its insertion/removal technique.
- IUCD insertion will be performed in a facility or camps that has acceptable standards of asepsis and infection control.

Standards

The following standards should be maintained:

- The client seeking the IUCD should be provided with all necessary information regarding advantages, effectiveness, limitations, side effects, and warning signs of the IUCD. The procedure for its insertion and removal must be fully explained.
- The health care provider must refer the client to a doctor if:
 - Perforation is suspected.

- Pregnancy occurs with the IUCD in place.
- There are symptoms or signs of pelvic inflammatory disease (PID).

Copper-Bearing Intrauterine Contraceptive Devices

Mode of Action

- Prevents fertilization, primarily by interfering with the ability of sperm to survive and fertilized.
- Alters or inhibits sperm migration, ovum transport, and fertilization.
- Creates a sterile foreign-body reaction in the endometrium, which is potentiated by copper ions.

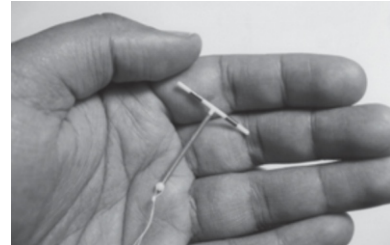

Effectiveness

The CuT-380A is effective for 12 years and the MLCu-375 is effective for 5 years. The copper IUCD is one of the most effective and long-lasting methods of contraception. Less than 1 pregnancy per 100 women using an IUCD occurs over the first year (6-8 pregnancies per 1,000 women). This means that 992-994 of every 1,000 women using IUCDs will not become pregnant.

A small risk of pregnancy remains beyond the first year of use and continues as long as the woman is using the IUCD. Over 10 years of IUCD use, there would be about 2 pregnancies per 100 women.

Types of IUCD Insertion according to timings

According to the timing of insertion, IUCD is divided into two types

- **PPIUCD:** It is the insertion of IUCD after the delivery of the baby. (For details Referred to Chapter 15 Postpartum Family Planning)

The three types of PPIUCD insertion are:

- **Postplacental:** Immediately within 10 minutes following the delivery of the placenta (active management of the third stage of labor [AMTSL] must be followed) in a vaginal birth, the IUCD is inserted with an instrument Kelly forceps before the woman leaves the delivery room.
- **Intracesarean:** Immediately following the removal of the placenta during a cesarean section, the IUCD is inserted manually or with sponge holding forceps before closure of the uterine incision, before the woman leaves the operating theater.
- **Early postpartum:** Not immediately following the delivery/removal of the placenta but within 2 days/48 hours of the birth (preferably within 24 hours, such as on the morning of postpartum Day 1), the IUCD is inserted with an instrument Kelly forceps during a separate procedure.
- **INTERVAL IUCD:** IUCDs inserted at 4 weeks postpartum and beyond are considered interval IUCDs.

The IUCD should not be inserted between 48 hours and 4 weeks postpartum because of an overall increase in the risk of complications, especially infection and expulsion. IUCDs inserted at 4 weeks postpartum and beyond are considered interval IUCDs, rather than PPIUCDs, because the same technique and services are required.

Advantages

- A single decision leads to effective, long-term prevention of pregnancy.
- Very effective.
- No interference with sex.
- Increased sexual enjoyment because no need to worry about pregnancy.
- Immediately reversible. After removal, pregnancy can occur as quickly as in women who have not used IUCDs.
- Has no effect on lactation. Can be inserted immediately after childbirth or after abortions (if no evidence of infection).
- Can be used through menopause (1 year or so after last menstrual period).
- No interactions with any medicines.
- Reduces the risk of ectopic pregnancy (less risk of ectopic pregnancy than in women not using any FP method).

Limitations

- Changes in bleeding pattern, especially in the first 3–6 months, but likely to lessen after 3 months of use:
 - Longer and heavier menstrual periods
 - Irregular bleeding or spotting between periods
 - More cramps or pain during periods
 - May contribute to anaemia, if the woman has low iron blood stores before insertion and IUCD causes heavier monthly bleeding
- If IUCD is properly inserted, perforation of the wall of the uterus is rare.
- Does not protect against sexually transmitted infections (STIs) including HIV/ AIDS.
- Client cannot stop IUCD use on her own. A trained health care provider is required for removal.
- May come out of the uterus, without the woman's knowledge.

Client Assessment as per organization Medical
Eligibility Criteria for IUCD

Ask the client the questions below. If she answers “no” to all of the questions, then the IUCD can be inserted if she wants. If she answers “yes” to a question below, follow the instructions:

1. Does the client think she is pregnant?
Assess whether pregnant. Do not insert the IUCD. Give her condoms or spermicide to use until reasonably sure that she is not pregnant.
2. Does the client have vaginal bleeding that is unusual for her?
If she has unexplained vaginal bleeding that suggests pregnancy or an underlying medical condition, use of an IUCD could make diagnosis and monitoring of any treatment more difficult. Help her choose a method to use while being evaluated and treated (but not a hormonal IUCD, progestin-only injectables, or implants). After treatment, re-evaluate for IUCD use.
3. Did the client give birth more than 48 hours but less than 4 weeks ago?
Delay inserting an IUCD until 4 or more weeks after childbirth. If needed, give her condoms or Implants can be offered.
4. Does she have an infection following childbirth or abortion?
If she currently has infection of the reproductive organs during the first 6 weeks after childbirth (puerperal sepsis) or she just had an abortion-related infection in the uterus (septic abortion), do not insert the IUCD. Treat or refer her if she is not already receiving care. Help her choose another method or offer a backup method. After treatment, re-evaluate for IUCD use.
Note: Assure confidentiality before asking the remaining questions.
5. Has the client had a sexually transmitted infection (STI) or pelvic inflammatory disease (PID) in the last 3 months? Does she have an STI, PID, or any other infection in the reproductive organs now? (Signs and symptoms of PID: severe pelvic infection with pain in lower abdomen and possibly also abnormal vaginal discharge, fever, or frequent urination with burning.) If she has no tenderness in the abdomen or when the cervix is moved, however, she probably does not have pelvic infection.
Women who have a very high individual likelihood of exposure to gonorrhoea or chlamydia should not have an IUCD inserted. Do not insert the IUCD now. Advise her to use condoms for STI protection. Treat or refer the client and her spouse. The IUCD can be inserted 3 months after cure unless re-infection is likely.
6. Does the client have HIV positive clinical or nonclinical disease.
Do not insert an IUCD if she has AIDS unless she is clinically well on antiretroviral therapy. If she is infected with HIV but does not have AIDS, she can use an IUCD. If a woman who has an IUCD in place develops AIDS, she can keep the IUCD. Whatever method she chooses, advise condom use. Give her male/ female condoms.
7. Does she think that she might get an STI in the future
A woman who has a very high individual likelihood of STIs should not have an IUCD inserted. Advise her to use condoms and help her chose another method.
8. Does she have cancer or tuberculosis of the female reproductive organs?
In case of known cervical, endometrial, or ovarian cancer; benign or malignant trophoblast disease; or pelvic tuberculosis: Do not insert an IUCD. Treat or refer her

for care as appropriate. Help her choose another effective method.
 Be sure to explain the health benefits, risks, and side effects of the method that the client will use. Also, point out any conditions that would make the method inadvisable for the client.

Characteristics and Conditions

Characteristics and conditions listed below are in World Health Organization (WHO) Eligibility Criteria category 1. Women with characteristics and conditions in WHO category 2 also can use this method. With proper counselling, women of any age or with any number of children can use the IUCD. (Age under 20 and having no children are characteristics in WHO Eligibility Criteria category 2.)

INTRAUTERINE DEVICES (IUDs)			
IUDs do not protect against sexually transmitted infections (STIs), including HIV. If there is a risk of STI/HIV, the correct and consistent use of condoms is recommended. When used correctly and consistently, condoms offer one of the most effective methods of protection against STIs, including HIV. Female condoms are effective and safe, but are not used as widely by national programmes as male condoms.			
CONDITION	CATEGORY		CLARIFICATIONS/EVIDENCE
	I = initiation, C = continuation		
	Cu-IUD	LNG-IUD	
† recommendations reviewed for the MEC 5th edition, further details after this table * additional comments after this table	Cu-IUD = copper-bearing IUD LNG-IUD = levonorgestrel-releasing IUD (20 µg/24 hours)		
PERSONAL CHARACTERISTICS AND REPRODUCTIVE HISTORY			
PREGNANCY	4	4	Clarification: The IUD is not indicated during pregnancy and should not be used because of the risk of serious pelvic infection and septic spontaneous abortion.
AGE			Evidence: Risks of pregnancy, infection and perforation are low among IUD users of any age. Heavy bleeding or removals for bleeding do not seem to be associated with age. Young women using Cu-IUDs may have an increased risk of expulsion compared with older Cu-IUD users (1–15).
a) Menarche to < 20 years	2	2	
b) ≥ 20 years	1	1	
PARITY			Evidence: Risks of pregnancy, infection, perforation and expulsion are low among all IUD users, and differences by parity may not be clinically meaningful. Data do not suggest an increased delay in return to fertility for nulliparous IUD users (1, 3, 7–10).
a) Nulliparous	2	2	
b) Parous	1	1	

INTRAUTERINE DEVICES (IUDs)

IUDs do not protect against sexually transmitted infections (STIs), including HIV. If there is a risk of STI/HIV, the correct and consistent use of condoms is recommended. When used correctly and consistently, condoms offer one of the most effective methods of protection against STIs, including HIV. Female condoms are effective and safe, but are not used as widely by national programmes as male condoms.

CONDITION	CATEGORY		CLARIFICATIONS/EVIDENCE
	I = initiation, C = continuation		
	Cu-IUD	LNG-IUD	
† recommendations reviewed for the MEC 5th edition, further details after this table * additional comments after this table	Cu-IUD = copper-bearing IUD LNG-IUD = levonorgestrel-releasing IUD (20 µg/24 hours)		
POSTPARTUM † (breastfeeding or non-breastfeeding women, including caesarean section)			Evidence: Immediate postpartum Cu-IUD insertion, particularly when insertion occurs immediately after delivery of the placenta, is associated with lower expulsion rates than delayed postpartum insertion. Additionally, post-placental placement at the time of caesarean section has lower expulsion rates than post-placental vaginal insertions. Insertion complications of perforation and infection are not increased by IUD placement at any time during the postpartum period (16–29). One randomized controlled trial found that immediate insertion of the LNG-IUD was associated with decreased breastfeeding duration compared with delayed insertion (30). Two other randomized controlled trials assessing early vs delayed initiation of progestogen-only contraceptives failed to show a difference in breastfeeding outcomes (31, 32). In other studies, initiation of LNG-IUD at 4 weeks postpartum or later demonstrated no detrimental effect on breastfeeding outcomes (33–35).
a) < 48 hours including insertion immediately after delivery of the placenta			
i) breastfeeding	1	2	
ii) non-breastfeeding	1	1	
b) ≥ 48 hours to < 4 weeks	3	3	
c) ≥ 4 weeks	1	1	
d) Puerperal sepsis	4	4	

INTRAUTERINE DEVICES (IUDs)			
IUDs do not protect against sexually transmitted infections (STIs), including HIV. If there is a risk of STI/HIV, the correct and consistent use of condoms is recommended. When used correctly and consistently, condoms offer one of the most effective methods of protection against STIs, including HIV. Female condoms are effective and safe, but are not used as widely by national programmes as male condoms.			
CONDITION	CATEGORY		CLARIFICATIONS/EVIDENCE
	I = initiation, C = continuation		
	Cu-IUD	LNG-IUD	
† recommendations reviewed for the MEC 5th edition, further details after this table * additional comments after this table	Cu-IUD = copper-bearing IUD LNG-IUD = levonorgestrel-releasing IUD (20 µg/24 hours)		
POST-ABORTION*			
a) First trimester	1	1	Clarification: IUDs can be inserted immediately after first-trimester, spontaneous or induced abortion. Evidence: There was no difference in risk of complications for immediate vs delayed insertion of an IUD after abortion. Expulsion was greater when an IUD was inserted following a second-trimester abortion vs a first-trimester abortion. There were no differences in safety or expulsions for post-abortion insertion of an LNG-IUD compared with a Cu-IUD (36–48).
b) Second trimester	2	2	
c) Immediate post-septic abortion	4	4	
PAST ECTOPIC PREGNANCY*	1	1	
HISTORY OF PELVIC SURGERY (see postpartum, including caesarean section)	1	1	
SMOKING			
a) Age < 35 years	1	1	
b) Age ≥ 35 years			
i) < 15 cigarettes/day	1	1	
ii) ≥ 15 cigarettes/day	1	1	
OBESITY			
a) ≥ 30 kg/m ² BMI	1	1	
b) Menarche to < 18 years and ≥ 30 kg/m ² BMI	1	1	
BLOOD PRESSURE MEASUREMENT UNAVAILABLE	NA	NA	NA = not applicable Clarification: While a blood pressure measurement may be appropriate for good preventive health care, it is not materially related to safe and effective IUD use. Women should not be denied use of IUDs simply because their blood pressure cannot be measured.

INTRAUTERINE DEVICES (IUDs)			
IUDs do not protect against sexually transmitted infections (STIs), including HIV. If there is a risk of STI/HIV, the correct and consistent use of condoms is recommended. When used correctly and consistently, condoms offer one of the most effective methods of protection against STIs, including HIV. Female condoms are effective and safe, but are not used as widely by national programmes as male condoms.			
CONDITION	CATEGORY I = initiation, C = continuation		CLARIFICATIONS/EVIDENCE
	Cu-IUD	LNG-IUD	
† recommendations reviewed for the MEC 5th edition, further details after this table * additional comments after this table	Cu-IUD = copper-bearing IUD LNG-IUD = levonorgestrel-releasing IUD (20 µg/24 hours)		
CARDIOVASCULAR DISEASE			
MULTIPLE RISK FACTORS FOR ARTERIAL CARDIOVASCULAR DISEASE (such as older age, smoking, diabetes, hypertension and known dyslipidaemias)	1	2	
HYPERTENSION* For all categories of hypertension, classifications are based on the assumption that no other risk factors for cardiovascular disease exist. When multiple risk factors do exist, the risk of cardiovascular disease may increase substantially. A single reading of blood pressure level is not sufficient to classify a woman as hypertensive.			
a) History of hypertension, where blood pressure CANNOT be evaluated (including hypertension in pregnancy)	1	2	
b) Adequately controlled hypertension, where blood pressure CAN be evaluated	1	1	
c) Elevated blood pressure levels (properly taken measurements)			
i) systolic 140–159 or diastolic 90–99 mm Hg	1	1	
ii) systolic ≥ 160 or diastolic ≥ 100 mm Hg	1	2	
d) Vascular disease	1	2	
HISTORY OF HIGH BLOOD PRESSURE DURING PREGNANCY (where current blood pressure is measurable and normal)	1	1	

INTRAUTERINE DEVICES (IUDs)			
IUDs do not protect against sexually transmitted infections (STIs), including HIV. If there is a risk of STI/HIV, the correct and consistent use of condoms is recommended. When used correctly and consistently, condoms offer one of the most effective methods of protection against STIs, including HIV. Female condoms are effective and safe, but are not used as widely by national programmes as male condoms.			
CONDITION	CATEGORY		CLARIFICATIONS/EVIDENCE
	I = initiation, C = continuation		
	Cu-IUD	LNG-IUD	
† recommendations reviewed for the MEC 5th edition, further details after this table * additional comments after this table	Cu-IUD = copper-bearing IUD LNG-IUD = levonorgestrel-releasing IUD (20 µg/24 hours)		
DEEP VEIN THROMBOSIS (DVT)/ PULMONARY EMBOLISM (PE)*			
a) History of DVT/PE	1	2	Evidence: Although evidence on the risk of venous thrombosis with the use of progestogen-only contraceptives (POCs) is inconsistent, any small increased risk is substantially less than that with combined oral contraceptives (COCs) (49–51).
b) Acute DVT/PE	1	3	
c) DVT/PE and established on anticoagulant therapy	1	2	
d) Family history (first-degree relatives)	1	1	
e) Major surgery			
i) with prolonged immobilization	1	2	
ii) without prolonged immobilization	1	1	
f) Minor surgery without immobilization	1	1	Evidence: Although evidence on the risk of venous thrombosis with the use of POCs is inconsistent, any small increased risk is substantially less than that with COCs (49–51). Limited evidence indicates that insertion of the LNG-IUD does not pose major bleeding risks in women on chronic anticoagulant therapy (52–54).
KNOWN THROMBOGENIC MUTATIONS (e.g. factor V Leiden; prothrombin mutation; protein S, protein C, and antithrombin deficiencies)	1	2	Clarification: Routine screening is not appropriate because of the rarity of the conditions and the high cost of screening.
SUPERFICIAL VENOUS DISORDERS			
a) Varicose veins	1	1	
b) Superficial venous thrombosis	1	1	

INTRAUTERINE DEVICES (IUDs)				
IUDs do not protect against sexually transmitted infections (STIs), including HIV. If there is a risk of STI/HIV, the correct and consistent use of condoms is recommended. When used correctly and consistently, condoms offer one of the most effective methods of protection against STIs, including HIV. Female condoms are effective and safe, but are not used as widely by national programmes as male condoms.				
CONDITION	CATEGORY I = initiation, C = continuation			CLARIFICATIONS/EVIDENCE
	Cu-IUD	LNG-IUD		
† recommendations reviewed for the MEC 5th edition, further details after this table * additional comments after this table	Cu-IUD = copper-bearing IUD LNG-IUD = levonorgestrel-releasing IUD (20 µg/24 hours)			
CURRENT AND HISTORY OF ISCHAEMIC HEART DISEASE*	1	I 2	C 3	
STROKE* (history of cerebrovascular accident)	1	2		
KNOWN DYSLIPIDAEMIAS WITHOUT OTHER KNOWN CARDIOVASCULAR RISK FACTORS	1	2		Clarification: Routine screening is not appropriate because of the rarity of the condition and the high cost of screening.
VALVULAR HEART DISEASE				
a) Uncomplicated	1	1		Clarification: Prophylactic antibiotics to prevent endocarditis are advised for insertion.
b) Complicated (pulmonary hypertension, risk of atrial fibrillation, history of subacute bacterial endocarditis)	2	2		
RHEUMATIC DISEASES				
SYSTEMIC LUPUS ERYTHEMATOSUS (SLE) People with SLE are at increased risk of ischaemic heart disease, stroke and venous thromboembolism. Categories assigned to such conditions in the Medical eligibility criteria for contraceptive use should be the same for women with SLE who present with these conditions. For all categories of SLE, classifications are based on the assumption that no other risk factors for cardiovascular disease are present; these classifications must be modified in the presence of such risk factors. Available evidence indicates that many women with SLE can be considered good candidates for most contraceptive methods, including hormonal contraceptives (54–71).				
a) Positive (or unknown) antiphospholipid antibodies	I 1	C 1	3	Evidence: Antiphospholipid antibodies are associated with a higher risk for both arterial and venous thrombosis (72, 73).
b) Severe thrombocytopenia	3	2	2	Clarification: Severe thrombocytopenia increases the risk of bleeding. The category should be assessed according to the severity of the thrombocytopenia and its clinical manifestations. In women with very severe thrombocytopenia who are at risk for spontaneous bleeding, consultation with a specialist and certain pretreatments may be warranted. Evidence: The LNG-IUD may be a useful treatment for menorrhagia in women with severe thrombocytopenia (54).

INTRAUTERINE DEVICES (IUDs)				
IUDs do not protect against sexually transmitted infections (STIs), including HIV. If there is a risk of STI/HIV, the correct and consistent use of condoms is recommended. When used correctly and consistently, condoms offer one of the most effective methods of protection against STIs, including HIV. Female condoms are effective and safe, but are not used as widely by national programmes as male condoms.				
CONDITION	CATEGORY			CLARIFICATIONS/EVIDENCE
	I = initiation, C = continuation			
	Cu-IUD	LNG-IUD		
† recommendations reviewed for the MEC 5th edition, further details after this table * additional comments after this table	Cu-IUD = copper-bearing IUD LNG-IUD = levonorgestrel-releasing IUD (20 µg/24 hours)			
c) Immunosuppressive treatment	2	1	2	
d) None of the above	1	1	2	
NEUROLOGIC CONDITIONS				
HEADACHES*		I	C	Clarification: Any new headaches or marked changes in headaches should be evaluated.
a) Non-migrainous (mild or severe)	1	1	1	
b) Migraine				
i) without aura				
age < 35 years	1	2	2	
age > 35 years	1	2	2	
ii) with aura, at any age	1	2	3	
EPILEPSY	1	1		
DEPRESSIVE DISORDERS				
DEPRESSIVE DISORDERS	1	1		Clarification: The classification is based on data for women with selected depressive disorders. No data on bipolar disorder or postpartum depression were available. There is a potential for drug interactions between certain antidepressant medications and hormonal contraceptives.
REPRODUCTIVE TRACT INFECTIONS AND DISORDERS				
VAGINAL BLEEDING PATTERNS		I	C	Clarification: Unusually heavy bleeding should raise the suspicion of a serious underlying condition. Evidence: Evidence from studies examining the treatment effects of the LNG-IUD among women with heavy or prolonged bleeding reported no increase in adverse effects and found the LNG-IUD to be beneficial in the treatment of menorrhagia (74–81).
a) Irregular pattern without heavy bleeding	1	1	1	
b) Heavy or prolonged bleeding (includes regular and irregular patterns)	2	1	2	

INTRAUTERINE DEVICES (IUDs)					
IUDs do not protect against sexually transmitted infections (STIs), including HIV. If there is a risk of STI/HIV, the correct and consistent use of condoms is recommended. When used correctly and consistently, condoms offer one of the most effective methods of protection against STIs, including HIV. Female condoms are effective and safe, but are not used as widely by national programmes as male condoms.					
CONDITION	CATEGORY				CLARIFICATIONS/EVIDENCE
	I = initiation, C = continuation				
	Cu-IUD		LNG-IUD		
† recommendations reviewed for the MEC 5th edition, further details after this table * additional comments after this table	Cu-IUD = copper-bearing IUD LNG-IUD = levonorgestrel-releasing IUD (20 µg/24 hours)				
UNEXPLAINED VAGINAL BLEEDING (suspicious for serious condition)	I	C	I	C	Clarification: If pregnancy or an underlying pathological condition (such as pelvic malignancy) is suspected, it must be evaluated and the category adjusted after evaluation. There is no need to remove the IUD before evaluation.
Before evaluation	4	2	4	2	
ENDOMETRIOSIS	2		1		Evidence: LNG-IUD use among women with endometriosis decreased dysmenorrhoea, pelvic pain and dyspareunia (82–86).
BENIGN OVARIAN TUMOURS (including cysts)	1		1		
SEVERE DYSMENORRHOEA*	2		1		
GESTATIONAL C TROPHOBLASTIC DISEASE					Evidence: Limited evidence suggests that women using an IUD following uterine evacuation for a molar pregnancy are not at increased risk of developing post-molar trophoblastic disease when compared to women using other methods of contraception (87–90).
a) Decreasing or undetectable β-hCG levels	3		3		
b) Persistently elevated β-hCG levels or malignant disease	4		4		
CERVICAL ECTROPION	1		1		
CERVICAL INTRAEPITHELIAL NEOPLASIA (CIN)*	1		2		
CERVICAL CANCER* (awaiting treatment)	I	C	I	C	
	4	2	4	2	
BREAST DISEASE*					
a) Undiagnosed mass	1		2		
b) Benign breast disease	1		1		
c) Family history of cancer	1		1		
d) Breast cancer					
i) current	1		4		
ii) past and no evidence of current disease for 5 years	1		3		
ENDOMETRIAL CANCER*	I	C	I	C	
	4	2	4	2	

INTRAUTERINE DEVICES (IUDs)					
IUDs do not protect against sexually transmitted infections (STIs), including HIV. If there is a risk of STI/HIV, the correct and consistent use of condoms is recommended. When used correctly and consistently, condoms offer one of the most effective methods of protection against STIs, including HIV. Female condoms are effective and safe, but are not used as widely by national programmes as male condoms.					
CONDITION	CATEGORY I = initiation, C = continuation				CLARIFICATIONS/EVIDENCE
	Cu-IUD		LNG-IUD		
† recommendations reviewed for the MEC 5th edition, further details after this table * additional comments after this table	Cu-IUD = copper-bearing IUD LNG-IUD = levonorgestrel-releasing IUD (20 µg/24 hours)				
	I	C	I	C	
OVARIAN CANCER*	3	2	3	2	
UTERINE FIBROIDS*					Evidence: Among women with fibroids, there were no adverse health events with LNG-IUD use, and there was a decrease in symptoms and size of fibroids for some women (91–97).
a) Without distortion of the uterine cavity	1		1		
b) With distortion of the uterine cavity	4		4		
ANATOMICAL ABNORMALITIES*					
a) Distorted uterine cavity (any congenital or acquired uterine abnormality distorting the uterine cavity in a manner that is incompatible with IUD insertion)	4		4		
b) Other abnormalities (including cervical stenosis or cervical lacerations) not distorting the uterine cavity or interfering with IUD insertion	2		2		
PELVIC INFLAMMATORY DISEASE (PID)*					Clarification for continuation: Treat the PID using appropriate antibiotics. There is usually no need for removal of the IUD if the client wishes to continue its use (see WHO publication <i>Selected practice recommendations for contraceptive use</i>) ¹ . Continued use of an IUD depends on the woman's informed choice and her current risk factors for STIs and PID. Evidence: Among IUD users treated for PID, there was no difference in clinical course if the IUD was removed or left in place (98–100).
a) Past PID (assuming no current risk factors for STIs)	I	C	I	C	
i) with subsequent pregnancy	1	1	1	1	
ii) without subsequent pregnancy	2	2	2	2	
b) PID – current	4	2	4	2	

INTRAUTERINE DEVICES (IUDs)					
IUDs do not protect against sexually transmitted infections (STIs), including HIV. If there is a risk of STI/HIV, the correct and consistent use of condoms is recommended. When used correctly and consistently, condoms offer one of the most effective methods of protection against STIs, including HIV. Female condoms are effective and safe, but are not used as widely by national programmes as male condoms.					
CONDITION	CATEGORY				CLARIFICATIONS/EVIDENCE
	I = initiation, C = continuation				
	Cu-IUD		LNG-IUD		
† recommendations reviewed for the MEC 5th edition, further details after this table * additional comments after this table	Cu-IUD = copper-bearing IUD LNG-IUD = levonorgestrel-releasing IUD (20 µg/24 hours)				
STIs†	I	C	I	C	
a) Current purulent cervicitis or chlamydial infection or gonorrhoea	4	2	4	2	<p>Clarification for continuation: Treat the STI using appropriate antibiotics. There is usually no need for removal of the IUD if the client wishes to continue its use. Continued use of an IUD depends on the woman's informed choice and her current risk factors for STIs and PID.</p> <p>Evidence: There is no evidence regarding whether IUD insertion among women with STIs increases the risk of PID compared with no IUD insertion. Among women who have an IUD inserted, the absolute risk of subsequent PID was low among women with STI at the time of insertion but greater than among women with no STI at the time of IUD insertion (101–108).</p>
b) Other STIs (excluding HIV and hepatitis)	2	2	2	2	
c) Vaginitis (including <i>Trichomonas vaginalis</i> and bacterial vaginosis)	2	2	2	2	
d) Increased risk of STIs	2/3	2	2/3	2	<p>Clarification: IUD insertion may further increase the risk of PID among women at increased risk of STIs, although limited evidence suggests that this risk is low. Current algorithms for determining increased risk of STIs have poor predictive value. Risk of STIs varies by individual behaviour and local STI prevalence. Therefore, while many women at increased risk of STIs can generally have an IUD inserted, some women at increased risk (very high individual likelihood) of STIs should generally not have an IUD inserted until appropriate testing and treatment occur.</p> <p>Evidence: Using an algorithm to classify STI risk status among IUD users, 1 study reported that 11% of high-STI-risk women experienced IUD-related complications compared with 5% of those not classified as high risk (104). In another small study, the incidence of PID after IUD insertion was low (2.2%) in a cohort of women considered to be high-risk based on high background rates of STIs in the general population (109).</p>

INTRAUTERINE DEVICES (IUDs)					
IUDs do not protect against sexually transmitted infections (STIs), including HIV. If there is a risk of STI/HIV, the correct and consistent use of condoms is recommended. When used correctly and consistently, condoms offer one of the most effective methods of protection against STIs, including HIV. Female condoms are effective and safe, but are not used as widely by national programmes as male condoms.					
CONDITION	CATEGORY I = initiation, C = continuation				CLARIFICATIONS/EVIDENCE
	Cu-IUD		LNG-IUD		
† recommendations reviewed for the MEC 5th edition, further details after this table * additional comments after this table	Cu-IUD = copper-bearing IUD LNG-IUD = levonorgestrel-releasing IUD (20 µg/24 hours)				
HIV/AIDS†					
HIGH RISK OF HIV	I	C	I	C	Evidence: Among women at risk for HIV, Cu-IUD use did not increase risk of HIV acquisition (110–120).
	2	2	2	2	
ASYMPTOMATIC OR MILD HIV CLINICAL DISEASE (WHO STAGE 1 OR 2)	2	2	2	2	Evidence: Among IUD users, limited evidence shows no increased risk of overall complications or infectious complications when comparing women living with HIV to women not living with HIV. IUD use did not adversely affect progression of HIV when compared to hormonal contraceptive use among women living with HIV. Furthermore, IUD use among women living with HIV was not associated with increased risk of sexual transmission from female to male partners (121–128). One study found no difference in initiation of antiretroviral therapy (ART) or CD4 count between users and non-users of the LNG-IUD (129).
SEVERE OR ADVANCED HIV CLINICAL DISEASE (WHO STAGE 3 OR 4)	3	2	3	2	Clarification for continuation: IUD users with severe or advanced HIV clinical disease should be closely monitored for pelvic infection. Evidence: One study found no difference in ART initiation or CD4 count between users and non-users of the LNG-IUD (129).
OTHER INFECTIONS					
SCHISTOSOMIASIS					
a) Uncomplicated	1		1		
b) Fibrosis of the liver (if severe, see cirrhosis)	1		1		
TUBERCULOSIS*	I	C	I	C	
a) Non-pelvic	1	1	1	1	
a) Pelvic	4	3	4	3	
MALARIA	1		1		

INTRAUTERINE DEVICES (IUDs)			
IUDs do not protect against sexually transmitted infections (STIs), including HIV. If there is a risk of STI/HIV, the correct and consistent use of condoms is recommended. When used correctly and consistently, condoms offer one of the most effective methods of protection against STIs, including HIV. Female condoms are effective and safe, but are not used as widely by national programmes as male condoms.			
CONDITION	CATEGORY		CLARIFICATIONS/EVIDENCE
	I = initiation, C = continuation		
	Cu-IUD	LNG-IUD	
† recommendations reviewed for the MEC 5th edition, further details after this table * additional comments after this table	Cu-IUD = copper-bearing IUD LNG-IUD = levonorgestrel-releasing IUD (20 µg/24 hours)		
ENDOCRINE CONDITIONS			
DIABETES			
a) History of gestational disease	1	1	Evidence: Limited evidence on the use of the LNG-IUD among women with insulin- or non-insulin-dependent diabetes suggests that these methods have little effect on short-term or long-term diabetes control (e.g. HbA1c levels), haemostatic markers or lipid profile (130, 131).
b) Non-vascular disease			
i) non-insulin-dependent	1	2	
ii) insulin-dependent	1	2	
c) Nephropathy/retinopathy/neuropathy	1	2	
d) Other vascular disease or diabetes of > 20 years' duration	1	2	
THYROID DISORDERS			
a) Simple goitre	1	1	
b) Hyperthyroid	1	1	
c) Hypothyroid	1	1	
GASTROINTESTINAL CONDITIONS			
GALL BLADDER DISEASE			
a) Symptomatic			
i) treated by cholecystectomy	1	2	
ii) medically treated	1	2	
iii) current	1	2	
b) Asymptomatic	1	2	
HISTORY OF CHOLESTASIS*			
a) Pregnancy-related	1	1	
b) Past-COC related	1	2	

INTRAUTERINE DEVICES (IUDs)					
IUDs do not protect against sexually transmitted infections (STIs), including HIV. If there is a risk of STI/HIV, the correct and consistent use of condoms is recommended. When used correctly and consistently, condoms offer one of the most effective methods of protection against STIs, including HIV. Female condoms are effective and safe, but are not used as widely by national programmes as male condoms.					
CONDITION	CATEGORY				CLARIFICATIONS/EVIDENCE
	I = initiation, C = continuation				
	Cu-IUD		LNG-IUD		
† recommendations reviewed for the MEC 5th edition, further details after this table * additional comments after this table	Cu-IUD = copper-bearing IUD LNG-IUD = levonorgestrel-releasing IUD (20 µg/24 hours)				
VIRAL HEPATITIS					
a) Acute or flare		1		1	
b) Carrier		1		1	
c) Chronic		1		1	
CIRRHOSIS					
a) Mild (compensated)		1		1	
b) Severe (decompensated)		1		3	
LIVER TUMOURS*					
a) Benign					
i) focal nodular hyperplasia		1		2	
ii) hepatocellular adenoma		1		3	
b) Malignant (hepatoma)		1		3	
ANAEMIAS					
THALASSAEMIA*		2		1	
SICKLE CELL DISEASE*		2		1	
IRON-DEFICIENCY ANAEMIA*		2		1	
DRUG INTERACTIONS					
ANTIRETROVIRAL THERAPY (ART)					Clarification: There is no known interaction between ART and IUD use. However, severe or advanced HIV clinical disease (WHO stage 3 or 4) as a condition is classified as Category 3 for initiation and Category 2 for continuation. Asymptomatic or mild HIV clinical disease (WHO stage 1 or 2) is classified as Category 2 for both initiation and continuation.
a) Nucleoside reverse transcriptase inhibitors (NRTIs)	I	C	I	C	
Abacavir (ABC)	2/3	2	2/3	2	
Tenofovir (TDF)	2/3	2	2/3	2	
Zidovudine (AZT)	2/3	2	2/3	2	
Lamivudine (3TC)	2/3	2	2/3	2	
Didanosine (DDI)	2/3	2	2/3	2	
Emtricitabine (FTC)	2/3	2	2/3	2	
Stavudine (D4T)	2/3	2	2/3	2	

INTRAUTERINE DEVICES (IUDs)					
IUDs do not protect against sexually transmitted infections (STIs), including HIV. If there is a risk of STI/HIV, the correct and consistent use of condoms is recommended. When used correctly and consistently, condoms offer one of the most effective methods of protection against STIs, including HIV. Female condoms are effective and safe, but are not used as widely by national programmes as male condoms					
CONDITION	CATEGORY				CLARIFICATIONS/EVIDENCE
	I = initiation, C = continuation				
	Cu-IUD		LNG-IUD		
† recommendations reviewed for the MEC 5th edition, further details after this table	Cu-IUD = copper-bearing IUD LNG-IUD = levonorgestrel-releasing IUD (20 µg/24 hours)				
* additional comments after this table					
b) Non-nucleoside reverse transcriptase inhibitors (NNRTIs)	I	C	I	C	
Efavirenz (EFV)	2/3	2	2/3	2	
Etravirine (ETR)	2/3	2	2/3	2	
Nevirapine (NVP)	2/3	2	2/3	2	
Rilpivirine (RPV)	2/3	2	2/3	2	
c) Protease inhibitors (PIs)					
Ritonavir-boosted atazanavir (ATV/r)	2/3	2	2/3	2	
Ritonavir-boosted lopinavir (LPV/r)	2/3	2	2/3	2	
Ritonavir-boosted darunavir (DRV/r)	2/3	2	2/3	2	
Ritonavir (RTV)	2/3	2	2/3	2	
d) Integrase inhibitors					
Raltegravir (RAL)	2/3	2	2/3	2	
ANTICONVULSANT THERAPY					
a) Certain anticonvulsants (phenytoin, carbamazepine, barbiturates, primidone, topiramate, oxcarbazepine)	1		1		Evidence: Limited evidence suggests that use of certain anticonvulsants does not interfere with the contraceptive effectiveness of the LNG-IUD (132).
b) Lamotrigine	1		1		Evidence: No drug interactions have been reported among women with epilepsy taking lamotrigine and using the LNG-IUD (133).
ANTIMICROBIAL THERAPY					
a) Broad-spectrum antibiotics	1		1		
b) Antifungals	1		1		
c) Antiparasitics	1		1		
d) Rifampicin or rifabutin therapy	1		1		Evidence: One cross-sectional survey found that rifabutin had no impact on the effectiveness of LNG-IUD (132).

Correcting Misperceptions

Intrauterine devices:

- Are not directly associated with PID.
- Do not increase the risk of contracting STIs, including HIV.
- Do not increase the risk of miscarriage when a woman becomes pregnant after the IUCD is removed.
- Do not make women infertile.
- Do not cause birth defects.
- Do not cause cancer.
- Do not move to the heart or brain.
- Do not cause discomfort or pain for the woman during sex.
- Substantially reduce the risk of ectopic pregnancy.

Screening Questions for Pelvic Examination before IUCD Insertion

For performing the pelvic examination, the questions below help check for signs of conditions that would rule out IUCD insertion. If the answer to all of the questions is "no", then the client can have an IUCD inserted. If the answer to any question is "yes", do not insert an IUCD.

For questions 1 through 5, if the answer is "yes", refer for diagnosis and treatment as appropriate. Help the woman choose another method and counsel her about condom use if she faces any risk of STIs. Give her condoms, if possible. If STI or PID is confirmed and she still wants an IUCD, it may be inserted as soon as she finishes treatment, if she is not at risk for re-infection before insertion.

- Is there any type of ulcer on the vulva, vagina, or cervix?
 - Possible STI.
- Does the client feel pain in her lower abdomen when you move the cervix?
 - Possible PID.
- Is there tenderness in the uterus, ovaries, or fallopian tubes (adnexal tenderness)?
 - Possible PID.
- Is there a purulent cervical discharge?
 - Possible STI or PID.
- Does the cervix bleed easily when touched?
 - Possible STI or cervical cancer.
- Is there an anatomical abnormality of the uterine cavity that will prevent correct IUCD insertion?
 - If an anatomical abnormality distorts the uterine cavity, proper IUCD placement may not be possible. Help the woman choose another method.
- Were you unable to determine the size and/or position of the uterus?
 - Determining the size and position of the uterus before IUCD insertion is essential to ensure high placement of the IUCD and to minimize risk of perforation. If size and position cannot be determined, do not insert an IUCD. Help the woman choose another method.

When to Start

IMPORTANT: In many cases, a woman can start the IUCD at any time it is reasonably certain she is not pregnant.

Having Menstrual Cycles/ Any Time of the Month

If she is starting within 12 days after the start of her monthly bleeding, there is no need for a backup method. If it is more than 12 days after the start of her Monthly cyclic bleeding, she can have the IUCD inserted at any time it is reasonably certain she is not pregnant; there is no need for a backup method.

Switching from another Method

The client can switch from another method immediately, if she has been using the method consistently and correctly or if it is otherwise reasonably certain she is not pregnant. There is no need to wait for her next monthly bleeding and no need for a backup method.

If she is switching from injectables, she can have the IUCD inserted before the next injection is due, there is no need for a backup method.

Soon after Childbirth

She can have an IUCD inserted at any time within 48 hours after giving birth (requires a provider with specific training in postpartum insertion). If it is more than 48 hours after the woman gave birth, delay IUCD insertion until 4 weeks or more after childbirth. (see chapter postpartum family planning)

Fully or Nearly Fully Breastfeeding

Less than 6 months after giving birth if her monthly bleeding has not returned, she can have the IUCD inserted at any time between 4 weeks and 6 months after giving birth. There is no need for a backup method. If her monthly bleeding has returned, she can have the IUCD inserted as advised for women having menstrual cycles.

More than 6 months after giving birth, if her monthly bleeding has not returned, she can have the IUCD inserted at any time it is reasonably certain she is not pregnant. There is no need for a backup method. If her monthly bleeding has returned, she can have the IUCD inserted as advised for women having menstrual cycles (see above).

Partially Breastfeeding or Not Breastfeeding

More than 4 weeks after giving birth, if her monthly bleeding has not returned, she can have the IUCD inserted if it can be determined that she is not pregnant. No need for a backup method. If her monthly bleeding has returned, she can have the IUCD inserted as advised for women having menstrual cycles.

No Monthly Bleeding (not related to childbirth or breastfeeding)

She can have an IUCD inserted at any time if it can be determined that she is not pregnant. No need for a backup method.

After Miscarriage or Abortion

She can have an IUCD inserted immediately, if within 12 days after first- or second-trimester abortion or miscarriage and if no infection is present. There is no need for a backup method.

If it is more than 12 days after first- or second-trimester miscarriage or abortion and no infection is present, she can have the IUCD inserted at any time it is reasonably certain she is not pregnant. There is no need for a backup method.

If infection is present, treat or refer and help the client choose another method. If she still wants the IUCD, it can be inserted after the infection has completely cleared up. IUCD insertion after second-trimester abortion or miscarriage requires specific training. If not specifically trained, delay insertion until at least 4 weeks after miscarriage or abortion.

When to Start Emergency Contraception

Start it within 5 days after unprotected sex. When the time of ovulation can be estimated, the woman can have an IUCD inserted up to 5 days after ovulation. Sometimes this may be 7 days after unprotected sex.

After Taking Emergency Contraceptive Pills (ECPs)

The IUCD can be inserted on the same day that she takes the ECPs; there is no need for a backup method.

Instruments and Equipment Required for IUCD Insertion and Removal

Following is the list of equipment and instruments required for IUCD insertion. All of the instruments must be either sterilized or high-level disinfected before use:

Table 10-1. Instruments and Equipment Required for IUCD Insertion and Removal

Instruments/Equipment	Quantity	Instruments/Equipment	Quantity
Cheatle forceps	1	Container for cheatle forceps	1
Sponge forceps	1	Covered tray for sterilized instruments	1
Tenaculum	1	Covered jar for cotton swabs	1
Bivalve speculum	1	Bowl for antiseptic solution	1
Uterine sound	1	Kidney tray for used instruments	1
Artery forceps	1	Autoclave or boiler for sterilization or high-level disinfection of instruments	1
Scissors, disposable gloves, cotton swabs	1/As required	P/V lamp, torch/emergency light	1
IUCD insertion table	1	Mackintosh	1

Figure 10-1. Instruments and Equipment Required for IUCD Insertion and Removal

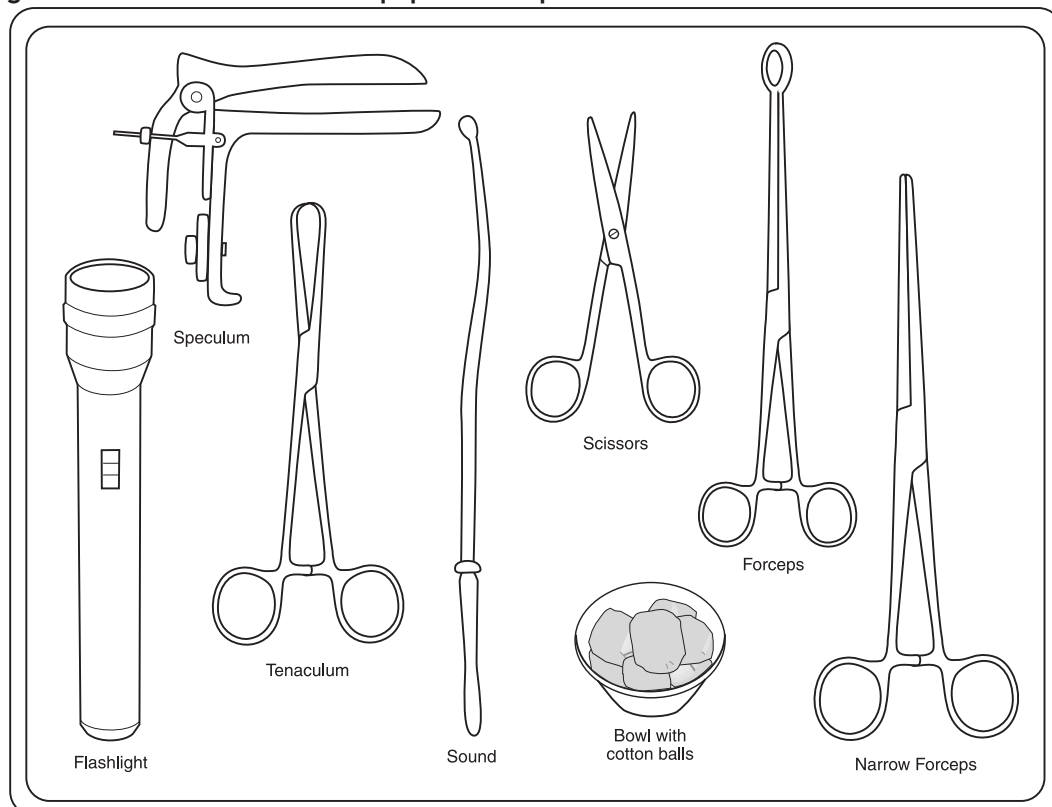

Source: Bluestone J, Chase R, and Lu ER. 2006. IUD Guidelines for Family Planning Service Programs. Jhpiego: Baltimore, Maryland.

IUCD Insertion Technique

A woman who has chosen the IUCD needs to know what will happen during insertion. The following description can help explain the procedure to her. Learning IUCD insertion requires training and practice under direct supervision. Therefore, the steps below are only a summary of the process and should not be considered detailed instructions for insertion:

1. The provider conducts a pelvic examination to assess eligibility (see "Screening Questions for Pelvic Examination before IUCD Insertion" above). The provider first performs the bimanual examination and then inserts a speculum into the vagina to inspect the cervix.
2. The provider cleans the cervix and vagina with appropriate antiseptic.
3. The provider slowly inserts the tenaculum through the speculum and closes the tenaculum just enough to gently hold the cervix and uterus steady.
4. The provider slowly and gently passes the uterine sound through the cervix to measure the depth and position of the uterus.
5. The provider loads the IUCD into the inserter using the no-touch technique.
6. Using the no-touch technique, the provider slowly and gently inserts the IUCD and removes the inserter. The provider cuts the strings of the IUCD, leaving about 3 cm hanging out of the cervix.

7. After the insertion, the woman rests. She remains on the examination table until she feels ready to get dressed.

Postpartum Insertion

Only providers who have special training should insert IUCDs after childbirth. Proper insertion technique is important to reduce the risk of expulsion. An IUCD can be inserted immediately after delivery or up to 48 hours after childbirth.

IUCD Removal Technique

Removing an IUCD is usually simple. It can be done at any time throughout the menstrual cycle. Removal may be somewhat easier during menstruation, when the cervix is dilated. The provider must ensure that proper infection prevention procedures are followed. To remove the IUCD:

- The health care provider pulls the IUCD strings slowly and gently with forceps.
- If removal is not easy, the provider may dilate the cervix using a uterine sound or alligator forceps or refer the client to a specially trained provider.

Side Effects and Management

After IUCD insertion, some clients may have side effects (as mentioned in the section on Post-Procedure Counselling); these are not very serious and usually are resolved within 1–3 months. Most of the time, clients need only reassurance and simple treatment. However, if the symptoms become severe and persistent, the client may need immediate medical attention, and the IUCD may have to be removed.

Table 10-2. IUCDs: Side Effects and Their Management

Side Effect	Management
Changes in menstrual cycle Within 3 months of IUCD insertion	
Irregular bleeding (bleeding at unexpected times that bothers the client)	<ul style="list-style-type: none"> • Reassure her that many women using IUCDs experience irregular bleeding. It is not harmful and usually lessens or stops after the first several months of use. • For modest, short-term relief she can try NSAIDs such as ibuprofen (400 mg) or indomethacin (25 mg) two times daily after meals for 5 days, beginning when irregular bleeding starts. • If irregular bleeding continues, or starts after several months of normal bleeding, or you suspect that something may be wrong for other reasons, consider underlying conditions unrelated to method use (see “Unexplained vaginal bleeding” below).

Side Effect	Management
Heavy or prolonged bleeding	<ul style="list-style-type: none"> • Reassure her that many women using IUCDs experience heavy or prolonged bleeding. It is generally not harmful and usually lessens or stops after the first several months of use. • For modest, short-term relief she can try (one at a time): <ul style="list-style-type: none"> – Tranexamic acid (1,000 mg) three times daily for 3 days, then 1,000 mg once daily for 2 days, beginning when heavy bleeding starts. – Nonsteroidal anti-inflammatory drugs (NSAIDs) such as Mefanamic acid/ ibuprofen (400 mg) or indomethacin (25 mg) two times daily after meals for 5 days, beginning when heavy bleeding starts. Other NSAIDs—except aspirin—also may provide some relief of heavy or prolonged bleeding. • Provide iron tablets if possible and tell her it is important for her to eat foods containing iron. If heavy or prolonged bleeding continues, or starts after several months of normal bleeding or long after the IUCD was inserted, or if you suspect that something may be wrong for other reasons, consider underlying conditions
Cramping and pain	<ul style="list-style-type: none"> • She can expect some cramping and pain for the first day or two after IUCD insertion. • Explain that cramping also is common in the first 3-6 months of IUCD use, particularly during monthly bleeding. Generally, this is not harmful and usually decreases over time. • Suggest Ponston(250-500mg), ibuprofen (200-400 mg), paracetamol (325-1,000 mg), or other pain reliever. If she also has heavy or prolonged bleeding, aspirin should not be used because it may increase bleeding. • If cramping continues and occurs outside of monthly bleeding: <ul style="list-style-type: none"> – Evaluate for underlying health conditions and treat or refer. • If no underlying condition is found and cramping is severe, discuss removing the IUCD: <ul style="list-style-type: none"> – If the removed IUCD looks distorted, or if difficult during removal suggest that the IUCD was out of proper position, explain to the client that she can have a new IUCD that may cause less cramping.

Side Effect	Management
Possible anaemia	<ul style="list-style-type: none"> • The copper-bearing IUCD may contribute to anaemia if a woman already has low iron blood stores before insertion and the IUCD causes heavier monthly bleeding. • Pay special attention to IUCD users with any of the following signs and symptoms: <ul style="list-style-type: none"> – Inside of eyelids or underneath fingernails looks pale, pale skin, fatigue or weakness, dizziness, irritability, headache, ringing in the ears, sore tongue, and brittle nails. – If blood testing is available, haemoglobin less than 11 g/dl or haematocrit less than 30. • Provide iron tablets if possible. • Tell her it is important to eat foods containing iron, such as meat and poultry (especially beef and chicken liver), fish, green leafy vegetables, and legumes (beans, bean curd, lentils, and peas).
Partner can feel IUCD strings during sex	<ul style="list-style-type: none"> • Explain that this happens sometimes when strings are cut too short. • If partner finds the strings bothersome, describe available options: <ul style="list-style-type: none"> – Strings can be cut even shorter so they are not coming out of the cervical canal. Her partner will not feel the strings – the IUCD can be removed and a new one inserted. (To avoid discomfort, the strings should be cut so that 3 cm hang out of the cervix.)

Side Effect	Management
<p>Severe pain in lower abdomen (suspected PID)</p>	<ul style="list-style-type: none"> • Some common signs and symptoms of PID often also occur with other abdominal conditions, such as ectopic pregnancy. If ectopic pregnancy is ruled out, assess for PID. • If possible, do abdominal and pelvic examinations (see signs and symptoms of serious health conditions below). • If a pelvic examination is not possible, and she has a combination of the following signs and symptoms in addition to lower abdominal pain, suspect PID: <ul style="list-style-type: none"> – Unusual vaginal discharge – Fever or chills – Pain during sex or urination – Bleeding after sex or between monthly bleeding – Nausea and vomiting – A tender pelvic mass – Pain when the abdomen is gently pressed (direct abdominal tenderness) or when gently pressed and then suddenly released (rebound abdominal tenderness) • Treat PID or immediately refer for treatment. <p>Because of the serious consequences of PID, health care providers should treat all suspected cases, based on the signs and symptoms:</p> <ul style="list-style-type: none"> • Treatment should be started as soon as possible. Treat for gonorrhoea, chlamydia, and anaerobic bacterial infections. • Counsel the client about condom use and, if possible, give her condoms. • There is no need to remove the IUCD if she wants to continue using it. • If she wants the IUCD removed, take it out after starting antibiotic treatment.

Side Effect	Management
<p>Severe pain in lower abdomen (suspected ectopic pregnancy)</p>	<p>Many conditions can cause severe abdominal pain. Be particularly alert for additional signs or symptoms of ectopic pregnancy, which is rare but can be life-threatening.</p> <p>In the early stages of ectopic pregnancy, symptoms may be absent or mild, but eventually they will become severe. A combination of these signs or symptoms should increase suspicion of ectopic pregnancy:</p> <ul style="list-style-type: none"> • Unusual abdominal pain or tenderness • Abnormal vaginal bleeding or no monthly bleeding, especially if this is a change from the woman's usual bleeding pattern • Light-headedness or dizziness • Fainting <p>If ectopic pregnancy or other serious health condition is suspected, refer at once for immediate diagnosis and care. If the client does not have these additional symptoms or signs, assess for PID.</p>
<p>Suspected uterine perforation</p>	<p>If puncturing is suspected at the time of insertion or sounding of the uterus, stop the procedure immediately (and remove the IUCD if inserted). Observe the client in the clinic carefully:</p> <ul style="list-style-type: none"> • For the first hour, keep the woman at bed rest and check her vital signs (blood pressure, pulse, respiration, and temperature) every 5-10 minutes. • If the woman remains stable after 1 hour, check for signs of intra-abdominal bleeding, such as low haematocrit or haemoglobin, if possible, and her vital signs. Observe for several more hours. If she is stable, she can be sent home, but she should avoid sex for 2 weeks. Help her choose another method. • If she has a rapid pulse and falling blood pressure, or new pain or increasing pain around the uterus, refer her to a higher level of care. <p>If uterine perforation is suspected within 6 weeks after insertion or if it is suspected later and is causing symptoms, refer the client for evaluation to a clinician experienced at removing such IUCDs.</p>
<p>IUCD partially comes out (partial expulsion)</p>	<p>If the IUCD partially comes out, remove the IUCD. Discuss with the client whether she wants another IUCD or a different method. If she wants another IUCD, she can have one inserted at any time it is reasonably certain she is not pregnant. If the client does not want to continue using an IUCD, help her choose another method.</p>

Side Effect	Management
IUCD completely comes out (complete expulsion)	If the client reports that the IUCD came out, discuss with her whether she wants another IUCD or a different method. If she wants another IUCD, she can have one inserted at any time it is reasonably certain she is not pregnant. If complete expulsion is suspected and the client does not know whether the IUCD came out, refer for x-ray or ultrasound to assess whether the IUCD might have moved to the abdominal cavity. Give her a backup method to use in the meantime.
Missing strings (suggesting possible pregnancy, uterine perforation, or expulsion)	<ul style="list-style-type: none"> • Ask the client: <ul style="list-style-type: none"> – Whether and when she saw the IUCD come out – When she last felt the strings – When she had her last monthly bleeding – If she has any symptoms of pregnancy – Has she used a backup method, if IUCD came out. • Always start with minor and safe procedures and be gentle. Check for the strings in the folds of the cervical canal with forceps. About half of missing IUCD strings can be found in the cervical canal. • If strings cannot be located in the cervical canal, either they have gone up into the uterus or the IUCD has been expelled unnoticed. Rule out pregnancy before attempting more invasive procedures. Refer for evaluation. Give her a backup method to use in the meantime, in case the IUCD came out.
New problems that may require switching methods May or may not be due to the method	
Unexplained vaginal bleeding (that suggests a medical condition not related to the IUCD method)	<ul style="list-style-type: none"> • Refer or evaluate by history or pelvic examination. Diagnose and treat as appropriate. • She can continue using the IUCD while her condition is being evaluated. • If bleeding is caused by STI or PID, she can continue using the IUCD during treatment.

Side Effect	Management
Suspected pregnancy	<ul style="list-style-type: none"> • Assess for pregnancy, including ectopic pregnancy. • Explain that an IUCD in the uterus during pregnancy increases the risk of preterm delivery or miscarriage, including infected (septic) miscarriage during the first or second trimester, which can be life-threatening. • If she continues the pregnancy: <ul style="list-style-type: none"> – Advise her that it is best to remove the IUCD. – Explain the risks of pregnancy with an IUCD in place. • Early removal of the IUCD reduces these risks, although the removal procedure itself involves a small risk of miscarriage. • If she agrees to removal, gently remove the IUCD or refer for removal. • Explain that she should return at once if she develops any signs of miscarriage or septic miscarriage (vaginal bleeding, cramping, pain, abnormal vaginal discharge, or fever). • If she chooses to keep the IUCD, her pregnancy should be followed closely by a nurse or doctor. She should see a nurse or doctor at once if she develops any signs of septic miscarriage. • If the IUCD strings cannot be found in the cervical canal and the IUCD cannot be safely retrieved, refer for ultrasound, if possible, to determine whether the IUCD is still in the uterus. If it is, or if ultrasound is not available, her pregnancy should be followed closely. She should seek care at once if she develops any signs of septic miscarriage.

Counselling

If the client chooses an IUCD:

1. Screen the client carefully to make sure there is no medical condition that would be a problem.
2. Explain potential side effects and make sure that each is fully understood. Stress that most can be managed and make sure she knows how to contact you if she has problems.

Pre-Insertion Counseling (Examination/Procedure Area):

1. Inform the client about required physical and pelvic examinations.
2. Describe the insertion procedure and what she should expect during the insertion and afterward.

Counselling

If the client chooses an IUCD:

1. Screen the client carefully to make sure there is no medical condition that would be a problem.
2. Explain potential side effects and make sure that each is fully understood. Stress that most can be managed and make sure she knows how to contact you if she has problems.

Pre-Insertion Counseling (Examination/Procedure Area):

1. Inform the client about required physical and pelvic examinations.
2. Describe the insertion procedure and what she should expect during the insertion and afterward.

Post-Insertion Education:

1. Remind the client what type of IUCD she has and for how long it is effective.
2. Provide a client follow-up card and inform the client when to return for the follow-up visit.
3. Remind the client of warning signs: PAINS (Period late or heavy, Abdominal pain, signs of Infection, Not feeling well, String changes or problems).
4. Review common side effects (menstrual changes) or problems and what to do if they occur.
5. Remind the client of the need to use condoms in addition if she is at risk of sexually transmitted infections.
6. Assure the client she can return to the same clinic to receive advice or medical attention and, if desired, to have the IUCD removed.
7. Ask the client to repeat the instructions.
8. Answer the client's questions.
9. Observe the client for at least 15-20 minutes and ask how she feels before sending her home.

Counselling (removal):

1. Greet the client respectfully and with kindness.
2. Establish the purpose of the visit and answer any questions.
3. Ask the client her reason for removal and answer any questions.
4. Ask the client about her reproductive goals (Does she want to continue spacing or limiting births?) and need for protection against genital tract infections and other STIs.
5. Describe the removal procedure and what she should expect during the removal and afterward.
6. Discuss what to do if the client experiences any problems (e.g., prolonged bleeding or abdominal or pelvic pain).
7. Ask the client to repeat instructions.
8. Answer any questions.
9. If the client wants to continue spacing or limiting births using another method, review general and method-specific information about family planning methods in which she is interested.
10. Help client obtain a new contraceptive method or provide a temporary (barrier)

) method until the method of choice can be started.

11. Observe client for at least 15-20 minutes and ask how she feels before sending her home.

Rarely, allergic skin reaction may develop in a woman using the copper IUCD. In such a case, she should go to a doctor, who may advise removal of the IUCD, and will help her choose another contraceptive method.

Follow-Up

Follow-up care and support of the client's decision to use an IUCD is very important to keep her satisfied and reassured, especially during the first 3 months when side effects are more common.

Explain the follow-up schedule:

- The client can come after her first menses, but not later than 3 months, for her first check-up.
- If she has no complaints subsequently, she can come to the clinic whenever any problem arises.

During the first follow-up visit:

- Ask the client if she has any complaints.
- Check for anaemia if she complains of excessive or prolonged bleeding.
- Do a per speculum pelvic examination to check if:
 - IUCD threads are visible.
 - There are any signs of infection.
 - Do a PAP smear or VIA. If she has never or not had a PAP smear since last 3 years. This can be done at the time of insertion if client is not bleeding.

Recordkeeping

The minimum record list below should be maintained for proper follow-up of IUCD clients:

- Daily clinic register to register the client.
- Client record card (CRC) to record relevant information about the client, e.g., age, parity, menstrual history, and findings of physical and pelvic examinations. Keep a follow-up record on the reverse side of the CRC.
- A client card, to be provided to the client after particulars about the contraceptive are given and the follow-up date are recorded.

Hormone-Containing Intrauterine Contraceptive Devices

Levonorgestrel Intrauterine System (Mirena™)

The Levonorgestrel Intrauterine System (LNG-IUS or LNG-IUCD) is a T-shaped polyethylene device. The frame is 32 mm in both the horizontal and the vertical directions. The cylindrical reservoir around the vertical stem contains a mixture of silicone and 52 mg of levonorgestrel, a progestin widely used in implants, oral contraceptives, and vaginal rings. Twenty-five mcg of levonorgestrel are released every day. A monofilament removal thread is attached to a loop at the end of the vertical stem. LNG IUS is a reversible contraceptive and has several non contraceptive benefits too.



They are available in international market with different trade names:

1. Mirena- effective for 5 years
2. Liletta - effective for 3 years
3. Skyla - effective for 3 years
4. Kyleena - effective for 5 years
5. Eloire - effective for 5 years

Mode of Action

Levonorgestrel is responsible for the contraceptive effect of this IUCD. It has the following three mechanisms of action, which enable it to be highly effective for contraception:

- Thins the uterine lining
- Thickens the cervical mucus
- Inhibits sperm mobility

Effectiveness

- It is very effective for 3-5 years.
- It is one of the most effective and long-lasting methods: There is less than 1 pregnancy per 100 women using an LNG-IUCD over the first year (2 per 1,000 women). This means that 998 of every 1,000 women using LNG-IUCDs will not become pregnant.
- A small risk of pregnancy remains beyond the first year of use and continues as long as the woman is using the LNG-IUCD. Over 5 years of LNG-IUCD use, there is less than 1 pregnancy per 100 women (5-8 per 1,000 women). It is approved for up to 5 years of use.
- Return of fertility after the LNG-IUCD is removed: No delay
- Protection against sexually transmitted infections (STIs): None

Advantages and Limitations

With few exceptions, the mechanism of action, indications, precautions, side effects, complications, and time of insertion are the same as for copper IUCDs.

Advantages

LNG IUS has many advantages over copper IUCDs:

- It is highly effective, having a first-year failure rate of 0.1 percent and 5-year cumulative failure rate of 0.7 percent.
- There is a marked reduction in menstrual blood loss and the systemic level of hormone is very low compared to the other progesterone-only methods.
- Once inserted, it is effective for 5 years and fertility returns rapidly on discontinuation. Eighty percent of the women intending to get pregnant will become pregnant within 12 months of discontinuing Mirena.
- It has many non-contraceptive benefits. It has a beneficial effect on menorrhagia and dysmenorrhoea and reduces the risk of PID. It also reduces the risk of endometrial cancer by 50 percent.
- Other possible side effects are almost the same as those of Copper T 380 A or Multiload.

Limitations

- Women's access to this type of IUCD may be limited.
- The cost of having the device inserted may deter some women from obtaining it.

Who Can Use It?

Nearly all women can use the LNG-IUCD safely and effectively.

Side Effects and Management

Side Effects

Some users report the following:

- Changes in bleeding patterns, including:
 - Periods become lighter with fewer days of bleeding
 - Infrequent bleeding
 - Irregular bleeding
 - No monthly bleeding
 - Prolonged bleeding
- Acne
- Headaches
- Breast tenderness or pain
- Nausea
- Weight gain
- Dizziness
- Mood changes
- Other possible physical changes:
 - Ovarian cysts

Complications

Rare: Perforation of the wall of the uterus by the LNG-IUCD or an instrument used for insertion, Usually heals without treatment.

Very rare: Miscarriage, preterm birth, or infection in the very rare case that the woman becomes pregnant with the LNG-IUCD in place

Client Assessment as per World Health Organization Medical Eligibility Criteria for Levonorgestrel IUCDs

Ask the client the Medical Eligibility Criteria questions for copper-bearing IUCDs. Also ask the questions below about known medical conditions. If she answers “no” to all of the questions here and for the copper-bearing IUCD, then she can have an LNG-IUCD inserted if she wants. If she answers “yes” to a question, follow the instructions. In some cases she can still have an LNG-IUCD inserted.

1. Did you give birth less than 4 weeks ago?
If no, she can have the LNG-IUCD inserted as soon as after childbirth.
2. Do you now have a blood clot in the deep veins of your legs or lungs?
If she reports current blood clot (except superficial clots), help her choose a method without hormones.
3. Do you have severe cirrhosis of the liver, a liver infection, or liver tumour? (Are her eyes or skin unusually yellow? [signs of jaundice])
If she reports serious active liver disease (jaundice, active hepatitis, severe cirrhosis, liver tumour), do not provide the LNG-IUCD. Help her choose a method without hormones.
4. Do you have or have you ever had breast cancer?
Do not insert the LNG-IUCD. Help her choose a method without hormones.

When to Start

IMPORTANT: A woman can start the LNG-IUCD at any time it is reasonably certain she is not pregnant.

Woman Having Menstrual Cycles or Switching from a Non-Hormonal Method at Any Time of the Month

- If she is starting within 7 days after the start of her monthly bleeding, there is no need for a backup method.
- If it is more than 7 days after the start of her monthly bleeding, she can have the LNG-IUCD inserted at any time it is reasonably certain she is not pregnant. She will need a backup method for the first 7 days after insertion. Backup methods include abstinence, male and female condoms and withdrawal.

Tell her that withdrawal a the least effective contraceptive methods. If possible, give her condoms.

Switching from a Hormonal Method

- She can switch immediately, if she has been using the method consistently and correctly or if it is otherwise reasonably certain she is not pregnant. No need to wait for her next monthly bleeding. No need for a backup method.
- If she is switching from injectables, she can have the LNG-IUCD inserted when the repeat injection would have been given. She will need a backup method for the first 7 days after insertion.

Soon after the Birth

Woman can have LNG -IUD immediately after birth till 48 hrs of child birth. After 48 hrs of delivery delay insertion until at least 4 weeks after giving birth

Fully or Nearly Fully Breastfeeding

- If it is less than 6 months after she gave birth: If her monthly bleeding has not returned, she can have the LNG-IUCD inserted any time between 4 weeks and 6 months. There is no need for a backup method. If her monthly bleeding has returned, she can have the LNG-IUCD inserted as advised for women having menstrual cycles.
- If it is more than 6 months since she gave birth: If her monthly bleeding has not returned, she can have the LNG-IUCD inserted at any time it is reasonably certain she is not pregnant. She will need a backup method for the first 7 days after insertion. If her monthly bleeding has returned, she can have the LNG-IUCD inserted as advised for women having menstrual cycles.

Partially Breastfeeding or Not Breastfeeding

If it is less than 4 weeks since the woman gave birth, delay LNG-IUCD insertion until at least 4 weeks after giving birth. If it is more than 4 weeks after giving birth, and if her monthly bleeding has not returned, she can have the LNG-IUCD inserted at any time if it can be determined that she is not pregnant. She will need a backup method for the first 7 days after insertion. If her monthly bleeding has returned, she can have the LNG-IUCD inserted as advised for women having menstrual cycles.

No Monthly Bleeding (not related to childbirth or breastfeeding)

It can be inserted at any time ***if it can be determined that she is not pregnant.***

She will need a backup method for the first 7 days after insertion.

After Miscarriage or Abortion

- It can be inserted immediately, if within 7 days after first- or second-trimester abortion or miscarriage and if no infection is present. There is no need for a backup method. If it is more than 7 days after first- or second-trimester miscarriage or abortion and no infection is present, she can have the LNG-IUCD inserted at any time it is reasonably certain she is not pregnant. She will need a backup method for the first 7 days after insertion.

- If infection is present, treat or refer and help the client choose another method. If she still wants the LNG-IUCD, it can be inserted after the infection has completely cleared up. LNG-IUCD insertion after second-trimester abortion or miscarriage requires specific training. If a specifically trained provider is not available, delay insertion until at least 4 weeks after miscarriage or abortion.

After Taking Emergency Contraceptive Pills (ECPs)

The LNG-IUCD can be inserted within 7 days after the start of her next monthly bleeding or at any other time it is reasonably certain she is not pregnant. Give her a backup method, or oral contraceptives to start the day after she finishes taking the ECPs, to use until the LNG-IUCD is inserted.

Giving Advice on Side Effects

Thorough counselling about bleeding changes must come before IUCD insertion. Counselling about bleeding changes may be the most important help a woman needs to keep using the method.

Describe the Most Common Side Effects

- Changes in bleeding patterns: No monthly bleeding, lighter cyclic bleeding, fewer days of bleeding, infrequent or irregular bleeding.
- Acne, headaches, breast tenderness, and pain, and possibly other side effects.

Explain about These Side Effects

- Bleeding changes usually are not signs of illness.
- They usually lessen after the first several months after insertion.
- The client can come back for help if side effects bother her.



IMPLANTS

Introduction

Hormonal implants are inserted under the skin of the woman's upper arm by a minor surgical procedure. They become effective within a short time (24 hours approximately) after insertion and protect the woman from pregnancy for a period of 3–5 years, depending upon their type. At the end of this period, the contraceptive effectiveness markedly decreases, and a pregnancy may occur in the absence of another contraceptive. The implants should, therefore, be removed, which again requires a minor surgical procedure.

Types of Implants

Contraceptive implants are small, flexible rods placed just under the skin of the upper arm. This package covers a number of contraceptive implant products, specifically Jadelle, Sino-implant (II), Implanon, and Implanon NXT.

The products can be classified as such:

One-rod: Implanon

Implanon NXT (sometimes referred to as Nexplanon)

Two-rod: Jadelle

Sino-implant (II)* (sometimes referred to as Zarin, Femplant, Trust, Simplant)

*Sino-implant (II) is registered in more than 20 countries; it is currently undergoing the WHO prequalification process.

As of March 2014, only Jadelle, Implanon, and Implanon NXT have received WHO pre-qualification, a distinction that guides international procurement agencies and countries for bulk purchasing. Please see Table 1.1 below for information regarding their respective registration statuses.

Table 1.1: WHO Prequalified Products: Manufacturers and Registration Status, March 2014

Product	Manufacturer	Registration
Jadelle	Bayer HealthCare	Registered in more than 50 countries.
Implanon	Merck/MSD	Registered in 73 countries.
Implanon NXT	Merck/MSD	Registered in 55 countries, with numerous additional registrations pending. Will progressively replace Implanon in all countries in the next few years.

This table was modified and updated from a document published by the Reproductive Health Supplies Coalition, accessible at: http://www.path.org/publications/files/RHSC_implants_br.pdf.

Policy

- Implants will be given to women who need a long-term method.
- Insertion will be carried out only by specially trained and certified skilled birth attendant including doctors, lady health visitors and Community midwives from Dept of Health and doctors and Family Welfare Workers from Dept of population welfare.
- Removal will be done preferably by the certified doctors. LHVs and FWWs can only do removal if trained and certified by the population welfare and health departments.
- Implants will not be given to a woman who is pregnant or suspected to be pregnant.
- Implants can be inserted in breastfeeding or no breastfeeding women who are less than 6 weeks postpartum.
- Implants may be inserted immediately after complete abortion.
- Training and regular need based refreshers should be mandatory for providers.
- A log of training and refresher training should also be maintained.

Standards

The following standards should be observed:

- All concerned health care providers should be trained in counselling techniques so that the client is able to make an informed choice.
- Implants should be given only to those women who want long-term protection from pregnancy.
- Implants should be removed after their effective period is over, i.e., 3-5 years after insertion.

Mode of action

- Prevent ovulation.
- Thicken the cervical mucus, making it difficult for sperm to pass through.
- Suppress the endometrium, making it unsuitable for implantation of a fertilized ovum.

Effectiveness

Implants are very effective, i.e., .05 pregnancy occurs per 100 women in first year of use (1 in every 2,000). Over 5 years, 1.6 pregnancies occur per 100 women (1 in every 62). Pregnancy rates have been slightly higher among women weighing more than 70 kilograms (about 150 lbs).

Contraceptive implants are highly effective and provide long-term pregnancy protection: for the two-rod implants, Jadelle provides 5 years of protection and Sino-implant (II) provides 4 years; the one-rod implants provide 3 years of protection.

Implants can be removed by a trained provider at any time, with no delay in the return to fertility.

Neither two-rod nor one-rod implants contains estrogen, and both types are therefore a viable option for breastfeeding women or others who cannot use methods that contain estrogen.

They are more than 99% effective, and provide a significant advantage to women in that little to no action is required of the woman once the implant is inserted.

Compared to other methods of hormonal contraception, contraceptive implants provide a different way to deliver the hormones (levonorgestrel [LNG] in two-rod, etonogestrel [ETG] in one-rod) into the body: the hormones pass continuously into the bloodstream through the walls of the implants at a relatively constant rate. With two-rod implants, the LNG is maintained at an effective level for 4-5 years, regardless of the brand. Thus, a single insertion of this method replaces around 1,800 days of pill taking. With one-rod implants, ETG is maintained at an effective level for 3 years. After contraceptive implants are removed, the hormones' levels drop quickly and normal fertility returns promptly. It's important to note that neither LNG nor ETG are new to hormonal contraception. Both have been used widely in birth control pills, with LNG's origins reaching back over 50 years.

Jadelle levonorgestrel implants are manufactured by Bayer Schering Pharma AG under license from the Population Council, an international contraceptive research organization. Sino-implant (II) is manufactured by Shanghai Dahua Pharmaceuticals. Both Implanon and Implanon NXT are manufactured by Merck & Co, Inc.

Advantages

- Very effective, even in overweight women.
- Long-term pregnancy protection, but reversible. A single decision can lead to very effective contraception for up to 3-7 years.
- No need to do anything at the time of sexual intercourse.
- Increased sexual enjoyment because no need to worry about pregnancy.
- One-time activity.
- Effective within 24 hours after insertion.
- Fertility returns almost immediately after implants are removed.
- They do not affect the quantity and quality of breast milk.
- No oestrogen side effects.
- Help prevent iron deficiency anaemia.
- Help prevent ectopic pregnancies.
- May help prevent endometrial cancer.
- May make sickle cell crises less frequent and less painful.
- May reduce the risk of PID.

Limitations

- The client cannot start or stop use on her own. Capsules must be inserted and removed by a specially trained health care provider.

- Minor surgical procedures are required to insert and remove capsules. Some women may not want anything inserted in their arms or may be bothered that implants may be seen or felt under the skin.
- Discomfort for several hours to 1 day after insertion for some women. Removal is sometimes painful and often more difficult than insertion.
- In very rare instances when pregnancy occurs, as many as one in every six pregnancies is ectopic.
- Do not protect against sexually transmitted infection (STIs), including HIV/ Clinical or non clinical disease.

As per World Health Organization medical Eligibility Criteria for Implants:

Ask the client the questions given below. If she answers "no" to all of the questions, then she can use implants if she wants. If the client answers "yes" to a question below, follow the instructions.

1. Is the client breastfeeding a baby less than 6 weeks old?
Women can start using implants beginning as soon after childbirth MEC 2.
However If a client is fully or almost fully breastfeeding, she is protected from pregnancy for 6 months after childbirth or until her menstrual period returns, whichever comes first. the client must begin contraception at once to avoid pregnancy. Encourage her to continue breastfeeding.
2. Does the client have serious problems with her blood vessels? If so, what problems?
Do not provide implants if she reports blood clots (except superficial clots). Help the client choose another effective method.
3. Does the client have jaundice, cirrhosis of the liver, a liver infection, or tumour?
Perform a physical examination or refer. If the client has serious active liver disease (jaundice, painful or enlarged liver, viral hepatitis, liver tumour), do not insert implants. Refer for care. Help her choose a method without hormones.
4. Does the client have or has she ever had breast cancer?
Do not provide implants. Help the client choose a method without hormones.
5. Does the client have vaginal bleeding that is unusual for her?
If the client is suffering from unexplained vaginal bleeding that suggests pregnancy or an underlying medical condition, do not provide implants. assess and treat any underlying condition, as appropriate, or refer. Help the client choose a method without hormones to use until the problem is assessed. then the client can start using implants.
6. Is the client taking medicine for seizures? Is she taking rifampicin or griseofulvin?
If the client is taking phenytoin, carbamazepine, barbiturates, or primidone for seizures, or rifampicin or griseofulvin, provide condoms to use along with implants if she is on short-term treatment. If the client is on long-term treatment, help the client choose another effective method.
7. Does the client think she is pregnant?
ask if the client is pregnant. If she is in doubt, give her condoms to use until reasonably sure that she is not pregnant. then she can start implants.
Be sure to explain the health benefits, risks, and side effects of the method that the client will use. also, point out any conditions that would make the method inadvisable when relevant to the client.

Indications

Nearly all women can use implants safely and effectively, including women who:

- Breastfeed
- Smoke cigarettes
- Are of any age
- As soon as after childbirth
- Are overweight or underweight
- Just had abortion or miscarriage
- Have benign breast disease
- Have controlled hypertension
- Have iron deficiency anaemia
- Have varicose veins
- Have valvular heart disease
- Have controlled diabetes
- Have thyroid disease
- Have irregular or painful menstrual periods
- Have pelvic inflammatory disease (PID)
- Have benign ovarian tumours or uterine fibroids
- Have endometriosis
- Have STIs
- Have tuberculosis (unless taking rifampicin)

WHO CAN USE CONTRACEPTIVE IMPLANTS?	
<p>Contraceptive implants are appropriate for women who:</p> <ul style="list-style-type: none"> • Want highly effective, reversible contraception that does not require daily action • Are delaying the start of their family, have completed their family, or want children in a year or two • Can tolerate menstrual changes 	<p>Contraceptive implants are NOT appropriate for women who:</p> <ul style="list-style-type: none"> • Are considering having children within the next 6 months • May have little tolerance for menstrual bleeding irregularities (counseling will help identify or overcome this concern) • Express serious concern about the insertion or removal procedure (again, counseling will help overcome this)

BENEFITS AND LIMITATIONS OF CONTRACEPTIVE IMPLANTS

Benefits:

- Highly effective (fewer than 1 pregnancy per 100 women in the first year of use)
- Long-term method
- No daily action required
- Easy to use and require no further action other than follow-up visits and return for removal; do not interfere with normal daily activities
- Comfortable—once the insertion site has fully healed (about 1 week), the rods should not cause any pain and are not noticeable in most women
- One of the lowest doses of any hormonal contraceptive and contains no estrogen
- Few serious side effects

Limitations:

- Changes in menstrual bleeding pattern are common (counseling should prepare the woman adequately for this).
- Insertion and removal are minor surgical procedures and therefore may be associated with bruising (discoloration of the arm), infection, or bleeding.
- A woman cannot discontinue the method on her own (counseling should, however, prepare her for this).
- The outline of the rod(s) may be visible under the skin of some women, especially when the skin is stretched.
- Contraceptive implants do not protect a woman from GTIs and other STIs, including HBV and HIV/AIDS.

When to start

- Any time it is reasonably certain that the client is not pregnant. If she is not at risk of pregnancy (for example, has not had sex since her last menstrual period), she may start using implants at any time she wants.
- If inserted during the first 7 days after menstrual bleeding starts, no backup method is needed for extra protection.
- If she is starting on or after day eight of her menstrual period, she should use condoms or avoid sex for the next 7 days after insertion.
- Immediately, or in the first 7 days after first- or second-trimester miscarriage or abortion.

Switching from a non-hormonal method:

- If it is more than 7 days after the start of her monthly bleeding (more than 5 days for Implanon), she can have implants inserted at any time it is reasonably certain she is not pregnant. She will need a backup method for the first 7 days after insertion.
- If she is switching from an IUCD, she can have implants inserted immediately.

Switching from a hormonal method:

- Immediately, if she has been using the hormonal method consistently and correctly or if it is otherwise reasonably certain she is not pregnant. No need to wait for her next monthly bleeding. No need for a backup method.

- If she is switching from injectables, she can have implants inserted when the repeat injection would have been given. No need for a backup method.
- Effect of Other Medications

The efficacy of implants may be reduced in users who take certain medications that increase the production of the liver enzymes that break down the hormone released from the implants. (These drugs decrease the effectiveness of combined and progestin-only contraceptive pills as well.) The concerns of interaction with implants are minor, but providers should advise use of condoms for dual protection

Some drugs that fall into this category include:

Anti-epilepsy (seizure disorder) drugs such as barbiturates (phenobarbital), phenytoin (Dilantin®), and carbamazepine (Tegretol®), but not valproic acid;

Antibiotics (only rifampin); and

Medications for HIV/AIDS: Certain antiretroviral therapy (ART) medications (most likely protease inhibitors, the non-nucleoside reverse transcriptase inhibitors efavirenz and nevirapine, and cobicistat-boosted elvitegravir) may potentially reduce the effectiveness of combined oral contraceptives and possibly also of contraceptive implants. Women on ART should receive counseling on the potential reduced effectiveness of implants when used simultaneously with certain ART regimens. During counseling, the woman should be offered alternative methods for consideration. However, when the woman decides to initiate or continue with implants, it is recommended that she be counseled on the consistent use of condoms to compensate for any possible reduction in the effectiveness of the implants.

In the WHO's MEC, clients on these medications who desire an implant are "category 2," indicating they generally can use the family planning (FP) method (WHO 2015)

Checklist for Screening Clients Who Want to Initiate Contraceptive Implants

To determine if the client is medically eligible to use implants, ask questions 1–5. As soon as the client answers **YES** to *any question*, stop, and follow the instructions after question 5.

NO	1. Have you ever been told you have breast cancer?	YES
NO	2. Do you currently have a blood clot in your legs or lungs?	YES
NO	3. Do you have a serious liver disease or jaundice (yellow skin or eyes)?	YES
NO	4. Have you ever been told that you have a rheumatic disease, such as lupus?	YES
NO	5. Do you have bleeding between menstrual periods, which is unusual for you, or bleeding after intercourse (sex)?	YES

If the client answered **NO** to *all of questions 1–5*, she can use implants. Proceed to questions 6–11.

If the client answered **YES** to *question 1*, she is not a good candidate for implants. Counsel about other available methods or refer.

If the client answered **YES** to *any of questions 2–5*, implants cannot be initiated without further evaluation. Evaluate or refer as appropriate, and give condoms to use in the meantime. See explanations for more instructions.

Ask questions 6–11 to be reasonably sure that the client is not pregnant. As soon as the client answers **YES** to *any question*, stop, and follow the instructions after question 11.

YES	6. Did your last menstrual period start within the past 7 days?	NO
YES	7. Have you abstained from sexual intercourse since your last menstrual period or delivery?	NO
YES	8. Have you been using a reliable contraceptive method consistently and correctly since your last menstrual period or delivery?	NO
YES	9. Have you had a baby in the last 4 weeks?	NO
YES	10. Did you have a baby less than 6 months ago, are you fully or nearly-fully breastfeeding, and have you had no menstrual period since then?	NO
YES	11. Have you had a miscarriage or abortion in the last 7 days?	NO

If the client answered **YES** to *at least one of questions 6–11* and she is free of signs or symptoms of pregnancy, you can be reasonably sure that she is not pregnant. The client can have implants inserted now.

If the client began her last menstrual period *within the past 7 days (5 days for Implanon)*, she can have implants inserted now. No additional contraceptive protection is needed.

If the client began her last menstrual period *more than 7 days ago (5 days for Implanon)*, she can *have implants inserted now*, but instruct her that she must *use condoms or abstain from sex for the next 7 days*. Give her condoms to use for the next 7 days.

If the client answered **NO** to *all of questions 6–11*, pregnancy cannot be ruled out using the checklist.

Rule out pregnancy by other means. Give her condoms to use until pregnancy can be ruled out.

Offer emergency contraception if every unprotected sex act since last menses occurred within the last 5 days.

Equipment and supplies needed for Implant Insertion

1. Local anaesthetic
2. Diluent
3. Disposable syringe
4. Antiseptic
5. Surgical gloves
6. Roll bandage
7. Saniplast
8. Antibiotics
9. Analgesics
10. Implant kit:
 - Surgical knife handle and blade
 - Kidney tray
 - Bowl
 - Mosquito forceps
 - Sponge-holding forceps
 - Drape sheet
11. Autoclave drum

Below figure shows a cross-section of the upper arm and identifies where the nerve-bundle, major muscles, and vein are. The implant is placed correctly in this figure, well away from major blood vessels, muscles, and nerves.

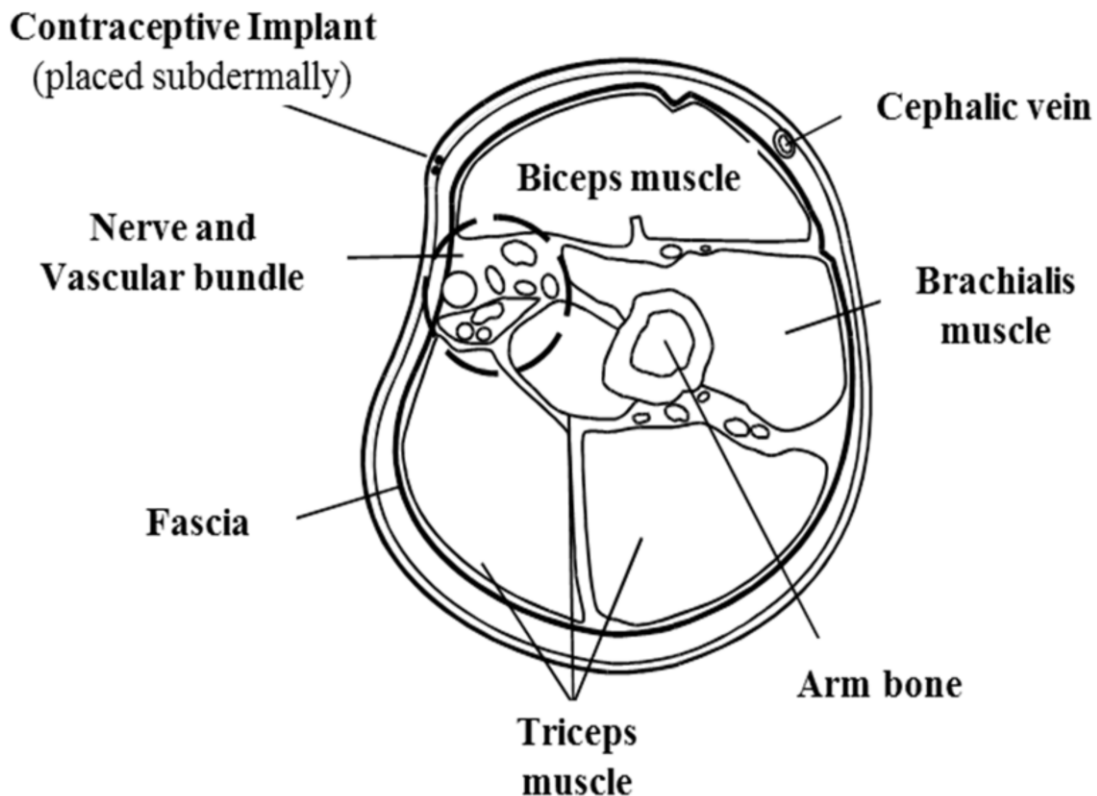

Technique for Insertion of Implanon Rod-1

General Information: One-rod implants consist of a single, rod-shaped implant, containing 68 mg etonogestrel, pre-loaded in the needle of a disposable applicator. Implanon NXT differs only slightly from its predecessor Implanon, in that it is radiopaque, and therefore identifiable

Package: One Implanon package consists of a single implant containing 68 mg etonogestrel that is 4 cm in length and 2 mm in diameter, which is pre-loaded in the needle of a disposable applicator

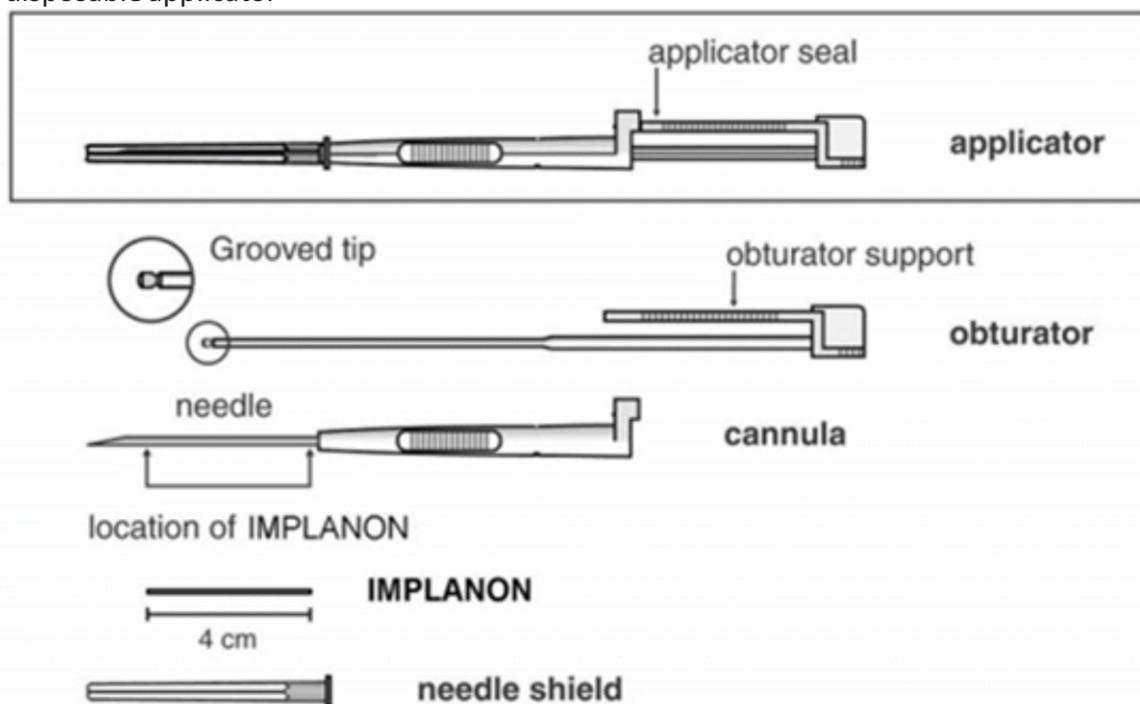

Insertion takes about 10 minutes. Bruising or slight bleeding at the insertion site is normal and common during the first few days after insertion.

- Implanon is inserted at the inner side of the upper arm (the arm that the woman does not write with), with a specially designed applicator.
- The provider (trained doctor) uses proper infection prevention procedures.
- The woman receives an injection of local anaesthetic under the skin of her arm to prevent pain while the implant is being inserted. She stays fully awake throughout the procedure.
- The skin is stretched and the needle is inserted directly under the skin. Once the tip is under the skin, the needle is completely inserted in a movement parallel to the skin.
- After the Implanon is inserted, the provider applies sterile gauze with a pressure bandage to minimize bruising.
- Stitches are not needed. The incision is covered with a dry, sterilized gauze and the arm is wrapped with a bandage.

Technique for Insertion of Two Rod Sinoplant/Jadelle® Implants

General Information:

Jadelle is an implant system that provides effective, long-acting, reversible contraception for women. It contains synthetic progestin. Two thin, flexible rods made of silicone tubing and filled with levonorgestrel are inserted in a woman's upper arm. The cumulative pregnancy rate in clinical trials was 0.3 percent for 3 years and 1.1 percent for 5 years. Jadelle has a lower failure rate than the pill and most IUCDs. Its efficacy is comparable to that of surgical sterilization.

Packaging:

The contraceptive is supplied as a set. One sealed, sterile plastic pouch contains two rods, each filled with 75 mg of levonorgestrel, for use in one woman. A separate package contains the disposable trocar for insertion of the implants.

Procedures:

Jadelle should not be used by women who are pregnant or who have any of these contraindications: active thrombophlebitis or thromboembolic disorders, such as blood clots in the legs, lungs, or eyes; undiagnosed abnormal genital bleeding; acute liver disease; or known or suspected breast cancer. Women who have had previous blood clots or other thromboembolic disorders should consult with their health care providers about whether to use the method.

- Greet the client, rule out pregnancy, determine that the client wants an implant, is aware of common side effects, accepts them, and has no medical condition that makes implants an inappropriate method per WHO MEC.
- Determine the optimal insertion area by measuring 8 cm (3 inches) above the elbow fold. Mark where the incision will be made and the points for the upper end of each rod.
- Prepare an instrument tray and open the sterile instrument pack or high-level disinfected container without touching the instruments and other items.
- Follow the infection prevention practices and fill a syringe with about 2 ml of local anesthetic (1% without epinephrine). This is enough to numb the area while inserting the two rods.
- The rods are inserted under the skin of the inner side of the upper arm in a minor surgical procedure, a local anaesthetic is injected, and the clinician makes a small incision about 3 mm long, using either the disposable inserter or the trocar. The disposable trocar has 2 ring marks and a plunger. The first ring mark that is nearest to the trocar tip is used as a marker for how much of the trocar should be left under the skin following the insertion of each rod. The second ring mark that is closest to the hub indicates how far the trocar should be introduced before loading each rod into the trocar.
- The rods are placed subdermally in the shape of a V opening towards the shoulder. The rods should be inserted by health care providers who have received training in the procedure. Since the incision is small, most women do not have a noticeable scar.

- Palpate the ends of the rods nearest the shoulder to be sure the rods are placed correctly.
- Clean the area around the insertion site with a small amount of sterile or high-level disinfected water or alcohol (“spirits”) applied to a cotton or gauze swab.

SIDE EFFECTS AND MANAGEMENT

Most women using implants have some changes in their menstrual pattern such as spotting or irregular bleeding in between periods. Some may have scanty menses or amenorrhoea after about a year of use. Assure the client that these menstrual changes will not harm her and will settle in a few months. Use the following guidelines to manage problems with

Table 11-1. Hormonal Implants: Side Effects and Their Management

side Effects	Management
Pain in the arm for 1-2 days	<ul style="list-style-type: none"> Reassure client. Give her tab paracetamol.
Pain continues after 2-3 days with swelling of the insertion site	Give her appropriate antibiotic and analgesic and follow her.
Menstrual changes: spotting/slight bleeding between period	<ul style="list-style-type: none"> Reassure the client that it will be resolved on its own. advise ibuprofen up to 800 mg (max) or ponstan 500 mg three times daily after meal for 5 days. Give iron tab 1x3 for 1 month, or Give COC pills 1 daily for 21 days. If this does not help, provide: <ul style="list-style-type: none"> 50 mcg of ethinyl estradiol daily for 21 days. If bleeding continues to be heavy and the client is worried, remove the implants.
Amenorrhoea after scanty menses	Reassure the client that it will not harm her (as it does not harm her when she is pregnant).
Amenorrhoea after regular cycles	<ul style="list-style-type: none"> Do a pregnancy test. If not pregnant, reassure the client. If pregnant, remove the implants.
Rare side effects	
Weight gain	
less than 2 kg in 3 months	<ul style="list-style-type: none"> Reassure the client. ask her to reduce food intake, especially fats and sweets.
more than 2 kg in 3 months	Watch her weight for another 2-3 months on a reduced diet.
If client continues to gain weight	Remove the implants.
Depression or other mood changes	Refer client to a doctor.
Infection at the insertion site (pain, heat, and redness) but no abscess	<ul style="list-style-type: none"> Do not remove the implants. Clean the infected area with soap and water or antiseptic. Give an oral antibiotic for 7 days and ask the client to return in 1 week. If still not better, remove the implants or refer for removal.
Infection with abscess	<ul style="list-style-type: none"> If significant skin infection is involved, give oral antibiotic for 7 days. prepare the infected area with antiseptic, make an incision, and drain the pus. Remove the implants or refer for removal. treat the wound.

Method-specific Counselling

Pre-procedure Counselling

After greeting the client and making her comfortable, ask questions to confirm that she needs a contraceptive for long-term use.

- Show the package containing the implants.
- Give the following information regarding insertion and removal of the implants:
 - The incision for insertion of the capsules is very small.
 - She will not feel any pain because a local anaesthetic will be used.
 - The procedure is performed by a trained provider and takes about 10 minutes.
 - Removal is also done by a trained provider and takes a little more time than insertion.
 - Explain how the implants act as a contraceptive.
 - Tell about their advantages and limitations.
- Listen to her queries and answer them to her satisfaction.
- Dispel doubts or fears that she may have by discussing them and providing relevant information.

Post-procedure Counselling

As detailed below, give all information to the client regarding the follow-up schedule, possible side effects and their management, warning signs, and the importance of getting the implants removed after the effective period is over.

Explain the Follow-Up schedule

- Ask the client to come for a check-up after 1 month and for removal of the implants at the end of their effective lifespan.
- Tell her that she can come at any time she feels there is a problem, or if she has any questions.
- Explain that it is important that she come to the clinic for follow-up.
- Explain that implants can be removed at any time she wants.

Explain Warning signs

Tell the client to come to the clinic as soon as possible if any of the following problems occur:

- D=** Delay in monthly periods
- I=** Infection at insertion site
- S=** Severe abdominal pain
- C=** Capsule of the implant comes out of the skin
- U=** Unusually heavy vaginal bleeding
- S=** Soreness of the arm
- S=** Severe headache or blurred vision

On the first visit, counsel the client along the following lines:

- Repeat the information about implants.
- Consider seriously any complaint or problems faced by the user, and make every attempt to take care of them. Treat minor complaints and refer her to the physician for any major ones.
- Reassure her that removal is available whenever she wants it.
- Ensure that she understands that the implants must be removed after the effective period is over.
- Advise her to return to the same centre for removal after this period, if possible. Otherwise, give her the name and address of another implants centre.
- Check the insertion site to see whether it has healed.
- Check that the implants are in place.

On the visit for removal of implants, do the following:

- Remove the implants.
- Insert a new set of implants if the client desires.

Recordkeeping

Maintain the following minimum record for use in the clinic and for follow-up of the client

- Daily clinic register: to register the client
- Client record card: enter information about age, parity, menstrual history, and findings of physical examination
- Client card: give this to the client after entering the following information
 - Name and location of clinic
 - Name of client and full address
 - Client registration number
 - Date of Implanon/Jadelle insertion
 - Date of expiry/removal due
 - Name of inserting physician
 - Address of the place where Implanon/Jadelle will be removed
 - Warning signs

When to Remove Implants and Counseling

Before removing the rods, talk with the client about her reason for removal and answer any questions. Ask the client about her present reproductive goals (e.g., Does she want to continue spacing or limiting births? Is she hoping to become pregnant again?). If she wants to continue family planning, ask if she wants another contraceptive implant. Briefly describe the removal process and what she can expect both during the removal and afterward.

Preparation for Removal

It is important that the instruments and other items have been sterilized or high-level disinfected.

The following items are needed for removal:

1. Examining table for the woman to lie on (optional)

2. Arm support or side table
3. Soap for washing the arm
4. Ballpoint pen or marker
5. Sterile (or clean), dry surgical drape
6. One bowl for antiseptic solution
7. Pair of sterile surgical gloves
8. Antiseptic solution
9. Local anesthetic (1% concentration without epinephrine)
10. Sterile syringe (5 or 10 ml) and 2.5-4 cm long needle (22-gauge)
11. Scalpel with #11 blade
12. 1 curved mosquito forceps and 1 Crile forceps
13. 1 tissue forceps (optional)
14. Ordinary Band-Aid or sterile gauze with surgical tape
15. Epinephrine for anaphylactic shock (readily available for emergency use)

Equipment for Removal



Removal Technique

An easy removal depends on correct insertion. Routinely, removals take slightly longer than insertions—usually from 5–10 minutes. If the rod(s) are placed correctly—subdermally in the middle third of the upper arm—they will be easier to remove. If they are placed too deep (in the fascia muscle), removal could be difficult and could potentially damage the nerves or blood vessels in the neurovascular compartment.

Technique for Removal of Implants

- Check to be sure the client has washed her entire arm with soap and water and help position the client on the table. Ask her to lie down on the table so that the arm with the rods rests on the table or arm support
- Prepare the instrument tray by carefully opening the Implant Removal Kit. Arrange the instruments. Check that local anesthetic is 1% lignocaine.
- Confirm the position of each rod by making a mark at both ends of the rod(s) using a ballpoint or marking pen and anesthetize the area and follow infection prevention practices
- Push down the proximal end of the implant (Figure 8-5) to stabilize it; a bulge may appear indicating the distal end of the implant. Starting at the distal tip of the implant, make a longitudinal incision of 2 mm long toward the elbow and deep enough to expose the rod.

- Grasp the implant with forceps (preferably curved mosquito forceps) and gently remove the implant
- If the tip of the implant does not become visible in the incision, gently insert a forceps tip into the incision. With a second pair of forceps, carefully dissect the tissue around the implant and grasp the implant
- Confirm that the entire implant has been removed by measuring its length
- If removing two-rod implants, repeat the procedure for the second rod.
- Press down on the incision with a gauzed finger for a minute or so to stop any bleeding. Remove the drape.
- Bring the edges of the incision together and close with a Band-Aid or surgical tape with sterile gauze or cotton
- Follow the infection prevention practices to dispose of the Implant and material.
- Place a note in the client's record indicating the date of removal and specifying any unusual events that may have occurred during removal.
- Provide counselling for continuation of Contraception with the same method or any other option.

Rods That Are Difficult to Remove

Occasionally the rods cannot be removed readily at the first visit. If removal of either rod is difficult (i.e., both rods are not removed within 30 minutes), it may be better to stop the procedure for the client's comfort. In the event that one rod is left in the arm, the client should be provided with a backup contraceptive method. She should be asked to return when the area is fully healed (in about 4–6 weeks) and a second attempt can be made. Usually the remaining rod will be readily located and removed at the second visit.

Remember: The client should be given a backup contraceptive method to use while waiting to have the remaining rod removed if she does not wish to become pregnant.

Rods That Cannot Be Palpated

There are two ways to locate rods that have been inserted too deep to feel with the fingers: x-ray and ultrasound. By using a radiopaque object to mark the original incision site, the rods, which are also radiopaque, usually can be detected by x-ray (set at 50–55 kilovolts and 4–5 milliamperes, exposure time 0.03 seconds). Their depth usually cannot be determined by a single x-ray. Thus, further examination may be required to establish their exact location. With ultrasound, the image caused by the rods also can be detected (i.e., a shadow—echo-free area—will be present under each rod). Special adjustments (positioning of the ultrasound probe) may be necessary to focus the ultrasound image.

Rods That Are Broken

Removal of the rods is more difficult if they are broken during attempts to get them out. Once the rod is damaged, it may break again with each attempt to grasp it with the two-rod-holding or curved forceps. Rarely, removal of a broken rod may require an additional incision at the proximal end of the rod (end nearest the shoulder) so that the remaining piece can be removed more easily. Because two-rod contraceptives are highly elastic and do not immediately return to their original length after being stretched, it may be difficult to determine if all pieces of a broken rod have been removed.

To remove remaining pieces of a broken rod through the original incision:

- Repalpate the arm to locate the missing piece(s),
- Inject more anesthesia if necessary, and
- Grasp the end of the rod with curved (mosquito or Crile) forceps and gently bring it into the incision.

Old Technology

Norplant®-6 Implants

Norplant-6 is a sub-dermal implant consisting of six small capsules containing a progestin hormone, a long-acting and reversible contraceptive method for women. Each capsule is 34 mm long and 2.4 mm wide, and has a silastic tube containing 36 mg of levonorgestrel. The levonorgestrel is released at the rate of approximately 85 mcg per 24 hours during the first few weeks of use, declining over the next 18 months to a constant rate of approximately 30–35 mcg per 24 hours. It is effective for 7 years.

New Technology

Sino-implant (II)

- The Sino-implant (II) is an affordable, subdermal implant made of two thin, flexible rods containing levonorgestrel. Hormonal contraceptive implants aren't new – they were introduced more than 30 years ago – but the Sino-implant (II) is one of the latest iterations designed for "resource-limited settings," according to FHI360, ideal for women in developing countries.
- Although there was no direct evidence regarding Sino-implant (II) among women with medical conditions, studies were identified that looked at safety of the implant among healthy women compared to those who do not use the SI (II). In addition, the safety data from studies of other levonorgestrel (LNG) implants among women with medical conditions is used due to the similarity of SI (II) and other LNG implants in hormone formulation, quality profile and daily release rates. Given this, the panel decided to make the same recommendations for SI (II) as the other LNG implants. Due to heterogeneity of study designs and outcome measures, a meta-analysis was not performed.
- The Sino-implant (II) does not protect against sexually transmitted infections (STIs), including HIV. If there is a risk of STI/HIV, the correct and consistent use of condoms is recommended. When used correctly and consistently, condoms offer one of the most effective methods of protection against STIs, including HIV. Female condoms are effective and safe, but are not used as widely by national programmes as male condoms.
- Voluntary use of contraception by women is critical for upholding their reproductive rights. All women have the right to evidence-based, comprehensive contraceptive information, education and counselling to ensure informed choice. Women's contraceptive choices are made in a particular time, societal and cultural context; choices are complex, multifactorial and subject to change. Decision-making for contraceptive methods usually requires the need to make trade-offs among the different methods, with advantages and disadvantages of specific contraceptive methods varying according to individual circumstances, perceptions and interpretations.

12

VOLUNTARY SURGICAL CONTRACEPTION

Introduction

Voluntary surgical contraception (VSC) is one of the most effective methods of contraception when the desired family size has been achieved. It is also desirable for women or couples for whom another pregnancy might be detrimental to their health.

VSC is one of the most effective forms of contraception and is a one-time procedure intended to be permanent for both men and women. It includes tubal ligation (TL) in the female and vasectomy in the male.

Both TL and vasectomy are usually performed under local anaesthesia. The client is sent home after a few hours, and hospital admission is not required. TL can be performed within one week of delivery or within 48 hours of an abortion or as an interval procedure. Vasectomy is easier, safer, simpler, and less expensive than TL.

Policy

- Surgical contraception will be purely voluntary.
- There will be no element of coercion while offering contraceptive surgery to clients.
- Informed consent of the couple and written consent of both husband and wife will be obtained in every case.
- Clients having two living children are eligible for contraceptive surgery, provided the age of the younger child is more than 1 year.
- VSC should not be denied to any client, regardless of age, who wants to undergo the procedure.
- Contraceptive surgical procedures will be performed only by trained and certified medical doctors.
- staff assisting the surgeon during the surgical procedure must also be trained.
- VSC will be performed by a medical doctor in a properly equipped facility that has acceptable standards of asepsis and infection control.

- Minilaparotomy will be the preferred surgical technique for TL, as compared to laparoscopy.
- No-scalpel vasectomy (NSV) will be the preferred technique for vasectomy.
- To promote vasectomy, more stress should be placed on information, education, and counselling for men.

Standards

The following standards must be maintained:

- Adequate facilities for carrying out the procedure must be available. This includes equipment and drugs to handle life-threatening situations and other emergencies.
- The surgeon and staff must be trained and skilled in the techniques they are using and in the use of appropriate and safe anaesthesia.
- All instruments and equipment must be in optimum working order.
- Strict asepsis must be maintained.
- A back-up or a referral system must be ensured.
- Proper counselling, informed choice, and accurate information regarding the irreversible nature of VSC should be provided to all potential clients.

For Female Sterilization (tubal ligation/minilaparotomy)

- The surgeon must be skilled in the management of emergencies related to the minilaparotomy procedure.
- A backup facility for the management of any complications that may arise must be available.
- Follow-up after 7 days must be ensured for all acceptors.

For Male Sterilization (vasectomy)

- No-scalpel vasectomy (NSV) would be the standard technique for vasectomy. However, where surgeons trained in NSV are not available, the conventional technique would be acceptable.
- All vasectomy clients must be advised to use condoms, or their wives can use a temporary method like pills or injection or abstain from sexual contact, for 3 months after having the vasectomy.
- All vasectomy clients must be advised to get their semen analysis done 3 months after the procedure to make sure that the operation was successful.

Female Sterilization

- Female sterilization provides permanent contraception for women when the desired family size has been achieved.
- It is a safe and simple surgical procedure. It can usually be done with just local anaesthesia and light sedation. Proper infection prevention procedures are required.

- The two most common approaches are minilaparotomy and laparoscopy.

Mode of Action

The doctor makes a small incision in the woman's abdomen and blocks off or cuts the two fallopian tubes. These tubes carry eggs/ovum from the ovaries to the uterus. When the tubes are blocked, the woman's ovum cannot be fertilized by the sperm but she continues to have menstrual periods.

Effectiveness

Female sterilization is very effective and permanent. In the first year after the procedure, 0.5 pregnancies occur per 100 women (1 in every 200 women).

Within 10 years after the procedure, 1.8 pregnancies occur per 100 women (1 in every 55 women). Effectiveness depends partly on how the tubes are blocked, but all pregnancy rates are low.

Advantages

- Very effective.
- Permanent: A single procedure leads to life-long, safe, effective family planning.
- Nothing to remember, no supplies needed, and no repeated clinic visits required.
- No interference with sex; does not affect a woman's ability to have sex.
- Increased sexual enjoyment because no need to worry about pregnancy.
- No effect on breast milk.
- No known long-term side effects or health risks.
- Can be performed just after a woman gives birth.
- May help protect against ovarian cancer.

Limitations

- Requires minor surgery by a specially trained provider.
- Compared with vasectomy, female sterilization is:
 - Slightly more risky
 - Often more expensive
- Reversal surgery is difficult, expensive, and not available in most areas.
- Successful reversal is not guaranteed.
- No protection against sexually transmitted infections (STIs), including HIV/ AIDS.

Client Assessment as per World Health Organization Medical Eligibility Criteria for Female Sterilization

The questions on the following pages check whether the client has any known medical conditions that limit when, where, or how female sterilization should be performed.

The checklist should be used after the client has decided not to have more children, and has chosen female sterilization. It is not meant to replace counselling.

The questions on the checklist refer to known conditions. Generally, the health care provider can learn about these conditions by asking the client. The health care provider does not usually have to perform special laboratory tests to rule out these conditions.

No medical condition prevents a client from having sterilization. Some conditions and circumstances call for delay, referral, or caution, however. These conditions are noted in the checklist.

Delay means delay female sterilization. These conditions must be treated and resolved before female sterilization can be done. Temporary methods should be provided in the meantime.

Refer means refer client to a centre where an experienced surgeon and staff can perform the procedure in a setting equipped with general anaesthesia and other medical support. Temporary methods should be provided.

Caution means the procedure can be performed in a routine setting but with extra preparation and precautions, depending on the condition.

If no conditions require delay or referral, female sterilization can be performed in these routine settings:

Minilaparotomy can be done in RHS-A and RHS-B/ FHC Centres of PWD and OB/GYn unit of health where surgery can be performed. These include both static and mobile camp facilities that can refer clients for special care if needed.

Laparoscopy requires a well-equipped centre, with highly trained staff, one where laparoscopy is performed regularly and an anaesthetist is available.

Client Assessment as per World Health Organization Medical Eligibility Criteria for Female Sterilization

Ask the client the questions below. If the client answers “no” to all of the questions, then the female sterilization procedure can be performed in a routine setting without delay. If the answer is “yes” to a question below, follow the instructions.

1. Does the client have any gynaecological/obstetric conditions or problems (female conditions), such as pregnancy, infection, or cancer? DELAY female sterilization and treat if appropriate or refer in case of:

- Pregnancy
- Postpartum or after second-trimester abortion (7–42 days)
- Serious postpartum or postabortion complications (such as infection or haemorrhage) except uterine rupture or perforation (see below)
- Unexplained vaginal bleeding that suggests a serious condition
- Pre-eclampsia/eclampsia
- Pelvic inflammatory disease (PID) within the past 3 months
- Current STIs
- Pelvic cancers
- Malignant trophoblastic disease

REFER her to a centre with experienced staff and equipment that can handle potential problems:

- Fixed uterus due to previous surgery or infection
- Endometriosis
- Hernia (umbilical or abdominal wall)
- Postpartum uterine rupture or perforation or postabortion uterine perforation

CAUTION:

- Past PID since last pregnancy
- Current breast cancer
- Uterine fibroids
- Previous abdominal or pelvic surgery

2. Does the client have any cardiovascular conditions, such as heart problems, stroke, high blood pressure, or diabetes?

DELAY female sterilization:

- Acute heart disease. Deep vein thrombosis or pulmonary embolism.

REFER to a centre with experienced staff and equipment that can handle potential problems:

- Moderate or severe high blood pressure (160/100 mm Hg or higher)
- Vascular disease
- Complicated valvular heart disease

CAUTION:

- Mild high blood pressure (140/90 mm Hg–159/99 mm Hg)
- History of high blood pressure that can be evaluated and adequately controlled
- Past stroke or heart disease

Client Assessment as per World Health Organization Medical Eligibility Criteria
for Female Sterilization

3. Does the client have any lingering, chronic diseases or any other conditions? Which ones?

DELAY female sterilization in case of:

- Gall bladder disease with symptoms
- Active viral hepatitis
- Severe iron deficiency anaemia (haemoglobin less than 7 g/dl)
- Acute lung disease (bronchitis or pneumonia)
- Systemic infection or significant gastroenteritis
- Abdominal skin infection
- Abdominal surgery due to acute abdomen
- Immobilization due to major surgery
- Post-surgical wound infection
- Current AIDS-related acute illness

REFER her to a centre with experienced staff and equipment that can handle potential problems:

- Severe cirrhosis of the liver
- Diabetes for more than 20 years
- Hyperthyroidism
- Bleeding disorders
- Chronic lung disease
- Pelvic tuberculosis

CAUTION:

- Epilepsy or taking medicine for seizures (phenytoin, carbamazepine, barbiturates, primidone)
- Taking the antibiotics rifampicin or griseofulvin
- Diabetes without vascular disease
- Hypothyroidism
- Mild cirrhosis of the liver, liver tumours, or schistosomiasis with liver fibrosis
- Moderate iron deficiency anaemia (haemoglobin 7–10 g/dl)
- Sickle cell disease
- Inherited anaemia (thalassaemia)
- Kidney disease
- Diaphragmatic hernia
- Severe malnutrition
- Obesity
- Elective abdominal surgery at time sterilization is desired
- Young age
- Mental disorder

Client Assessment as per World Health Organization Medical Eligibility Criteria for Female Sterilization

Be sure to explain the health benefits and risks and side effects of the method that the client will use. Also point out any conditions that would make the method inadvisable.

In general, most clients who want sterilization can have safe and effective procedures in routine settings. With proper counselling and informed consent, sterilization can be used in any circumstances by female clients who:

- Just gave birth (within 7 days)
- Are breastfeeding

Also, clients with the following conditions can have sterilization in a routine setting in any circumstances:

- Past ectopic pregnancy
- Benign ovarian tumours
- Irregular or heavy vaginal bleeding patterns, painful menstruation
- Vaginitis without purulent cervicitis
- Varicose veins
- HIV-positive or high risk of HIV or other STIs
- Uncomplicated schistosomiasis
- Malaria
- Tuberculosis (non-pelvic)

Before the procedure, the client should:

- Not eat or drink anything for 8 hours before surgery, except for clear liquids, which the client can take until 3 hours before surgery.
- Not take any medication for 24 hours before surgery. The morning dose of medicine for hypertensive or diabetes can be taken with doctor's advice.
- Bathe thoroughly, especially belly, genital area, and upper legs.
- Wear clean, loose-fitting clothing.
- Not wear nail polish or jewellery.
- Bring a friend or relative to accompany her home afterwards.

Method of Use

The client can have a female sterilization procedure at any time when the desired family size is achieved:

- If it is certain that she is not pregnant.
- Immediately after childbirth, ideally within 48 hours postpartum but allowable within 7 days after delivery (minilaparotomy procedure only).
- At any time 6 weeks or more after childbirth if it is reasonably certain she is not pregnant.
- At any time after an uncomplicated abortion or miscarriage that is of approximately 12 weeks or less gestational age. In pregnancies that are over 12 weeks of gestational age, the procedure can be safely performed within the first 48 hours after pregnancy termination if there are no associated complications, or after 6 weeks.
 - Any other time, but not between 7 days and 6 weeks postpartum.

Techniques of Female Sterilization

To perform female sterilization, training and practice under direct supervision are required. All health care providers should understand these procedures and be able to discuss them with clients.

The Minilaparotomy Procedure

Below is a description of the interval procedure, used more than 6 weeks after childbirth. The postpartum procedure, used less than 7 days after childbirth, is slightly different.

1. Use proper infection prevention procedures.
2. Ask questions about the client's past and current health, and perform a physical examination and a pelvic examination.
3. Give light sedation to relax the client.
4. Infiltrate local anaesthetic into the incision site just above the pubic hair line.
5. Make a small incision (2-5 cm) in the anaesthetized area and expose the abdominal cavity.
6. Raise and turn the uterus with the uterine elevator to bring each of the two fallopian tubes under the incision.
7. Tie and cut each tube.
8. Close the incision with stitches and cover with adhesive bandages.

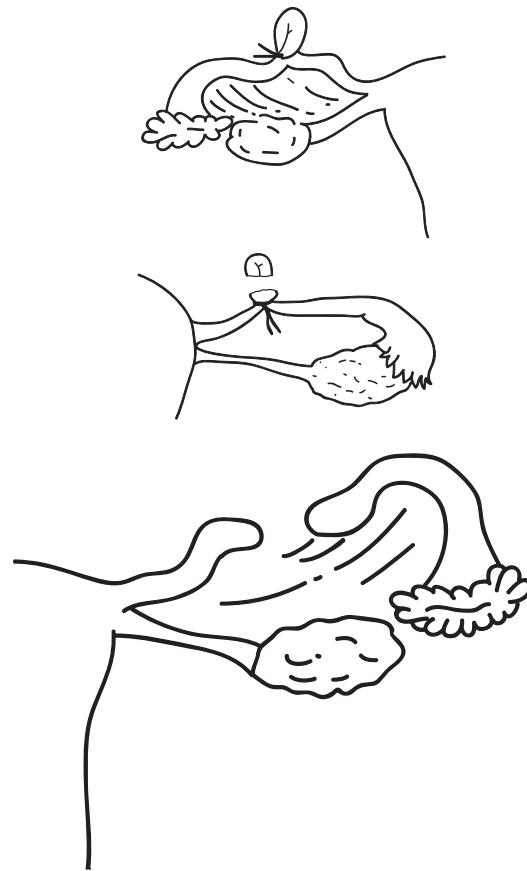

The Laparoscopy Procedure

1. Use proper infection prevention procedures.
2. Ask questions about the client's past and current health, and perform a physical examination and a pelvic examination.
3. Give the client light sedation.
4. Infiltrate the local anaesthetic into the incision site just under the navel.
5. Insert a special needle into the abdomen and, through the needle, introduced gas to inflate the abdomen. This raises the wall of the abdomen away from the organs inside.
6. Make a small incision (about 2 cm) under the navel and insert the trocar.
7. Insert the laparoscope or laprocator through the trocar.
8. Apply the fallope ring or clip using the laprocator to close off the tubes. Each tube is closed with a clip or a ring.

9. After the tubes are closed, remove the trocar and laparoscope. Let the gas come out of the abdomen.
10. Close the incision with stitches and cover it with adhesive bandages.

Anaesthesia

Local anaesthesia, used with or without mild sedation:

- Is safer than general, spinal, or epidural anaesthesia.
- Minimizes the length of the client's stay at the hospital.
- May involve use of many different anaesthetics and sedatives.
- May need to use additional sedation and/or analgesia; this should be adjusted according to the client's body weight.

For situations in which clients need general anaesthesia, see the section on Medical Eligibility Criteria for medical conditions requiring referral to a centre that can provide general anaesthesia.

After the Procedure

The client should:

- Rest for 2 or 3 days and avoid lifting heavy objects for 7 days.
- Keep the incision clean and dry for 2 or 3 days.
- Not rub or irritate the incision for 1 week.
- Take paracetamol or another safe, locally available pain relief medicine, if needed.
- Not have sex for at least 1 week.

Side Effects and Management

- Some discomfort is common after the operative procedure. This discomfort can be relieved with analgesics.
- In laparoscopic ligation, chest and shoulder pain may occur for 1 or 2 days because of trapped gas remaining in the abdominal cavity. This pain can be relieved with analgesics.
- Some women complain of heavy or irregular periods after TL. These are not related to the procedure. If the complaint is troublesome, the client should be referred to a gynaecologist.

Complications of Minilaparotomy

TL using minilaparotomy is a safe procedure, and complications are few. There may, however, be short-term (immediate) or long-term (delayed) complications as listed below.

- Possible short-term (immediate) complications are:
 - Drug reaction
 - Bleeding from the wound
 - Uterine perforation with the uterine elevator
 - Injury to mesosalpinx and broad ligament
 - Bladder or intestinal injury

- Anaesthesia problems
- Tears/transaction of the tubes
- Possible long-term (delayed) complications are:
 - Wound infection
 - Haematoma or abscess formation
 - Menstrual disorders
 - Ectopic pregnancy
 - Failure of sterilization (which is rare)

Complications of Laparoscopic Ligation

- Bleeding
- Visceral injuries
- Infection
- Gas insufflation such as gas embolism, subcutaneous emphysema, and respiratory or cardiac arrest
- Lacerations of large blood vessels or abdominal organs by trocar

Resuscitation and Emergency Management

Anaesthesia Problems

There is a small but definite risk of problems with the use of parenteral sedation and/or analgesia. Emergency drugs should be ready in case a reaction occurs.

Adequate monitoring will lead to early recognition and prompt management of:

- Allergy to the local anaesthetic agent
- Reaction to pre-medication

Haemorrhage during Surgery and Early Post-Operative Period

Haemorrhage may occur with both minilaparotomy and laparoscopic ligation, and may be detected by closely monitoring the vital signs of the client during the pre- and post-operative periods. If haemorrhage occurs, do the following:

- Establish an intravenous line, preferably with a large-bore needle or cannula.
- Introduce intravenous fluids or plasma expanders, if necessary.
- Send blood for grouping and cross-matching and transfuse blood, if necessary, after you receive the laboratory clearance for hepatitis and HIV.
- Take the client into the theatre for emergency surgery. Ensure that a sterile emergency laparotomy kit is available at all times (to meet such emergencies).
- In case of bladder and bowel injury, call a surgeon.

Uterine Perforation

If perforation occurs during minilaparotomy:

- Change the position of the elevator and observe the client.
- If bleeding occurs, apply pressure with a hot-water sponge and use spongostan.
- Apply mattress stitches and, if bleeding does not stop, call a surgeon.

Post-Operative Complications and Management

Infection

TL may be followed by pelvic infection. The chances of infection increase if there is a history of previous sepsis after surgery, or if undiagnosed infection was present before surgery. Immediately refer to the doctor (preferably to the operating surgeon) any client complaining of fever, severe lower abdominal pain, or vaginal discharge. Wound infection may occur, but is usually not serious. The wound should be dressed daily, and if the discharge persists for more than 2 days, refer the client to a doctor.

Menstrual Changes

In some cases, menstrual changes have been reported. Studies have shown that these changes could be due to a decline in the level of serum progesterone.

Other Problems

- Subsequent regret
- Psychological problems

Failure of Tubal Ligation

All tubal occlusion methods have a failure rate, however slight, and the pregnancy that results carries a higher risk of being ectopic.

Pregnancy after TL may occur when:

- The woman may have become pregnant in the same menstrual cycle in which the operation was carried out, i.e., she was already pregnant at the time of surgery.
- Structures other than the tubes were ligated.
- The fallopian ring was not applied properly.
- The cut ends of the tubes reconnected spontaneously.
- The uterine end of the tube developed a fistula with the peritoneal cavity, which may permit the sperms to pass.

If the client complains of amenorrhoea, send her for a pregnancy test. Be alert to the possibility of an ectopic pregnancy if the client complains of amenorrhoea, irregular vaginal bleeding, or lower abdominal pain, and refer her immediately to an appropriate medical facility for diagnosis and treatment.

Post-Operative Danger Signs

- Fever (greater than 100.4oF or 39°C)
- Dizziness with fainting
- Abdominal pain that is persistent or increasing
- Bleeding or fluid oozing from the incision
- Signs of tetanus: Twitching of facial muscles, lockjaw, opisthotonu, etc.

- Abdominal distension associated with vomiting and failure to pass gas Patients with these danger signs should be referred to the doctor immediately.

Counselling

Greet the client, ask her to sit down and make sure that she is comfortable. Now ask her some questions to confirm whether she needs permanent contraception.

Ask the client following questions:

- Do you want to have any more children in the future?
- If not, do you think you could change your mind later? What might change your mind? Suppose, God forbid, one of your children dies?
- Suppose you lose your spouse, and you marry again?
- Have you discussed sterilization with your spouse?
- Does your spouse want more children in the future?
- Do you think your spouse might change his or her mind later?
- Clients who cannot answer these questions may need encouragement to think further about their decisions regarding sterilization.

Special Care

In general, people most likely to regret sterilization have these characteristics:

- Young
- Few or no children
- Have not talked with their spouse about sterilization
- Spouse opposes sterilization
- Not married
- Have problems in their marriage

Also, for a woman, just after delivery or abortion is a convenient and safe time for voluntary sterilization, but women sterilized at this time are more likely to regret it later. Thorough counselling during pregnancy, and ensuring that the woman made her decision well before labour and delivery began, help avoid regrets.

A client should return to the clinic for any of these reasons:

- For a follow-up visit, within 7 days to have stitches removed.
- The client has questions or problems of any kind.
- Return at once if:
 - High fever (greater than 38°C) in the first week
 - Pus or bleeding from the wound
 - Pain, swelling, or redness of the wound
 - Abdominal pain, cramping, or tenderness
 - Fainting or dizziness
- The client suspects pregnancy.
- The client should come to the clinic at once if she has any of the following signs:

- Lower abdominal pain or tenderness on one side
- Abnormal or unusual vaginal bleeding
- Faintness (indicating shock)

Note: Pregnancies among users of voluntary sterilization are rare. But when pregnancy occurs, it is more likely to be ectopic than the normal pregnancy. Ectopic pregnancy is life-threatening. It requires immediate treatment.

Vasectomy

Vasectomy provides permanent contraception for clients who decide that their desired family size has been achieved. It is a safe, simple, quick surgical procedure and can be performed in a clinic. It is not castration, does not affect the testes, and does not affect sexual ability.

Mode of Action

The surgeon makes a small opening in the scrotum and closes off both tubes that carry sperm from the testicles. The semen becomes devoid of sperm and, therefore, pregnancy cannot occur.

Effectiveness

Vasectomy is very effective and permanent when correctly done. Between 2 and 3 pregnancies occur per 100 women in the first year after their husbands have the procedure.

Correctly done means that condoms were used consistently for at least 3 months after the procedure. Semen analysis 3 months after the procedure should be performed to make sure that the vasectomy was successful.

Advantages

- Very effective.
- Permanent: A single, quick procedure leads to life-long, safe and very effective family planning.
- No interference with sex. Does not affect the ability to have sex.
- Increased sexual enjoyment because no need to worry about pregnancy.
- No supplies to obtain and no repeated clinic visits required.
- No apparent long-term health risks.
- Compared with voluntary female sterilization, vasectomy is:
 - A non-invasive procedure
 - Slightly more effective
 - Safer
 - Easier to perform
 - Effectiveness can be checked any time.

- If pregnancy occurs due to failure of vasectomy, it is less likely to be ectopic than a pregnancy in a woman who has been sterilized.

Limitations

- Requires minor surgery by a specially trained provider.
- Not immediately effective. The couple must use another contraceptive method for at least the first 3 months.
- Semen analysis has to be done to make sure that there are no sperm in it and the procedure is successful.
- Reversal surgery is difficult, expensive, and not available in most areas.
- Successful reversal cannot be guaranteed.
- No protection against STIs, including HIV/AIDS.

Client Assessment as per World Health Organization Medical Eligibility Criteria for Female Sterilization

All clients who wish to can have a vasectomy. No medical conditions prevent a client from having vasectomy. This checklist asks the client about known medical conditions that may limit the vasectomy procedure. Ask the client the questions below. If the answer is “no” to all of the questions, then the vasectomy procedure can be performed in a routine setting without delay. If the answer is “yes” to a question given below, follow the instructions, which recommend caution, delay, or special arrangements.

In the checklist below:

Caution means the procedure can be performed in a routine setting but with extra preparation and precautions, depending on the condition.

Delay means postpone vasectomy. These conditions must be treated and resolved before vasectomy can be performed. Give the client another method to use until the procedure can be performed.

Special means special arrangements should be made to perform the procedure in a setting with an experienced surgeon and staff; equipment to provide general anaesthesia is needed as well as other backup medical support. For these conditions, the capacity to decide on the most appropriate procedure and anaesthesia regimen also is needed. Give the client a backup method to use until the procedure can be performed.

1. Does the client have any problems with his genitals, such as infections, swelling, injuries, or lumps on his penis or scrotum?

If client has any of the following, use caution:

- Previous scrotal injury
- Swollen scrotum due to swollen veins or membranes in the spermatic cord or testes (large varicocele or hydrocele)
- Undescended testicle, one side only (Vasectomy is performed only on the normal side. Then, if any sperm are present in a semen sample after 3 months, the other side must be done, too.)

If client has any of the following, delay vasectomy:

- Active STI

Client Assessment as per World Health Organization Medical Eligibility Criteria for Female Sterilization

- Swollen, tender (inflamed) tip of the penis, sperm ducts (epididymis), or testicles
- Scrotal skin infection or a mass in the scrotum

If client has any of the following, make special arrangements:

- Hernia in the groin
- Undescended testicles

2. Does the client have any other conditions or infections? If so, what? If client has the following, use caution:

- Diabetes
- Depression
- Young age

Delay vasectomy if client has:

- Systemic infection or gastroenteritis
 - Filariasis or elephantiasis
- Make special arrangements if:
- Client has AIDS (see vasectomy for men with HIV, below)
 - Client has blood that fails to clot (coagulation disorders)

Vasectomy for Men with HIV

- Clients who are infected with HIV, have AIDS, or are on antiretroviral therapy (ART) can safely have a vasectomy, but special arrangements are needed.
- Vasectomy does not prevent transmission of HIV.
- Advise the client to use condoms correctly and consistently for 3 months post-operatively.
- Coercion or force for getting a vasectomy should be avoided.

Method of Use

Any time client decides that the desired family size is achieved.

Technique of Vasectomy

- Use proper infection prevention procedures at all times.
- Inject local anaesthetic in the scrotum.
- Feel the two vas deferens under the skin in the scrotum.

Make a puncture or incision in the skin:

- Using the no-scalpel vasectomy technique, grasp the vas deferens with specially designed, sharp surgical forceps and make a tiny puncture in the skin at the midline of the scrotum,
OR
- Using the conventional procedure, make one or two small incisions in the skin with a scalpel.
- Lift out a small loop of each vas from the puncture or incision.
- Cut each vas and tie one or both cut ends with thread.
- Cover the puncture with an adhesive bandage.

Side Effects and Management

If a client experiences pain, swelling, or redness at or around the incision, check for clots, pus, infection, or abscess and refer accordingly.

Table 12-1. Vasectomy: Side Effects and Fears, and Their Management

Side Effect	Management
Pain	<ul style="list-style-type: none"> • Check for blood clots in the scrotum: <ul style="list-style-type: none"> – Small, uninfected blood clots require rest and pain relief medication such as paracetamol. – Large blood clots may need to be surgically removed. – Infected blood clots require antibiotics and hospitalization.
Infection (pus, heat, pain, or redness)	<ul style="list-style-type: none"> • Clean site with soap and water or antiseptic. • Give 7- to 10-day course of oral antibiotics.
Abscess (a pocket of pus under the skin)	<ul style="list-style-type: none"> • Clean site with antiseptic. • Incise and drain the abscess. • Perform wound care. • If significant skin infection involved, give 7- to 10-day course of oral antibiotics.
Fear of impotence	Vasectomy does not physically change sexual desire, functioning, or pleasure.

Method-Specific Counselling

Pre-Procedure Counselling

For all clients requesting VSC, follow the steps given below:

- Give them information about temporary methods of contraception.
- Ask the couple what they know about VSC.
- Inform them that VSC is a surgical procedure that it is permanent, and involves cutting and tying of the tubes in the female and of the vas in the male.
- Make sure that the client understands the information correctly and has no misconceptions.
- Explain to the client about the steps of the minilaparotomy or vasectomy procedures.
- Encourage questions.
- Answer questions clearly in terms that the client(s) understands; dispel misconceptions.
- Explain the effectiveness of the procedure, and its failure rate.
- Give written information as well.

- Ensure that the client is not making a decision because of pressure from any person, policy, or incentive to avoid later regrets.

If the client is undecided about accepting VSC:

- Give him/her time to think things over.
- Help him/her choose another method of contraception.
- Ask him/her to come back when he/she has reached a decision.

If VSC is not acceptable:

- Advise a long-term contraceptive such as an IUCD or implant.

When a client is ready to accept VSC:

- Give him/her additional information about the nature of the anaesthesia and surgery, operating theatre routine, post-operative care, side effects, etc., and refer him/her to a VSC facility after you fill out a referral form.
- If TL is the method of choice, give information about the time in relation to menstrual cycle, delivery, and abortion.

If you are counselling a pregnant client, inform her that TL can be performed:

- Within 1 week of delivery, or within 48 hours after abortion (early surgery has the advantage of avoiding re-admission to hospital).
- As an interval procedure at any time after 6 weeks postpartum.

At the VSC centre, the client will be given a consent form to sign in which he/she will again be asked about informed choice, and it will be made clear that he/she is still free to change his/her mind, even though the consent form has been signed.

A separate consent form for males should be available for vasectomy.

Post-Procedure Counselling

After the VSC procedure is over, take the following steps:

- Reassure the client that the procedure will not affect him/her adversely.
- Give instructions, both verbally and in writing, on post-operative care and follow-up.
- Explain how he/she should take the required medication.
- Advise the clients to rest until that evening.
- Tell the client that in case of any problems, he/she should return to the VSC facility. If the procedure is performed in an Extension Service Camp, tell the client to contact the nearest referral centre or hospital, the name of which is entered on the client card.
- Inform the client about warning signs.
- In the case of TL, remind the client to revisit the centre for removal of stitches 1 week after the procedure. (Write down the date on the client card.)
- In the case of TL, if the client is unable to come to the centre, arrange for a trained paramedic to visit the client at home and remove the stitches.
- Advise the client that sexual intercourse can be resumed after 1 week. This applies to female acceptors undergoing interval ligation, as well as to male acceptors, but warn

male acceptors to use condoms for 3 months, and have a semen analysis after 3 months of the procedure to ensure the semen is sperm-free. If the surgeon advises, use scrotal support and avoid cycling for 1 week in case of NSV.

Informed Consent

The client must understand the following points:

- Temporary contraceptives are also available to the client.
- Voluntary sterilization is a surgical procedure.
- There are certain risks involved in the procedure.
- If successful, the operation will prevent the client from having any more children.
- The procedure is considered permanent for all practical reasons.
- The client can decide against the procedure at any time before it takes place.

Follow-Up

After tubal ligation

There should be a follow-up visit within 7 days after the procedure. During the visit, take the following steps:

- Ask the client if there are any complaints. If so, carry out any required examination or, if necessary, refer for an examination and/or treatment.
- Check the operative site for infection.
- Remove the stitches.
- Again, reassure the client, and clear up any doubts or misconceptions.
- If all is well, inform the client that she can resume sexual activity.
- If necessary, plan another follow-up visit. Complete all entries after the follow-up examination.

After NSV

Vasectomy acceptors should also have at least one follow-up examination, preferably after 1 week. During this visit, take the following steps:

- Check the operative site and perform any other relevant examination if indicated.
- Remind the client to use condoms or abstain from sex for 3 months for successful contraception and, after this, have a semen analysis performed to ensure that the semen is sperm-free.

Reversal of Tubal Ligation and Vasectomy

Reversal surgery is difficult, expensive, and not available in most areas of the world. Success cannot be guaranteed. In certain conditions such as death of spouse, death of children due to natural or accidental causes, divorce, or second marriage after divorce, when reversal becomes necessary, refer the client to a properly equipped and well-trained surgical team of a teaching hospital, preferably to a gynaecologist/urologist trained in microsurgery.

Recordkeeping

Maintain the following records:

- The signed consent form.
- Client record card. Complete the information on the client's personal and medical history and investigations.
- After the procedure, notes on the anaesthesia operative procedure, the immediate post-operative period, and treatment.
- The client card with information about follow-up visits and whom to contact in case of problems.
- Printed post-operative care instructions.

Standard Facilities for a Reproductive Health Service Centre

Physical Facilities:

- Running or portable water
- Electricity and other light source
- Toilet facilities
- Reception/registration/counsellor's area
- Examination room
- Space for laboratory tests
- Operating room with screened windows

Room/Area for:

- Auxiliary facilities such as autoclave/sterilization equipment
- Scrub facility/area pre-operative room/area
- Post-operative room

If a room is used for several activities, it is important that clients' privacy be assured.

Staff Requirement

Vasectomy

Staff	No.
Trained doctor	1
Assistant	1
Theatre technician	1
Counsellor/Paramedic	1
Clinic helper	1

Tubal Ligation

Staff	No.
Trained doctor	1
Trained theatre nurse	1
Theatre technician	1
Counsellor	1
Assistant	2
Helper	1
Clerk	1
Driver	1
Sweeper	1

Other Material and Medicine Required for Minilaparotomy

Suture Material and Other Items

- o Black silk or black thread
- o Chromic catgut No. 1
- o Sterile gauze squares (4" x 4")
- o Sterile cotton balls

Linen for One Operation

Item	No.
Drape, towel with eyehole	6
Gowns	4
Masks	4
Caps	4
Pairs of gloves size 6, 6.5, 7 and 7.5 with glove powder	6
Packing towels	2
Soap	1
Surgical nail brush (nylon)	3

Medicines

- Prep solution: Betadine
- Methylated spirit
- Sedatives/tranquilizers:
- Local anaesthetic: Xylocaine 1%
- Adhesive plaster
- Analgesics (12 tablets/patient):
- Tab. Paracetamol or Panadol 1 TDS
- Antibiotics (when required): 20 capsules per client:
- Cap. Tetracycline 250 mg, or
- Cap. Amoxicillin 250 mg 6 hourly x 5 days
- Iron sulphate tablets

Emergency and Resuscitation Equipment

- Oro-pharyngeal airways-2 sizes
- Ambu bag
- Laryngoscope and endotracheal tubes
- Suction machine with tubing and two traps
- Oxygen tank with reducing valve, flow meter, tubing, and mask
- Intravenous administration sets with large-calibre needles
- I.V. fluids, Normal Saline, dextrose-saline/dextrose 5%
- Emergency drugs and antidotes to anaesthetic or other drugs
- Venisection set
- Standard laparotomy set
- Inj Solucortif
- B.P/ PULSE Monitor and Oximeter.

Note: The tray containing drugs and equipment should be kept in an accessible place in good working order and the staff should be familiar with its location and proper use.

Medical History Record Card for Tubal Ligation/Vasectomy

Name and address of the RH Centre: _____ Client Reg. No.:

A. History

Name of the client: _____

Husband's/Father's name: _____

Complete address: _____

Referred by: _____

Age of the client (Years): Age of husband/wife (Years):

Occupation of husband: _____ Occupation of wife: _____

Education of wife: 1. Illiterate 3. Middle
 2. Primary 4. High school or above

Education of husband: 1. Illiterate 3. Middle
 2. Primary 4. High school or above

Duration of marriage (Years):

Total number of children born:

Number of children alive: Boys Girls

Age of the last living child: Months

Total Number of:
Stillbirths Spontaneous abortions Induced abortions

Outcome of the last pregnancy: 1. Live birth
 2. Stillbirth
 3. Abortion

Previous use of contraceptives:

- 0. None
- 1. Oral Pill
- 2. IUCD
- 3. Foam/Jelly/Diaphragm
- 4. Rhythm/Withdrawal
- 5. Condom
- 6. Injectable
- 7. Combination of above methods

Menstrual History: 24 25 26 27 28 29

Date of LMP: / /
 Day Month Year

- 1. Regular
- 2. Irregular

- 1. Scanty
- 2. Normal
- 3. Heavy

Past History:

- 1. Diabetes
- 2. Hypertension
- 3. Peritonitis
- 4. Hernia
- 5. Lung infection
- 6. Jaundice
- 7. Heart disease
- 8. History of drug allergy
- 9. Any abdominal operation
- 10. None

Laboratory Investigation:

- Urine
- 1. Diabetes
 - 2. Albumin positive
 - 3. Sugar positive
 - 4. Sugar + Albumin positive

- Blood Hb%
- 1. Less than 50%
 - 2. 50-60%
 - 3. 60% and above

- Examination
- 1. Normal
 - 2. Not normal

General examination:

Weight: _____ Kgs B.P.: _____ Temp.: _____ C.V.S.

Resp. System: _____ Abdomen: _____

- Pelvic examination (Findings):
- 1. Normal
 - 2. Not normal

- P/S examination (Findings):
- 1. Normal
 - 2. Not normal

Remarks of doctor: _____

B. Pre-Operative Medication

	Drug	Dose	Route
1	_____	_____	_____
2	_____	_____	_____
3	_____	_____	_____
4	_____	_____	_____

C. Operative Procedure and Medication

Date of LMP: / /
Day Month Year

Name of surgeon: _____

Assisted by (name of doctor): _____

Operative procedure: Minilap/Laparoscopy/Other (specify): _____

Type of local anaesthesia: _____

Vital sign monitoring during surgery: _____

B.P.: _____ Pulse: _____ Respiration _____

Duration of surgery: _____

Name and Signature of Doctor

D. Operative Procedure and Medication

Complication of operative procedure (specify): _____

Management of these complications (state briefly): _____

Date of discharge of client: _____

Condition discharge: B.P.: _____ Pulse: _____ Temp. _____

General conditions: _____

Post-operative instructions including medicines given: _____

Name and Signature of Doctor

Date: _____

E. Follow-Up

Date: _____

- 1. Satisfactory
- 2. Not satisfactory

a. General condition of client: _____

13

EMERGENCY CONTRACEPTIVES

Introduction

Emergency contraception (EC) is a method used by a woman to prevent an unwanted pregnancy after unprotected sexual intercourse.

There are currently two methods of EC:

- Oral emergency contraceptive pills (ECPs)
- Copper-bearing intrauterine contraceptive device (IUCD)

Emergency contraceptive pills (ECPs) are sometimes referred to as "morning- after" or "post-coital" pills, but since these terms do not convey the correct timing for EC use, the preferred term is emergency contraceptive pills. ECPs should be used within 120 hours (5 days) after unprotected intercourse.

Types of ECPs that are available are:

- Oral contraceptives containing only progestin (levonorgestrel)
- Combined oral contraceptives (COCs) containing an oestrogen (ethinyl estradiol) and a progestin (levonorgestrel); this is known as the Yuzpe method
- Ulipristal Acetate 30 mg tablet.

A copper-bearing IUCD (Copper T 380A or Multiload Cu-375) can also be used as EC when inserted within 5 days of unprotected intercourse. The IUCD can remain in place to serve as a regular contraceptive for up to 5-12 years, and it can be removed by a trained health provider whenever the client wishes.

Policy

Emergency contraception:

- Will be used by women only in case of emergency.
- Will be dispensed by trained and skilled service providers.
- Will be dispensed with counselling about its side effects.
- Will not be used as a regular method of family planning.

Standards

The following standards should be observed:

- The client seeking EC should be provided with all necessary information regarding advantages, limitations, and side effects of the EC.
- EC should be dispensed and used within 120 hours of the unprotected act.
- Before dispensing it, the provider should ensure that the woman is not pregnant.
- The client should be counselled to start a regular method immediately or avoid sex until the start of the preferred method.

Mode of Action

Levonorgestrel ECPs have been shown to prevent ovulation, and do not have any detectable effect on the endometrium or progesterone levels when given after ovulation.

ECPs are not effective once the process of implantation has begun and will not cause abortion.

Effectiveness

- ECP: Effective when used within 120 hours-after sex
 - If 100 women each had sex once during the second or third week of the menstrual cycle without using contraception, eight would likely become pregnant.
 - If all 100 women used progestin-only ECPs, one would likely become pregnant.
 - If all 100 women used oestrogen and progestin ECPs, two would likely become pregnant.
- Copper-bearing IUCD:
 - The failure rate is not higher than 0.2 percent.
- Return to fertility:
 - A woman can become pregnant immediately after taking ECPs. They prevent pregnancy only from acts of sex that took place up to 5 days before. They will not protect a woman from pregnancy and from the act of sex after she takes ECPs, not even on the next day.

Advantages

- Safe and effective
- Easy to use
- Few or temporary side effects
- Can also be used by breastfeeding women

Emergency Contraceptives

- Not associated with birth defects in case the method fails

- Can have in hand in case an emergency arises
- Do not cause delay in fertility return
- Women with HIV/AIDS and on ART can safely use

Limitations

- Should be taken within 120 hours after unprotected sex.
- Can cause minor side effects.
- Do not provide ongoing protection against pregnancy.
- Do not protect against sexually transmitted infections (STIs) and HIV/AIDS.

Client Assessment as per WHO Medical Eligibility Criteria

All women can use ECPs safely and effectively, including women who cannot use ongoing hormonal contraceptive methods. There are no medical conditions that make ECPs unsafe for any women because of the short-term nature of their use.

Method of Use

Any woman of reproductive age may need EC at some point to avoid an unwanted pregnancy. EC is meant to be used after intercourse in situations such as:

- When no contraceptive has been used and the client does not want to get pregnant.
- When there is a contraceptive failure or incorrect use, including:
 - Condom breakage, slippage, or incorrect use.
 - If the client missed three or more consecutive COC pills.
 - Progestin-only pill (mini-pill) taken more than 3 hours late.
 - Progestin-only contraceptive injection, depot-medroxyprogesterone acetate, or norethindrone enanthate received more than 4 weeks or 2 weeks late respectively.
 - A combined oestrogen-plus-progestin monthly injection received more than 7 days late; or dislodgement, delay in placing, or early removal of a contraceptive hormonal skin patch or vaginal ring.
 - Dislodgement, breakage, tearing, or early removal of a diaphragm or cervical cap.
 - Failed coitus interruptus (e.g. ejaculation in vagina or on external genitalia).
 - Failure of a spermicide tablet or film to melt before intercourse.
 - Miscalculation of the periodic abstinence method or failure to abstain on fertile day of cycle.
 - IUCD expulsion.
- In cases of sexual assault when the woman was not protected by an effective contraceptive method.

While all women in situations of conflict are vulnerable to sexual assault, young female adolescents may be the group most in need of EC services. Adolescent refugees are often targeted for sexual exploitation and rape, yet there are relatively few programmes that address the specific reproductive health needs of young people, and even fewer that provide EC.

As with all health interventions, EC should be implemented in accordance with cultural values and national protocols. EC is one component of reproductive health care, and communities need to receive full and impartial information and counselling about it as they do for all other forms of reproductive health care.

Health workers may require additional training in EC if they are not familiar with its use to ensure a sensitive and culturally appropriate response to women's needs. EC services are aligned with national laws and policies.

Dedicated ECP products are specially packaged with the appropriate higher dosages of the two types. Both ECP types are effective, but the preferred method is the progestin-only contraceptive, due to its higher efficacy rate and lower risk of nausea and vomiting.

Each type of contraceptive has different regimens, with both high and low doses. The charts and descriptions below detail the regimens for each type of ECP. For all regimens, ECPs should be taken as soon as possible after intercourse, but optimally within 120 hours.

Table 13-1. Types of Emergency Contraceptive Pills and Their Doses

Formulation (Examples of Brands)	Number of Pills to Swallow within 120 Hours
Progestin-only oral contraceptives containing 0.075 mg (75 mcg) of norgestrel (<i>Ovrette, Neogest, Norgeal</i>)	40
Progestin-only oral contraceptives containing 0.03 mg (30 mcg) of levonorgestrel (<i>Folistrel, Microval, Microlut, Microluton, Mikro-30 Wyeth, Mikro-30, Norgeston, Nortrel</i>)	50
Low-dose COCs containing 0.15 mg of levonorgestrel plus 0.03 mg (30 mcg) of ethinyl estradiol (<i>Nova, Novadol, Famila</i>)	8 (4 stat and 4 after 12 hours)
Levonorgestrel 0.75 mg (<i>Postinor-2/EC/ECP/ EmKit</i>)	2
Ulipristal Acetate tablet 30 mg	1

- Ulipristal acetate (UPA) was added as a new method to the MEC.
- The duration of use of ECPs is less than the duration of regular use of COCs or POPs and thus would be expected to have less clinical impact for women with history of severe cardiovascular complications, migraine or severe liver disease (including jaundice). There are no restrictions for the use of ECPs in cases of rape.
- Women who are breastfeeding can use COCs or LNG regimens for ECPs without restriction (MEC Category 1). Women who are breastfeeding can generally use UPA (MEC Category)
- Breastfeeding is not recommended for one week after taking UPA since it is excreted in breast-milk. Breast-milk should be expressed and discarded during that time

- Women who are obese can use COCs, LNG or UPA for ECPs without restriction (MEC Category 1). ECPs may be less effective among women with BMI ≥ 30 kg/m² than among women with BMI < 25 kg/m². Despite this, there are no safety concerns.

Recommendations for emergency contraceptive pills (ECPs) - ulipristal acetate (UPA) as a new method added to the guideline and obesity as a new condition for ECP use	
Pregnancy	For pregnant women, ECP use is not applicable.
Breastfeeding	Breastfeeding women can use combined oral contraceptive pills (COCs) or LNG for ECPs without restriction (MEC Category 1). Women who are breastfeeding can generally use UPA for ECPs (MEC Category 2).
Past ectopic pregnancies	Women who have experienced past ectopic pregnancies can use COCs, LNG or UPA for ECPs without restriction (MEC Category 1).
History of severe cardiovascular disease	Women with history of severe cardiovascular disease, including ischaemic heart disease, cerebrovascular attack or other thromboembolic conditions, can generally use COCs, LNG or UPA for ECPs (MEC Category 2).
Migraines	Women with migraines can generally use COCs, LNG or UPA for ECPs (MEC Category 2).
Severe liver disease	Women with severe liver disease, including jaundice (a personal characteristic and sign of liver disease prior to diagnosis), can generally use COCs, LNG or UPA for ECPs (MEC Category 2).
Use of CYP3A4 inducer	Women using CYP3A4 inducers can use COCs, LNG or UPA for ECPs without restriction (MEC Category 1).
Repeat use of ECP	There are no restrictions on repeated use for COCs, LNG or UPA for ECPs (MEC Category 1).
Rape	There are no restrictions for use of COCs, LNG or UPA for ECPs in cases of rape (MEC Category 1).
Obesity	Women who are obese can use COCs, LNG or UPA for ECPs without restriction (MEC Category 1).

Table 13-2. Emergency Contraceptive Pills: Side Effects and Their Management

Side Effect	Management
<p>Nausea: Nausea is the most common side effect of ECPs. About 50 percent of women using COCs and 20 percent of women using progestin-only pills for EC experience nausea. It usually does not last more than 24 hours.</p>	<ul style="list-style-type: none"> • Routine use of antiemetic medications is not recommended. • If previously experienced nausea with ECP dose, take a single dose of meclizine 1 hour before the first dose of ECPs to help reduce the risk of nausea and vomiting. Clients should be warned that medicine may cause drowsiness. Evidence does not suggest that taking ECPs with food will alter the risk of nausea.
<p>Vomiting: Vomiting occurs in 20 percent of women using COCs and 5 percent of women using progestin-only pills. Vomiting within 2 hours of taking ECPs can reduce the effectiveness of the method.</p>	<p>Repeat the dose if vomiting occurs within 2 hours of taking the pills. If vomiting is severe, the repeat dose may be administered high-up vaginally.</p>
<p>Irregular uterine bleeding: Spotting may occur in some women.</p>	<ul style="list-style-type: none"> • It will usually stop without treatment. • Assure the women that it is not a sign of illness.
<p>Changes in the time of next monthly bleeding or suspected pregnancy</p>	<ul style="list-style-type: none"> • If menstruation is delayed by more than a week, a pregnancy test should be performed. • Monthly bleeding will start earlier or later and is not a sign of illness.
<p>Other side effects: Other side effects that have been reported with EC include breast tenderness, headache, dizziness, and fatigue. These side effects usually do not last more than 24 hours.</p>	<p>Pain relievers, like aspirin or paracetamol, can be used to reduce discomfort.</p>

Method-Specific Counselling for Emergency Contraception

Health care providers who counsel clients about EC should be careful to withhold judgemental comments and refrain from expressing disapproval of a client's decision.

Explaining the Use of Emergency Contraception

- Explain emergency oral contraception, its side effects, and effectiveness.
- Provide the pills for emergency oral contraception or insert an IUCD as chosen by the client after counselling.
- If the client is already pregnant, do not provide ECPs.

Follow-Up

1. Advise the client to return or to see the health care provider if her next period is quite different from the usual, especially if it is:
 - Unusually light (possible pregnancy)
 - Does not start within 4 weeks (possible pregnancy)
 - Unusually painful (possible ectopic pregnancy, but emergency oral contraception does not cause ectopic pregnancy)
2. Describe the symptoms of STIs, for example, lower abdominal pain, unusual vaginal discharge, or pain or burning on urination. Advise her to see a health care provider if any of these symptoms occurs.
3. As EC is appropriate for emergency use only, clients should be offered information on other contraceptive methods that they can use on a regular basis. However, it is important to inform clients that while EC should not be used as a regular contraceptive method, its recurrent use will not pose a health risk.
4. Clients who have opted for the IUCD as their preferred EC (when appropriate and possible) should be made aware that this IUCD can serve as their regular family planning method for a maximum of 5–12 years. (The Copper T is approved for up to 12 years; the Multiload is approved for up to 5 years.)

14

ADVANCES IN CONTRACEPTIVE TECHNOLOGY

Introduction

Many new contraceptive methods have been developed in recent years. Some of these have been approved by the U.S. Food and Drug Administration. All of these methods can be grouped under five categories:

- Barrier methods
- Combined hormonal contraceptives
- Intrauterine devices
- Implants
- Male sterilization

Policy

- Provide better options and choices for contraception.
- Introduce new contraceptives after trials under local conditions and obtaining conclusive evidence of efficacy and safety of method.
- Disseminate the information to stakeholders and formally launch the methods after approval by Departments of Health and Population welfare.

Standards

All of the concerned health care providers will be trained in the procedure and in management of side effects before introducing any new contraceptives into the programme.

Services meeting high standards of quality will be made available in the clinics/ centres for providing the new contraceptives and dealing with their side effects.

Barrier Methods

Cervical Barrier (Lea's Shield®)

Features

Lea's Shield was approved by the U.S. Food and Drug Administration in March 2002. It is a reusable cervical barrier made of medical grade silicone rubber. Lea's Shield has the same shape as the cervical cap and it also contains a valve in the centre and a loop at the anterior end to facilitate removal.



Mode of Action

It acts by preventing sperm from entering the cervix.

Effectiveness

The first year failure rate is 9-14 percent. The failure rate varies by parity and concurrent use of spermicides.

Women choosing Lea's Shield as a contraceptive method require a clinician's assistance and instructions during the first use; it is therefore available by prescription only.

For maximum effectiveness, Lea's Shield should be inserted into the vagina anytime before intercourse and should be left in for 8 hours after intercourse.

The shield should never be left in the vagina for more than 48 hours. It should be properly cleaned and stored for future use.

Fitting this device is quite simple. The user needs guidance from a clinician to understand how to use it. The woman inserts Lea's Shield after listening to the clinician's instructions. The clinician then checks to see if the cervix is covered, the loop fits behind the symphysis, and the woman is comfortable. Once the client is comfortable and is able to insert the device correctly, she can continue using it independently.

FEMALE BARRIER METHOD:

1. The FC2 female condom is made from synthetic latex which is softer than polyurethane and is manufactured by a dipping process which is cheaper than the welding used in the original type. The VA feminine condom (also known as the Reddy condom and V-Amour) contains a soft sponge to hold it in place inside the vagina rather than a ring; it has a higher acceptability than the FC1.

2. Caya contoured diaphragm (formerly SILCS)

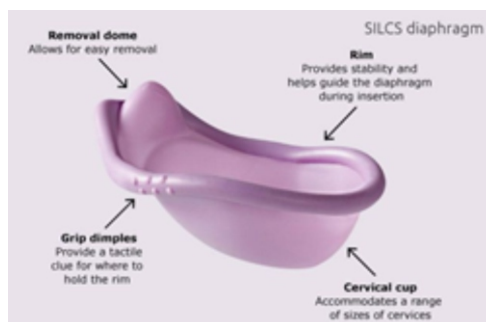

Diaphragms are a reusable, affordable form of birth control, but according to global health nonprofit PATH, they're rarely included in family planning programs, despite a high demand for non-hormonal contraception.

Hormonal Contraceptives

The hormonal contraceptive methods introduced recently include:

- Yasmin®: a combined oral contraceptive pill (COC) with a newer progestin, drospirenone
- NuvaRing®: a contraceptive vaginal ring
- Progestin only vaginal Ring
- Ortho Evra®: a transdermal contraceptive patch
- Seasonale®: an oral contraceptive pill taken in a 12-week regimen
- Ulipristal acetate : Emergency contraceptive pill
- Sayana press : Self-administer subcutaneous DMPA
- Implanon NXT: Modified single rod contraceptive Implants
- LNG-IUS

All of these methods contain combined oestrogen and progesterone or only progestins, with daily dosage release. The mechanism of action, advantages, limitations, indications, usage, side effects, complications, and the time for starting these methods are similar to regular COCs or POCs, with a few exceptions.

Yasmin® Pill

Features

Yasmin, a COC, is available in a 28-pill package and was approved by the U.S. Food and Drug Administration in May 2001. Each active tablet contains a newer progestin, drospirenone 3mg, and oestrogen-ethinyl estradiol, 30 mcg.



Effectiveness

More than 1 million women have used Yasmin to date, with a failure rate of 1-5 percent.

Advantages and Limitations

Apart from being highly effective, safe, and well-tolerated:

- Yasmin provides excellent cycle control with low incidence of breakthrough bleeding and spotting, particularly after the third cycle.
- Blood pressure, lipids, glucose, electrolytes, and haematology values stayed within the normal ranges in the majority of women during the clinical trials. The other advantages of Yasmin are the same as those for currently available COCs.
- Women having hepatic dysfunction, renal insufficiency, or adrenal insufficiency should not take Yasmin.
- Women taking nonsteroidal anti-inflammatory agents, other drugs such as naproxen, potassium-sparing diuretics (spironolactone), acetyl cholinesterase inhibitors, angiotensin II receptor antagonists, and heparin should not take Yasmin. The counselling guidelines and instructions for use of Yasmin and the adverse reactions are same as for other COCs.

Vaginal Ring (NuvaRing®)

Features

In October 2001, the U.S. Food and Drug Administration approved NuvaRing, a vaginal contraceptive ring. NuvaRing is a non-biodegradable, flexible, colourless ring made of a polymer of ethylene vinyl acetate and magnesium stearate.



The outer diameter of the ring is 54 mm and the cross-sectional diameter is 4 mm. The ring contains 11.7 mg of etonogestrel and 2.7 mg of ethinyl estradiol. It releases 120 mcg of etonogestrel and 15 mcg of ethinyl estradiol every day.

How to Use

The ring is left in place for 3 weeks, followed by 1 ring-free week. The ring can be inserted any time during the first 5 days of the menstrual cycle. The ring should be placed in the vagina even if the woman has not finished bleeding, and she should use a backup contraceptive method for 7 days. A new ring should be inserted each month. If the ring comes out during the first 3 weeks of use, it should be washed with lukewarm water and placed again. If the ring-free interval is more than 3 hours, a backup contraceptive method should be used for 7 days. The ring should never be left in the vagina for more than 4 weeks. If left in for more than 4 weeks, pregnancy should be ruled out before inserting a new ring, and the woman should use a backup contraceptive method for 7 days after inserting a new ring.

Advantages and Limitations

- NuvaRing has many advantages. Some are common to COCs and some are unique to the ring.

- Vaginal rings are highly effective as they result in complete suppression of ovulation.
- The steady release of hormones provides exceptional cycle control.
- It is easily inserted and removed by the woman herself.
- Rapid return of fertility on discontinuation makes it a highly acceptable method for the woman and her spouse.
- Because the hormones are absorbed directly into the blood through the vaginal mucosa, the hepatic first pass metabolism of progestin is prevented.
- The ring delivers the lowest dose of ethinyl estradiol as compared to other combined hormonal contraceptives.
- The NuvaRing does not protect against STIs and HIV/AIDS.

Progestogen-only vaginal rings- PVR

In MEC 2015 progestin only vaginal ring are introduced by WHO. Women who breastfeed and are ≥ 4 weeks postpartum, can use without restrictions the progesterone-releasing vaginal ring (PVR) (MEC Category 1). A woman who uses the PVR must be actively breastfeeding (e.g. at least four breastfeeding episodes per day) to maintain the efficacy of the method.

The PVR does not protect against sexually transmitted infections (STIs), including HIV. If there is a risk of STI/HIV, the correct and consistent use of condoms is recommended. When used correctly and consistently, condoms offer one of the most effective methods of protection against STIs, including HIV. Female condoms are effective and safe, but are not used as widely by national programmes as male condoms.

They are less effective than combined rings but have a particular application in lactating women as they are oestrogen-free. A ring releasing progesterone 10mg / day can be used for up to four months; it is on the market in Chile and Peru. Rings using nesterone are particularly apposite due to rapid inactivation when taken orally and so the suckling baby cannot possibly be affected. Nestorone-releasing rings are effective for up to one year.

Transdermal Patch (Ortho Evra®)

Features

The U.S. Food and Drug Administration approved a contraceptive patch in November 2001. The patch is applied on the skin, through which the hormones are absorbed. The patch is marketed with the brand name Ortho Evra.



The patch is 4.5 square cm in size and has three layers: the inner release liner, which should be removed before application, a layer containing hormones, and an outer polyester protective layer. The patch contains 6 mg of progestin, norelgestromin (also called 17-acetylnorgestimate) and 0.75 mg of ethinyl estradiol. The patch releases 120 mcg of norelgestromin and 20 mcg of ethinyl estradiol every day.

Advantages and Limitations

The patch has many advantages over COCs.

Mode of Action

It provides a steady release of hormones resulting in complete suppression of ovulation.

Effectiveness

It is highly effective, with a first year failure rate of 1-2 percent.

How to Use

It can be easily applied on the skin and has been found to be a highly acceptable method among clients.

The patch is very simple and easy to use and women do not require any assistance.

Women weighing more than 198 pounds should not use the patch, as the effectiveness of the patch is reduced in these women.

The user can easily verify the presence of patch, which can reassure her of continued protection.

Method of Use

The patch is applied to clean, dry, intact healthy skin on the buttocks, abdomen, outer arm, or upper torso, but not to the breasts.

The first patch should be applied within the first 5 days of the menstrual cycle, or otherwise be sure that the client is not pregnant and uses backup contraception should be used for 7 days. A new patch should be applied every week for 3 weeks followed by 1 patch-free week.

If the patch falls off for any reason, a new patch should be applied as soon as possible but

within 48 hours. No backup contraception is required. The patch does not fall off easily. Heat, humidity, and exercise do not affect adhesion. The patch may detach completely in up to 2-6 percent of all patches used.

Under no circumstances should the patch-free interval go beyond 7 days between cycles. If this happens, pregnancy should be ruled out before applying a new patch, and a backup method used for 7 days or the option of emergency contraceptive pills should be considered.

In case of skin irritation, the patch should be removed and a new patch applied at a different location until the next change day.

Seasonale®

Features

Seasonale is the continuous birth control pill. It is taken just like the regular active/hormonal pill, continuously for 3 months, and then with inactive pills for 1 week after that. The client will have periods four times in a year.



Advantages

- Fewer periods.
- Lighter periods with less blood flow.
- Some women with menstrual migraines or headaches benefit because they have fewer or less intense periods.

Limitations

- It must be taken daily.
- It does not protect against sexually transmitted infections (STIs).
- It can be difficult for women to be sure they are not pregnant without a monthly period.
- There are some health risks similar to those with all birth control pills:
 - Blood clots, stroke, and heart attack.
 - Cigarette smoking with age above 35 increases the risk of serious side effects.

How to Use

- Like traditional birth control pills, the series of pills contains synthetic hormones, oestrogen, and progestin, which are taken daily to prevent the client from ovulating (releasing an egg to be fertilized). Instead of a true menstrual period that occurs 2 weeks after ovulation, the client will get a "pill period" that may be lighter than a regular period.
- Unlike traditional birth control pills that require 21 days of active pills followed by 7 days of inactive pills, Seasonale allows the woman to take "active" pills continuously for 3 months. During this time, Seasonale prevents the uterine lining from thickening enough to produce a full menstrual period. Every 3 months, the client will take 1 week

of inactive pills to produce a "pill period" that may be lighter than a regular period.

- When the client takes continuous birth control pills, she should expect to have four menstrual periods per year (bleeding when she is taking the seven white pills). However, she will have more bleeding and spotting between menstrual periods than if she were taking a traditional birth control pill with a 28-day treatment cycle.
- For most effective use, the client should take the pill at the same time each day.

Ulipristal Acetate

New emergency contraceptive has been introduced by WHO in MEC 2015. The recommendations are:

- Women who are breastfeeding can generally use UPA (MEC Category 1). Breastfeeding is not recommended for one week after taking UPA since it is excreted in breast-milk. Breast-milk should be expressed and discarded during that time.
- Women who have experienced past ectopic pregnancies can use UPA for ECPs without restriction (MEC Category 1).
- Women with history of severe cardiovascular disease, including ischaemic heart disease, cerebrovascular attack, or other thromboembolic conditions, can generally use UPA for ECPs (MEC Category 2).
- Women with migraines can generally use UPA for ECPs (MEC Category 2).
- Women with severe liver disease, including jaundice, can generally use UPA for ECPs (MEC Category 2).
- Women using CYP3A4 inducers (e.g. rifampicin, phenytoin, phenobarbital, carbamazepine, efavirenz, fosphenytoine, nevirapine, oxcarbazepine, primidone, rifabutin, St John's wort/Hypericum perforatum) can use UPA for ECPs without restriction (MEC Category 1). Strong CYP3A4 inducers may reduce the effectiveness of ECPs.
- There are no restrictions on repeated ECP use for UPA (MEC Category 1).
- Recurrent ECP use is an indication that the woman requires further counselling on other contraceptive options. Frequently repeated ECP use may be harmful for women with conditions classified as Category 2, 3 or 4 for use of combined hormonal contraceptives (CHCs) or progestogen-only contraceptives (POCs).
- There are no restrictions for use of UPA for ECPs in cases of rape (MEC Category 1).
- Women who are obese can use UPA for ECPs without restriction (MEC Category 1).
- ECPs may be less effective among women with BMI \geq 30 kg/m² than among women with BMI < 25 kg/m². Despite this, there are no safety concerns.

Ulipristal acetate was granted marketing authorization by the European Medicines Agency (EMA) in March 2009. The U.S. Food and Drug Administration approved the drug for use in the United States on 13 August 2010, following the FDA advisory committee's recommendation. It is now included in WHO MEC 2015 emergency contraceptive list.

For emergency contraception a 30 mg tablet is used within 120 hours (5 days) after an unprotected intercourse or contraceptive failure. It has been shown to prevent about 62-85% of expected pregnancies, and prevents more pregnancies than emergency contraception with levonorgestrel. Ulipristal acetate is available by prescription for emergency contraception in over 50 countries, with access through pharmacists without a prescription being tested in the United Kingdom.

Adverse effects: Common side effects include nausea, abdominal pain, emesis, dysmenorrhea, pelvic pain, breast tenderness, headache, dizziness, mood swings, myalgia, and fatigue.

Injectable Contraception

SAYANA PRESS- DMPA Subcutaneously:

DMPA subcutaneously (104 mg/0.65 mL) has been introduced by WHO in MEC 2015. Sayana Press is a DMPA-SC formulation available in international market. It is a new type of prefilled, single use syringe could be particularly useful to provide DMPA in the community. These syringes have a short needle meant for subcutaneous injection (that is, injection just below the skin). They contain a special formulation of DMPA, called DMPA-SC. It is meant only for subcutaneous and not for injection into muscle. This formulation of DMPA is available in conventional pre-filled auto disposable syringes and in the Uninject systems in which squeezing a bulb pushes the fluid through the needle (see photo on page). Like all single use syringes, these syringes should be placed in a sharps box after use, and then the sharps box should be disposed of properly.

DMPA-IM and DMPA-SC appear to be therapeutically equivalent; the two formulations demonstrate similar pharmacokinetics, effects on serum estradiol levels and high contraceptive efficacy (1). In addition, similar effects on weight change, bleeding patterns and experience of other adverse effects have been reported among healthy reproductive age users



Recommendations:

Age:

- Young women (menarche to < 18 years) can generally use DMPA (MEC Category 2).
- Women between the ages of 18 and 45 years can use DMPA without restriction (MEC Category 1)
- Women > 45 years old can generally use DMPA (MEC Category 2).

Endometriosis:

- Women with endometriosis can use DMPA without restriction (MEC Category 1).

HIV:

- Women living with HIV who have asymptomatic or mild clinical disease (WHO stage 1 or 2) can use DMPA without restriction (MEC Category 1).
- Women living with HIV who have severe or advanced HIV clinical disease (WHO stage 3 or 4) can use DMPA without restriction (MEC Category 1).

Obesity:

- Women with a body mass index (BMI) ≥ 30 kg/m² can use DMPA without restriction (MEC Category 1).
- Young women (menarche to < 18 years) with a BMI ≥ 30 kg/m² can generally use DMPA (MEC Category 2).
- There is evidence for differential weight gain among normal-weight and obese adolescents who use DMPA, but not those using norethisterone enanthate (NET-EN). However, NET-EN is MEC Category 2 due to evidence regarding potential effects of NET-EN on bone mineral density among adolescents.

Implanon NXT

One-rod implants consist of a single, rod-shaped implant, containing 68 mg etonogestrel, pre-loaded in the needle of a disposable applicator. Implanon NXT differs only slightly from its predecessor Implanon, in that it is radiopaque, and therefore identifiable via x-ray. The insertion trocars for Implanon and Implanon NXT are different so the insertion procedure differs but the pharmacological characteristics are same. One package consists of a single implant containing 68 mg etonogestrel and 15 mg of barium sulfate, which is 4 cm in length and 2 mm in diameter, and is pre-loaded in the needle of a disposable applicator. The sterile applicator containing the implant is packed in a blister pack. The applicator is pictured in **Figure**

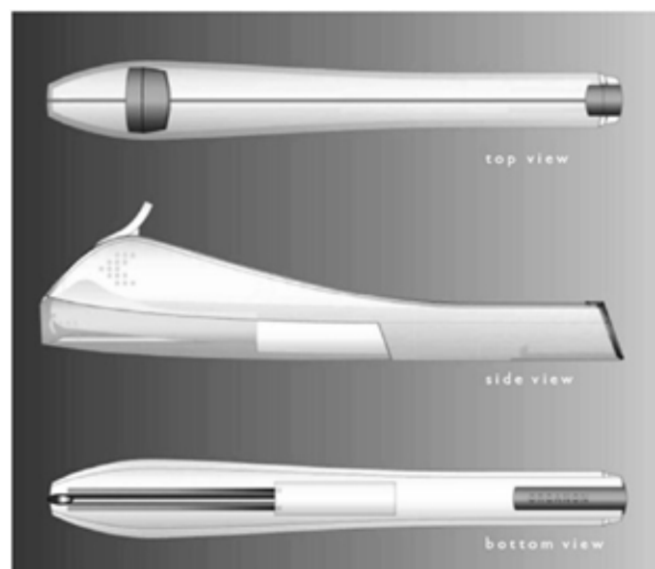

Levonorgesteral Intra Uterine System

Hormonal IUS has been approved by WHO Medical eligibility Criteria 2015 as a recommended method of contraception.

The LNG IUS consist of a plain plastic T shaped frame with a hormone reservoir around the vertical stem. It contain the Levonorgesteral hormone. The effectiveness duration depends upon the amount of hormone present in the cylinder and per day release rate. In international market following types of LNG-IUS are available

1. Mirena- It is a T shaped hormonal IUD that is in the market for long. It contain 52mg of LNG with daily release of approx. 20mcg of hormone. It is effective for 5 years.
2. Liletta- It is also T shaped polyethylene frame with 52 mg of LNG. It has daily release of 18.6mcg of hormone in the uterine body. It is effective for 3 years.
3. Skyla- It is also T shaped device with 13.5mg of LNG in cylinder. It release 14mcg of hormone per day. It is effective for 3 years.
4. Kyleena- The daily release of hormone is 17.5 mcg/ day and It is effective for 5 years.
5. Eloira- The IUS release the hormone at approx. 20mcg /day and it is effective for 5 years.

Intrauterine Contraceptive Devices

■ Long Inserter tube IUCD

It is a new device that contain the same copper 380 A, T shaped IUD with longer string. It is preloaded in a long inserter tube. The long string enables the provider to be sure of insertion. It is manufactured by Pregna International and trial are going on in its insertion technique modification before it come to market.

■ Yuangong IUCD

Features

The Yuangong IUCD is an intrauterine contraceptive device. It is made with high-quality stainless steel and highly pure copper. This IUCD has been designed to suit the shape and dynamics of the uterus, and the content of the material assures safe, long-term use without degeneration. Each of the IUCDs (220 IUCD, 300 IUCD, and 365 IUCD) is available in three different sizes-large, medium, and small-and is impregnated with indomethacin, a nonsteroidal anti-inflammatory drug (NSAID).

Characteristics of Yuangong IUCD

- Made of stainless steel wire, which is easily compatible with the human body.
- Capable of placement in the uterus for more than 20 years without aging and degeneration.
- Possesses moderate elasticity.
- Pure copper is released inside.
- Thread-less.
- No effect on sexual life.

- Easy insertion and removal.
- With impregnation of indomethacin, pain/bleeding and other side effects are reduced.

Advantages

- It springs to the uterine fundus when inserted.
- It cannot be easily displaced or expelled.
- It returns to its original shape when the uterus relaxes.

Limitations

- Uterine cramps and/or abdominal pain may occur.
- Nulliparous women are more prone to syncope, bradycardia, and other neurovascular episodes during or immediately after insertion or removal of this IUCD.
- Breakthrough bleeding and/or spotting often occurs during the first cycle and may recur for several subsequent cycles.
- Increased duration of menstruation and an increase in menstrual blood loss may occur, especially during the first few cycles.
- Dysmenorrhoea may occur or be aggravated.
- Does not protect against HIV infection or any of the STIs.

Contraindications

- Pregnancy or when there is a possibility of pregnancy
- Inflammation of the genitalia, such as acute and chronic pelvis infection, vaginitis, acute cervicitis, and severe cervical erosion
- Heavy or irregular uterine bleeding
- Endometriosis
- Uterine cavity is less than 5.5 cm
- Severe dysmenorrhoea, tumour of the female genitalia tract, and severe uterine deformity
- In patients with untreated STIs or those who have not yet recovered from the infection
- In patients with history of ectopic pregnancy, women with severe vagus reflex, or who fainted during uterine operation

Male Methods

Male Hormonal Methods

Many methods that act by inhibiting spermatogenesis are currently under development.

For example:

- Exogenous progestin or gonadotrophin-releasing hormone (GnRH) antagonist to suppress follicle-stimulating hormone (FSH) and luteinizing hormone (LH), thereby decreasing spermatogenesis.
- Exogenous testosterone (injectable, patch, or implant) combined with a slow-release progestin implant.

Non-Hormonal Methods

- Anti-sperm compounds, e.g., gossypol from cottonseed oil and triptolide.
- Immuno-contraception methods based on interference of the reproductive process by products of an immune reaction.
- Temporary sterilization by injecting the vas deferens with a polymer to block sperm transport

15

POSTPARTUM FAMILY PLANNING

Introduction

The role of postpartum family planning (PPFP) in improving the health of mothers and babies (see Chapter 3 on Healthy Timing and Spacing of Pregnancy [HSTP]) and in decreasing both maternal and neonatal mortality rates is well documented. A wide range of contraceptive methods is appropriate for postpartum women and can be safely used also by the breastfeeding mother. Systematic and routine provision of family planning (FP) counselling in the antenatal and postpartum periods has been shown to be critically important to the timely initiation of FP following childbirth, miscarriage, and abortion.

Policy

All pregnant and postpartum women—including women who are post-miscarriage or postabortion should have access to PPFP counselling and services.

To ensure timely initiation of an FP method appropriate to the woman's breastfeeding status and fertility intentions, FP counselling (including information about HTSP) should be provided to pregnant women and their families wherever they receive medical care: FP clinics, antenatal clinics, birthing facilities, postpartum and postnatal care facilities, and other facilities like Basic Health Units and Family Welfare Centres where mothers receive routine health care. Basic postpartum FP care and services should:

- Promote HTSP.
- Encourage exclusive breastfeeding and the lactational amenorrhoea method (LAM).
- Counsel on return to fertility.
- Offer a wide range of contraceptive choices.
- Integrate FP with other maternal and child health programs, including childhood immunization and the prevention of mother-to-child transmission of HIV (PMTCT).

Standards

The following standards will be observed:

- The client should be given full information and receive counselling about:
 - Available FP methods and HTSP during pregnancy.
 - Available FP methods and HTSP following childbirth, miscarriage, or abortion.
 - Breastfeeding and LAM during pregnancy and following childbirth.
 - Transitioning to another FP method when no longer using LAM.
- The client's right to make a free and informed choice regarding eventual family size and fertility will be respected.

Note: A wide range of FP methods including long-acting and permanent methods should be available in birthing facilities and other sites where postpartum and postnatal services are offered to mothers and babies. An appropriate postpartum/postabortion FP method should be provided to the client at her request.

Overview of Postpartum/Postnatal Family Planning

Postpartum/postnatal contraception is the initiation and use of FP methods during the first year after childbirth or after a miscarriage/abortion. When used to describe the period after childbirth, the postpartum/postnatal period is generally divided into the following four categories:

- **Post-placental**-Within the first 10 minutes after delivery of the placenta
- **Immediate postpartum**-Within 48 hours after delivery
- **Early postpartum**-From 48 hours up to 4 weeks after delivery
- **Extended postpartum**-From 4 weeks up to 1 year after delivery

Healthy timing and spacing of Pregnancy

Following are the three components of HTSP:

- After a live birth, the recommended minimum interval before attempting the next pregnancy is at least 24 months (but not more than 5 years) in order to reduce the risk of adverse maternal, perinatal, and infant outcomes.
- After a miscarriage or induced abortion, the recommended minimum interval before attempting the next pregnancy is at least 6 months in order to reduce the risk of adverse maternal and perinatal outcomes.
- Delay timing of the first pregnancy in adolescents until age 18 to reduce the risk of adverse maternal, perinatal, and infant outcomes.

Delaying vs. spacing vs. limiting

Family planning interventions postpartum can be divided into three broad categories:

- **Delaying:** Family planning for the woman who is too young or not yet ready to start having children.
- **Spacing:** Family planning for the mother who either plans to have more children or is not sure what her final family size will be.

- **Limiting:** FP for the mother who plans to have no more children.

Return of Fertility in Postpartum Period

The return of fertility in postpartum is unpredictable and can occur before menses returns. PFP counselling with selection of an appropriate method by the client during pregnancy or shortly after childbirth.

- For breastfeeding women:
 - The period of infertility is longer for women who practice exclusive or breastfeeding. After 6 months, when the infant is taking complementary foods and breastfeeds less, return of fertility becomes unpredictable and ovulation may occur prior to menses.
- For non-breastfeeding women:
 - Menses will resume on an average of 4-6 weeks after delivery. Most women will ovulate before menstruation occurs.
- For women after miscarriage or abortion:
 - Ovulation may occur as early as 2 weeks after a miscarriage or abortion.

Family Planning methods for Postpartum Women

Figure 15-1. Initiation of Family Planning Methods

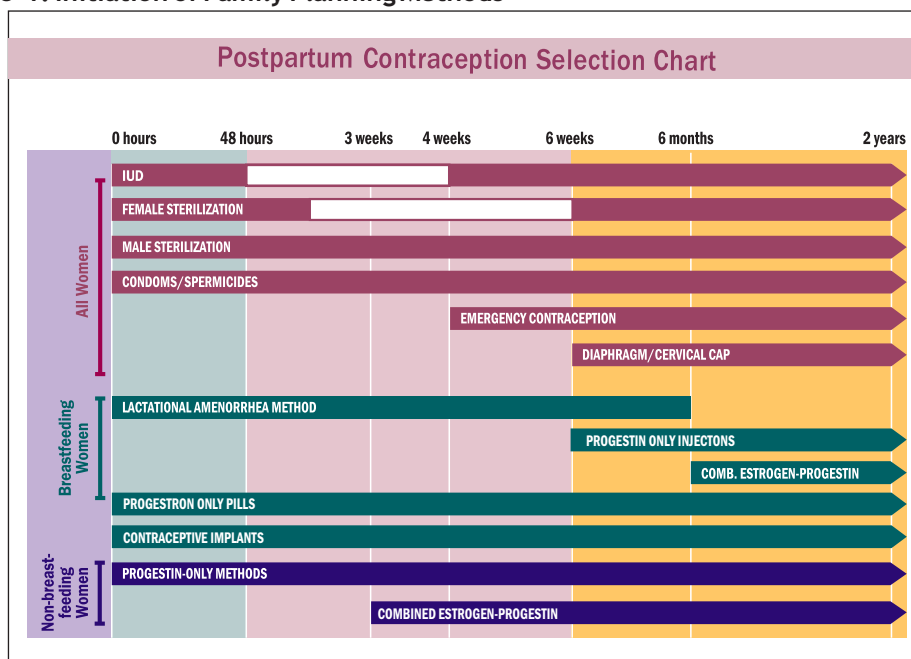

source: georgetown university, institute for reproductive Health, and Jhpiego. 2009. Lactational Amenorrhea Method (LAM): A Learning Resource Package for Family Planning Service Providers and Trainers. georgetown university: Washington, D.C.

lactational amenorrhea method

LAM is a temporary method of contraception linked to breastfeeding and is more than 98 percent effective in preventing pregnancy.

The essential criteria for LAM effectiveness are:

- Baby is less than 6 months old, and
- Menses has not resumed, and
- Baby is exclusively breastfed.

Women using LAM should transition to another FP method by 6 months postpartum or whenever other LAM criteria are no longer met. Transitioning should be discussed at every counselling visit. Studies have shown that women who use LAM are more likely to use a modern method of contraception at 6-12 months postpartum.

LAM can be used in combination with other FP methods to enhance effectiveness including the postpartum intrauterine contraceptive device (IUCD), progestin-only pills/injectables/implants, and barrier methods such as condoms.

Postpartum women should be specifically counselled that if any component of LAM is not met-the baby is older than 6 months or menstrual flow has returned or the baby is no longer exclusively breastfed-immediate transition to another FP method is advised.

Postpartum Intrauterine Contraceptive Device (PPIUCD)

There are several points during the postpartum period when an IUCD may be inserted in breastfeeding or non-breastfeeding women:

- **Postplacental insertion:** Within 10 minutes after delivery of the placenta.
- **Immediate postpartum insertion:** Within 48 hours of delivery of the placenta.
- **Trans-cesarean insertion:** During cesarean section, after the uterine cavity has been explored manually and following delivery of the placenta.
- **Interval insertion:** At 4-6 weeks postpartum.
- Postplacental, immediate postpartum, and trans-cesarean insertion of the IUCD is generally performed using a long Kelly forceps, and requires a provider with specific training in postpartum insertion. Proper insertion technique is important in order to avoid expulsion
- Postpartum insertion of the IUCD should not be attempted in the presence of haemorrhage or puerperal sepsis (infection of the reproductive organs during the first 6 weeks postpartum).
- Postplacental IUCD insertion does not interfere with or change the steps of active management of third stage of labor.
- Interval insertion at 4 weeks postpartum is performed using an inserter with the "no-touch" technique and requires a provider with specific training in interval insertion. (refer to chapter 10 IUCD) Insertion of the IUCD is not recommended between 48 hours and 4 weeks postpartum because of an increase in the risk of perforation and infection. (World Health Organization Medical Eligibility Criteria category 3)
- Insertion technique following miscarriage or abortion varies by trimester. **First-trimester miscarriage or abortion** may be followed by immediate insertion of the IUCD using an inserter with "no-touch" technique and requires a provider with specific training in interval insertion. (Refer to Chapter 10- IUCD)

Second- trimester miscarriage or abortion may be followed by immediate insertion of the IUCD using a ring or other long Kelly forceps and requires a provider with specific training in postpartum insertion. If a specifically trained provider is not available, insertion after second-trimester miscarriage or abortion should be delayed for at least 4 weeks. Offer woman other FP method.

If the IUCD is inserted within 12 days after first- or second-trimester abortion or miscarriage, there is no need for a backup method.

- An IUCD may be inserted more than 12 days after first- or second- trimester miscarriage or abortion only if it is reasonably certain the client is not pregnant, with no need for a backup method.
- If an abortion-related infection of the uterus (septic abortion) is present, treat or refer appropriately and help the client choose another method. If she still wants the IUCD, it can be inserted after the infection has completely cleared up.

PPIUCD Services-Key Elements

Key elements of PPIUCD services are as follows (some may happen in a different order or overlap with others):

- PFPF education/counseling: The woman receives basic information about healthy spacing of pregnancies (and limiting, if desired) and the PFPF methods available to her (e.g., effectiveness, duration of protection); the woman's fertility goals and individual circumstances are discussed to help her choose a method that is well-suited to her needs.
- Method-specific counseling: Women interested in a certain method, such as the PPIUCD, are provided more specific information about the method (e.g., side effects, warning signs).
- Annotation of the woman's PFPF choice on her record: If a woman has chosen a method, her choice is documented prominently at the top of her medical record-to inform other providers of her decision. This may be done some time after counseling, after the woman has had a chance to discuss the issue with her partner or others.
- Initial screening: A woman who chooses the PPIUCD is screened for existing characteristics/ conditions (according to WHO's MEC for IUCDs) that would make the IUCD a poor choice for her, or medical reasons why the method should be withheld.
- First confirmation of the woman's choice of the PPIUCD: When the woman presents for delivery, the provider confirms that she still wants an IUCD and when she wants it inserted. The provider reassures or counsels the woman, as needed. (Again, though, PFPF/PPIUCD counseling should occur during the antenatal period, whenever possible.)
- Ensuring that supplies and instruments are available and ready for use: The provider then ensures that a sterile Copper T IUCD and the supplies/ instruments and light source needed are available and ready for use.
- Managing labor and delivery: Including using a partograph, performing AMTSL and addressing any problems that may arise, obstetric care is integrated with PPIUCD

- services and takes precedence when appropriate.
- Second screening: After the birth, the woman is screened for conditions resulting from labor and delivery that would make the IUCD a poor choice for her, or medical reasons why the method should be withheld.
 - Second confirmation of the woman's choice of the PPIUCD: Immediately before the PPIUCD is inserted, the provider tells the woman she/he is about to insert the IUCD if the woman is ready. This helps prepare the woman and reconfirms her choice.
 - Insertion of the PPIUCD: After the final determination has been made that the woman will have an IUCD inserted, the supplies/instruments are arranged and the IUCD is removed from the package using the "no-touch" technique . The IUCD is then gently inserted according to recommended practices, either immediately postpartum (postplacental, intracesarean) or early postpartum (up to 48 hours).
 - Post-insertion counseling: The woman receives information about side effects, warning signs and when to return to the clinic for follow-up. This should be integrated with routine postpartum/newborn care.
 - Follow-up: At 4 to 6 weeks after the birth, the woman returns for routine PPIUCD follow-up. She is screened for potential problems related to the IUCD; any problems are managed or referred.
 - Clients are treated with kindness, courteousness and respect; the woman who chooses the PPIUCD should do so freely and should be provided that method, if appropriate, in accordance with the latest evidence-based recommendations and global standards of care
 - Providers and other health staff employ infection prevention practices as appropriate, in accordance with global standards.

“Optimal PPIUCD Service Scenario”—Antenatal Introduction to the PPIUCD with Immediate Postpartum Insertion

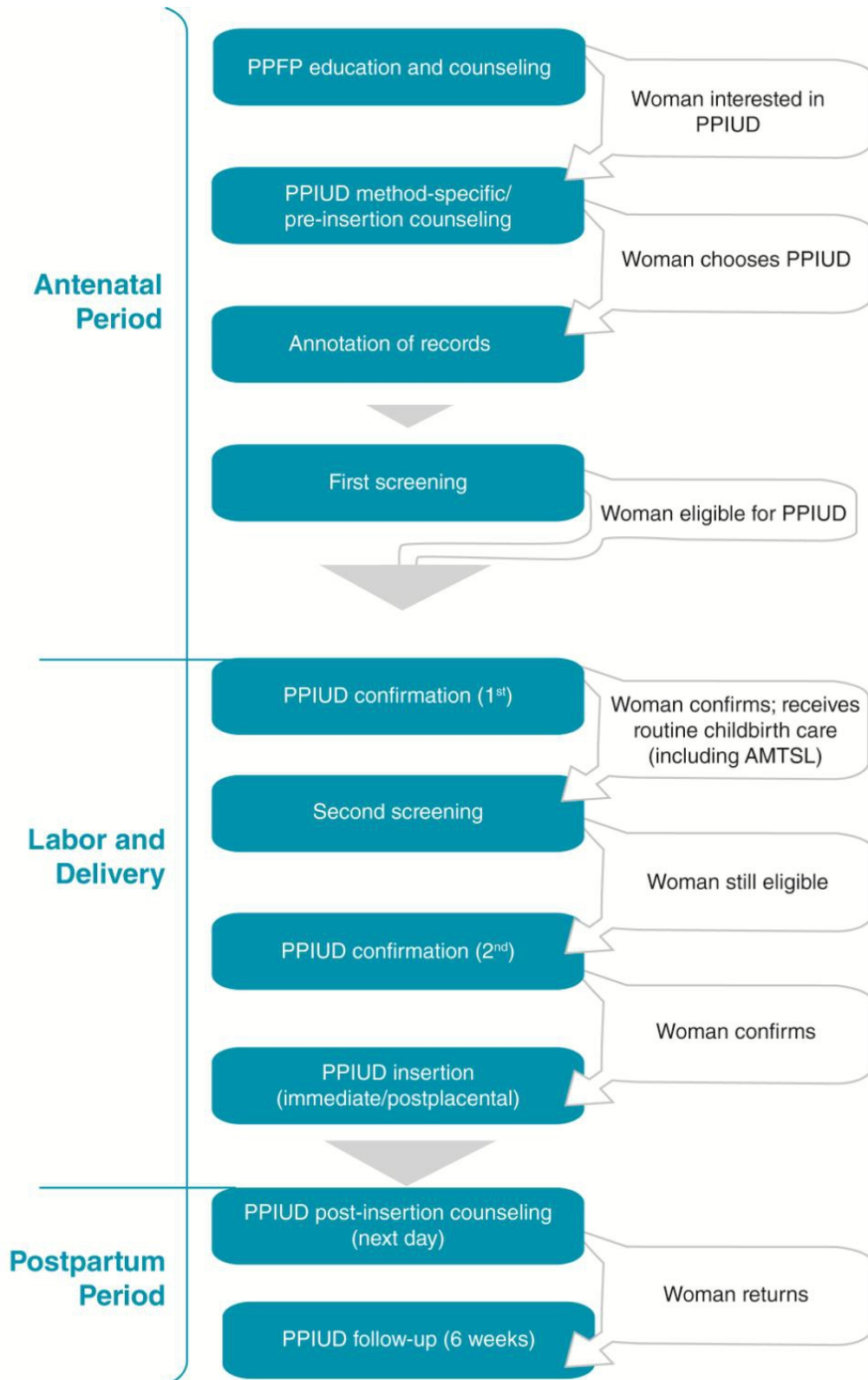

Job Aid for Second PPIUCD Screening

In preparation for insertion of the IUCD, confirm the following information about the woman and her clinical situation:

Ask the woman whether she still desires the IUCD for PPFPP	<input type="checkbox"/> No	<input type="checkbox"/> Yes
Review her medical record and be certain that:		
● Her initial screening shows that an IUCD is an appropriate method for her	<input type="checkbox"/> No	<input type="checkbox"/> Yes
● She has had family planning counseling while not in active labor and there is evidence of consent in her chart OR	<input type="checkbox"/> No	<input type="checkbox"/> Yes
● She is being counseled in the postpartum period	<input type="checkbox"/> No	<input type="checkbox"/> Yes
Review the course of her labor and delivery and ensure that <u>none</u> of the following conditions are present:		
Confirm that the client received the active management of third stage of labor (AMSTL). This includes:	<input type="checkbox"/> Yes	<input type="checkbox"/> No
● Oxytocic is given within one minute of the delivery after excluding the second twin		
● Cord is clamped, placenta delivered by controlled cord traction (CCT) with counter-traction on the fundus		
● Fundal massage		
If planning an <i>immediate postplacental or intracesarean insertion</i> check that <u>none</u> of the following conditions are present:		
● Chorioamnionitis (during labor)	<input type="checkbox"/> Yes	<input type="checkbox"/> No
● More than 18 hours from rupture of membranes to delivery of baby	<input type="checkbox"/> Yes	<input type="checkbox"/> No
● Unresolved postpartum hemorrhage	<input type="checkbox"/> Yes	<input type="checkbox"/> No
If planning an <i>early postpartum insertion</i> , check that <u>none</u> of the following conditions are present:		
● Puerperal sepsis	<input type="checkbox"/> Yes	<input type="checkbox"/> No
● Postpartum endometritis/metritis	<input type="checkbox"/> Yes	<input type="checkbox"/> No
● Continued excessive postpartum bleeding	<input type="checkbox"/> Yes	<input type="checkbox"/> No
● Extensive genital trauma where the repair would be disrupted by early postpartum placement of an IUCD	<input type="checkbox"/> Yes	<input type="checkbox"/> No
Confirm that sterile instruments are available*	<input type="checkbox"/> No	<input type="checkbox"/> Yes
Confirm that IUCDs are available and accessible on the labor ward*	<input type="checkbox"/> No	<input type="checkbox"/> Yes
	If ANY box is checked in this column, defer insertion of the IUCD and provide the woman with information about another method.	If ALL the boxes in this column are checked, then proceed with IUCD insertion.

Instruments and Equipment Required for PPIUCD Insertion

Following is the list of equipment and instruments required for PPIUCD insertion. All of the instruments must be either sterilized or high-level disinfected before use:

Table 10-1. Instruments and Equipment Required for IUCD Insertion and Removal

Instruments/Equipment	Quantity	Instruments/Equipment	Quantity
Cheatele forceps	1	Container for cheatele forceps	1
Sponge forceps	1	Covered tray for sterilized instruments	1
Long Kellys forceps	1	Covered jar for cotton swabs	1
SIMS speculum	1	Bowl for antiseptic solution	1
Pyodene	1	Kidney tray for used instruments	1
Drape Clothes, Sterile gloves, cotton swabs	2	Autoclave or boiler for sterilization or high-level disinfection of instruments	1
IUCD sterile pack	1/As required	P/V lamp, torch/emergency light	1
PPIUCD insertion table	1	Mackintosh	1

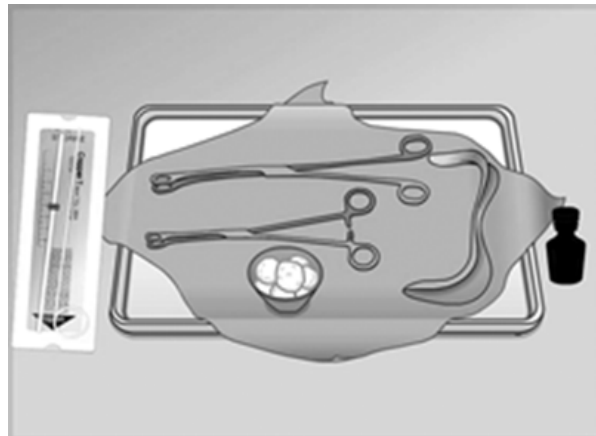

Clinical Technique for Insertion of the PPIUCD

This section provides step-by-step guidance on different types of PPIUCD insertion: during the immediate postpartum period: postplacental (1) instrumental (2) cesarean (manual) insertion; and

The goal of all types of insertions is to insert the IUCD safely, in a manner that reduces the risk of spontaneous expulsion.

Tips for Reducing Spontaneous Expulsion

Right Time:

- Recommend postplacental and intracesarean insertions, which have the lowest expulsion rates.

Right Technique/Instrument:

- “Elevate” the uterus to straighten its lower segment.
- Use an instrument that is rigid enough to negotiate the vagino-uterine angle, and long enough to reach the fundus (such as a Kelly or ring forceps).
- If using an instrument:
 - Keep instrument closed until the fundus is reached.
 - Sweep instrument to the side after placing the IUCD.
 - Keep instrument open while withdrawing.
- Confirm proper IUCD placement.

Postplacental Instrumental Insertion

Postplacental instrumental insertion of the IUCD is done immediately following delivery of the placenta, typically within 10 minutes using a Kelly forceps. The woman has been counseled and prepared prior to the start of active labor, preferably during the antenatal period. The woman is in the labor/delivery room and has not yet gotten up from the delivery bed. She is still in the lithotomy position following delivery, or assumes the lithotomy position if an alternative position has been used for delivery. The insertion takes place immediately following AMTSL and the delivery of the placenta

■ Tasks to Perform before Active Labor and Delivery

- Review the woman's medical record to ensure that she has chosen the PPIUCD.
- Ensure that she has been appropriately counseled and screened for PPIUCD insertion.
- Explain that you will insert the IUCD immediately following delivery of the baby and placenta and answer any questions the woman might have; provide reassurance, as needed.
- Once the woman has confirmed that she wants the PPIUCD, obtain a PPIUCD kit/tray, get the correct sterile instruments, supplies, light source and sterile pack of IUCD for the procedure.
- After labor and delivery including performing AMTSL-(Oxytocic is given within one minute of the delivery after excluding the second twin, cord is clamped, placenta delivered by controlled cord traction (CCT) with counter-traction on the fundus followed by fundal massage), screen for delivery-related conditions that preclude insertion of IUCD now:
 - Prolonged rupture of membranes for more than 18 hours
 - Chorioamnionitis
 - Unresolved postpartum hemorrhage
- Before continuing with the second screening, perform infection prevention measures as appropriate
- Inspect perineum, labia and vaginal walls for lacerations.
 - If there are lacerations and they are bleeding, apply a clamp to the bleeding areas to stop the bleeding and proceed with the IUCD insertion procedure.
 - Repair lacerations, if needed, after the procedure.

■ Tasks to Perform before Insertion

- If the second screening has revealed no conditions that contraindicate insertion of the IUCD at this time, ensure that the woman is ready to have an IUCD inserted. Answer any questions the woman might have; provide reassurance, as needed.
- Open the PPIUCD kit/tray and arrange insertion instruments and supplies in a sterile field. Keep the IUCD in its sterile package to side of the sterile field. Place a dry, sterile cloth on the woman's abdomen.
- Gently insert the Simms speculum and visualize the cervix by depressing the posterior wall of the vagina and clean the cervix and vagina with antiseptic solution two times, using two gauzes

- Gently grasp the anterior lip of the cervix with the ring/sponge holding forceps.
- Open the sterile package of the IUCD from the bottom, by pulling back the plastic cover approximately one third of the way. Remove everything except the IUCD from the package
- With your dominant hand, use the placental Kelly forceps to grasp the IUCD inside the sterile package. Gently lift the anterior lip of the cervix using the ring forceps, adjusted to one notch.
- While avoiding touching the walls of the vagina, insert the placental forceps-which are holding the IUCD-through the cervix and into the lower uterine cavity.
 - Gently move the IUCD further into the uterus, toward the point where slight resistance is felt against the back wall of the lower segment of the uterus. Be sure to keep the placental forceps firmly closed.
 - Lower the ring forceps and gently remove them from the cervix; leave them in the sterile field
- "Elevate" the uterus:
 - Place the base of your nondominant hand on the lower segment of the uterus (midline, just above the pubic bone with the fingers toward the fundus).
 - Through the abdominal wall, push the entire uterus superiorly (in the direction of the woman's head).
 - Maintain this position to stabilize the uterus during insertion.
- Keeping the forceps closed, advance the IUCD by:
 - Gently moving the IUCD upward toward fundus, in an angle toward the umbilicus.
 - Lowering the dominant hand (the IUCD/forceps-holding hand), so that the forceps can pass easily through the vagino-uterine angle.
 - Following the contour of the uterine cavity. If significant resistance is felt before the fundus is reached, the provider should try repositioning the uterus
- Continue gently advancing the forceps until the uterine fundus is reached, when you will feel a resistance. Confirm that the end of the forceps has reached the fundus
- While continuing to stabilize the uterus, open the forceps, tilting them slightly toward midline, to release the IUCD at the fundus
- Keeping the forceps slightly open, slowly remove them from the uterine cavity, being careful not to dislodge the IUCD. Do this by:
 - Sweeping the forceps to the side wall of the uterus, and
 - Sliding the instrument against the side of the uterine wall.
- Keep stabilizing the uterus until the forceps are completely withdrawn. Place the forceps aside, in the sterile field.
- Examine the cervix to see whether any portion of the IUCD or the IUCD strings are protruding from the cervix.
- If the IUCD or the IUCD strings are seen protruding from cervix:
 - Remove the IUCD using the same forceps used for the first insertion;
 - Position the same IUCD in the forceps inside the sterile package (as in Steps 18 and 19); and reinsert the device

■ Tasks to Perform after Insertion

- Remove all instruments and place them in a 0.5% chlorine solution
- Allow the woman to rest for a few minutes. Support the initiation of routine postpartum care, including immediate breastfeeding as appropriate.
- Dispose of waste materials in the appropriate container
- Process gloves prior to removal and disposal
- Perform hand hygiene.
- Tell the woman that the IUCD has been successfully placed and provide her with post-insertion counseling,
- Record information in the woman's chart or record. Attach an IUCD card to the chart/record, for the woman to take home with her upon discharge.
- Record information in the procedure room register

Intra-cesarean Insertion

For intracesarean insertion, the woman has been counseled and prepared prior to the start of the operation, preferably during the antenatal period. She will still be in the operating theatre, in the lithotomy position on the operating table. Typically, manual insertion is sufficient (as opposed to instrumental insertion) because the provider can easily reach the uterine fundus. After the placenta is removed, the provider:

- Holds the IUCD between the index and middle fingers of the hand, passes it through the uterine incision and places it at the uterine fundus;
- Slowly withdraws the hand, ensuring that the IUCD remains properly placed; and
- Closes the uterine incision, taking special care not to incorporate the IUCD strings into the suture.

Note: The strings can be pointed toward the cervix but should NOT be pushed through the cervical canal. This helps prevent both uterine infection (caused by contamination of the uterine cavity with vaginal flora) and displacement of the IUCD from the fundus (caused by drawing the strings downward toward the cervical canal).

Early Postpartum Insertion

Early postpartum insertion is done after the immediate postplacental period has passed but within 48 hours of the birth. If the woman has not yet received counseling, a designated family planning counselor or postpartum caregiver can provide group PFP education/counseling on the postpartum ward, followed by individual PPIUCD counseling to women who are interested in the method. The same postpartum caregiver or another trained provider can insert the IUCD in a procedure or examination room on the postpartum ward. It is preferable that postpartum insertion be done within 24 hours of birth—for example, on the morning of postpartum Day 1, rather than Day 2—to reduce expulsion rates and also to avoid logistical issues at the time of postpartum discharge.

When to Return

Before discharge, the following danger signs should be highlighted. The client should be advised to call or return to the facility immediately for assessment if any of these signs occur:

- Heavy vaginal bleeding
- Severe lower abdominal discomfort
- Fever
- Not feeling well

Reminder Card for the PPIUCD Client

If possible, give the client a card with the following information in writing:

- Type of IUCD inserted
- Date of IUCD insertion
- Month and year when IUCD will need to be removed or replaced
- Date of postpartum/PPIUCD follow-up visit
- Where to go or call if she has problems or questions about her IUCD

The client should also call or come in if any of the following occur:

- Unusual vaginal discharge is present.
- IUCD expulsion is suspected-woman can either feel IUCD in the vagina or has seen it expelled from the vagina.
- She has any other problems/questions related to her IUCD.
- She wants the IUCD removed or 12 years have elapsed since IUCD insertion.

Routine Follow-Up Care for PPIUCD Clients

Key objectives of follow-up care are to:

- Assess the woman's overall satisfaction with the IUCD.
- Identify and manage potential problems.
- Address any questions or concerns the woman may have.
- Reinforce key messages regarding removal and duration of action.

Follow-up for women who receive an IUCD in the immediate or early postpartum period should be integrated with postpartum care per global standards/local protocols.

If the IUCD has been expelled, offer the client another contraceptive method or plan to insert another IUCD, if she wishes. The IUCD may be reinserted the same day as expulsion if: there is no sign of infection; pregnancy is not suspected; and it is NOT between 48 hours and 4 weeks after the client's delivery.

Guidelines for IUCD Removal

IUCD removal is usually an uncomplicated and relatively painless routine procedure. Unless an IUCD is removed for a medical reason or because the woman wishes to discontinue the method, a new IUCD can be inserted immediately after removing the old one, if she so desires. Appropriate assessment and care, before and after the procedure, depend on the reason for IUCD removal, and whether the woman is having another IUCD inserted or is starting a different method. Use proper infection prevention practices.

Before Removing the IUCD

- Ask the woman her reasons for having the IUCD removed:
 - If the woman wants her IUCD removed for personal reasons (or offers no reason at all), remove her IUCD. The woman has a right to discontinue the method at any time, regardless of the reason.
 - If the woman is having her IUCD replaced (i.e., at the end of its effective life), ensure that she has undergone appropriate assessment to determine whether she is eligible for IUCD reinsertion at this time.
 - If she is having the IUCD removed for medical reasons (e.g., pregnancy, dangerously heavy menstrual bleeding), ensure that she has undergone the appropriate assessment to determine whether routine IUCD removal is safe for her at this time. Refer for special removals, if needed.
 - If she will be starting a different method, ask when her last menstrual period began. This will help determine whether she will need to use a back-up method.
- Ensure that she understands the following key points about having her IUCD removed, as appropriate:
 - "You can get pregnant again immediately after IUCD removal."
 - "If you do not want to become pregnant, you should have another IUCD inserted immediately or start another contraceptive method."
 - "No rest period is needed between IUCDs."
 - Review her reproductive goals and need for protection against STIs.
 - Help her choose a different contraceptive method, if appropriate.

Note: For routine IUCD removals (especially if replacing the IUCD), removal may be easier during the woman's menstrual period, when the cervix softens. However, IUCDs can be removed at any time during the woman's menstrual cycle.

Removing the IUCD

Using gentle, "no-touch" (aseptic) technique throughout, perform the following steps:

STEP 1: Prepare the client:

- Give the woman a brief overview of the procedure, encourage her to ask questions, and provide reassurance as needed.
- Remind her to let you know if she feels any pain.

STEP 2: Put new/clean examination or HLD surgical gloves on both hands.**STEP 3: Insert an HLD (or sterile) speculum and visualize the cervix and the IUCD strings.**

- If the strings cannot be seen, manage as missing strings (Appendix I).

STEP 4: Cleanse the cervix and vagina with an appropriate antiseptic: Thoroughly apply an appropriate antiseptic (e.g., povidone iodine or chlorhexidine) two or more times to the cervix (wiping from inside the os outward) and vagina. If povidone iodine is used, ensure that the woman is not allergic to iodine and wait 2 minutes for the solution to act.

STEP 5: Alert the woman immediately before you remove the IUCD:

- Ask her to take slow, deep breaths and relax.
- Inform her that she may feel some discomfort and cramping, which is normal.

STEP 6: Grasp the IUCD strings and apply gentle traction:

- Grasp the strings of the IUCD with a high-level disinfected (or sterile) narrow forceps (Figure I-1, Left panel).
- Apply steady but gentle traction, gently pulling the strings toward you with the forceps (Figure I-1, Right panel). (The device can usually be removed without difficulty.)
 - If the strings break off but the IUCD is visible, grasp the device with the forceps and remove it.
 - If removal is difficult, do not use excessive force. See box below for guidance on managing this problem.

Figure I-1 Removing the IUCD

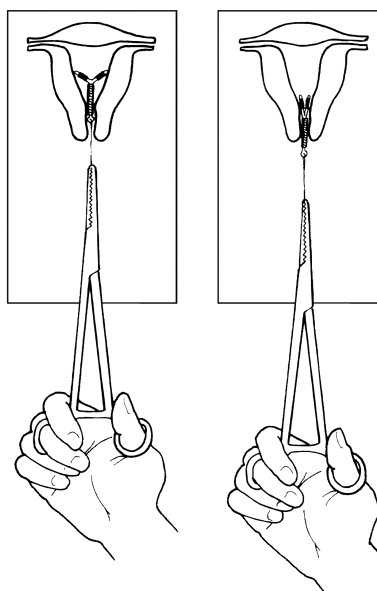

Guidelines for Difficult IUCD Removals

If you have partially removed the IUCD but have difficulty drawing it through the cervical canal:

- Attempt a gentle, slow twisting of the IUCD while gently pulling.
- Continue as long as the woman remains comfortable.
 - If the IUCD can still not be removed, refer the woman to a specially trained provider who can dilate the cervix.

If there seems to be a sharp angle between the uterus and cervix:

- Place a high-level disinfected (or sterile) tenaculum on the cervix, and apply gentle traction downward and outward.
- Attempt a gentle, slow twisting of the IUCD while gently pulling.
- Continue as long as the woman remains comfortable.
 - If the IUCD can still not be removed, refer the woman to a specially trained provider who can dilate the cervix.

STEP 7: Show the woman the IUCD, and place it in 0.5% chlorine solution for 10 minutes for decontamination.

STEP 8: Insert a new IUCD, if the woman so desires and there are no precautions to continued use. If she is not having a new IUCD inserted, gently remove the speculum and place it in 0.5% chlorine solution for 10 minutes for decontamination.

After Removing the IUCD

- Ask the woman how she is feeling, and whether she is experiencing any of the following symptoms:
 - Nausea
 - Mild-to-moderate lower abdominal pain/cramping
 - Dizziness or fainting (rare)
 - If the woman is experiencing any of these symptoms, provide reassurance and allow her to remain on the examination table to rest until she feels better.

Important: Although most women will not experience problems after IUCD removal, all women should remain at the clinic for 15 to 30 minutes before being discharged as a precaution.

If the woman is starting a new contraceptive method, it should be provided now—along with a back-up method if needed.

Identification and management of common side effects and problems encountered at follow-up

Problem (Signs/Symptoms)	Management
<p>Changes in Menstrual Bleeding Patterns</p> <ul style="list-style-type: none"> ● Increase in amount of menstrual bleeding above what is usually expected in the postpartum period ● Increase in duration of menstrual bleeding above what is usually expected in the postpartum period ● Spotting/light bleeding between periods once they resume postpartum 	<ul style="list-style-type: none"> ● Determine severity of symptoms: how much more bleeding than usual; how long have symptoms lasted; when did the symptoms start; are they accompanied by other symptoms (e.g., pain, fever); how well is the woman tolerating them? ● If symptoms are mild and consistent with uterine involution, provide reassurance. ● Where appropriate, rule out other gynecologic pathology and refer her to a qualified practitioner, if indicated. ● Where appropriate, rule out pregnancy by history or available testing. ● Where appropriate, check for IUCD expulsion: palpate strings on bimanual exam or by using a speculum. ● If client desires treatment, offer a short course of NSAIDs, continued for 3 to 5 days. If heavy bleeding is the problem, aspirin should not be used because it has an anti-blood-clotting effect. ● If bleeding is persistently heavy and prolonged or associated with clinical or laboratory signs consistent with severe anemia (e.g., pallor, weakness), offer iron replacement therapy and consider IUCD removal with the patient's consent. ● If client finds bleeding unacceptable, remove IUCD and counsel her regarding alternative methods of family planning.
<p>Cramping or Pain</p> <ul style="list-style-type: none"> ● Increased cramping or pain that may or may not be associated with menstruation 	<ul style="list-style-type: none"> ● Determine severity of symptoms: how severe is pain; how long has pain lasted, when did pain start; is pain accompanied by other symptoms (e.g., bleeding, fever); how well is the woman tolerating the pain? ● Perform an appropriate assessment, including: vital signs, abdominal and pelvic examination and appropriate laboratory studies (pregnancy test; complete blood count [CBC], cultures) to rule out other possible causes of pain or infection; partial IUCD expulsion, such as: uterine perforation; pregnancy/ectopic pregnancy; urinary tract infection. If appropriate, see section for management of infection (page 49) and pregnancy with the IUCD in place (page 51). ● If symptoms and physical findings are mild and consistent with postpartum uterine involution, reassure the woman. ● Recommend a short course of NSAIDs immediately before and during menstruation to help reduce menstrual pain and cramping that are bothersome to the client. ● If cramping or pain is severe, remove the IUCD. If the IUCD was improperly placed, partly expelled or appeared to be abnormal/distorted, discuss insertion of a new IUCD with the client. If the IUCD appeared to be normal and in proper position, counsel the woman regarding alternative forms of family planning.

<p>Infection</p> <ul style="list-style-type: none"> ● Lower abdominal pain ● Fever ● Painful intercourse ● Bleeding after sex or between periods once resumption of normal monthly menses has occurred postpartum ● New onset of pain associated with periods ● Abnormal vaginal discharge ● Nausea and vomiting 	<ul style="list-style-type: none"> ● Perform an appropriate assessment, including: vital signs, abdominal and pelvic examination and appropriate laboratory studies (pregnancy test, CBC, cultures) to rule out other problems, such as: endometritis, appendicitis, partial IUCD expulsion, uterine perforation, pregnancy/ectopic pregnancy or urinary tract infection. If appropriate, see section for management of pregnancy with the IUCD in place (page 51). ● Suspect PID if any of the following signs/symptoms are found and no other causes can be identified: <ul style="list-style-type: none"> ● Lower abdominal, uterine or adnexal tenderness (tenderness in the ovaries or fallopian tubes) ● Evidence of cervical infection: yellow cervical discharge containing mucus and pus, cervical bleeding when it is touched with a swab, positive swab test ● Tenderness or pain when moving the cervix and uterus during bimanual exam (cervical motion tenderness) ● Other possible sign/symptoms: purulent cervical discharge, enlargement or hardening (induration) of one or both fallopian tubes, a tender pelvic mass, pain when the abdomen is gently pressed (direct abdominal tenderness) or when gently pressed and then suddenly released (rebound abdominal tenderness) ● If endometritis or PID is suspected, begin treatment immediately with an appropriate antibiotic regimen per global standards/local protocols for gonorrhea, chlamydia and anaerobic infections. Remove the IUCD only in the presence of sepsis or if symptoms do not improve within 72 hours. Studies have not indicated that removing the IUCD affects outcomes of PID treatment.³⁴ <ul style="list-style-type: none"> ● If the woman does not want to keep the IUCD in during treatment, remove the IUCD 2 to 3 days after antibiotic treatment has begun. ● Where appropriate and when an STI is suspected, counsel the woman regarding condom use for protection against future STIs and recommend treatment for the partner.
--	--

<p>IUCD String Problems (Missing, Long, Short)</p>	<p>Missing Strings (Appendix I presents a job aid for managing missing strings.)</p> <ul style="list-style-type: none"> ● Ask the woman if she thinks the IUCD has fallen out. ● Rule out pregnancy by history or laboratory examination. ● Probe the cervical canal using an HLD or sterile cervical brush or narrow forceps (e.g., Bose, alligator) to locate the strings and gently draw them out so that they are protruding into the vaginal canal. ● If the strings are not located in the cervical canal, refer the woman for an X-ray or ultrasound to confirm normal intrauterine positioning. Provide a back-up method while waiting for results. Manage as appropriate based on findings: <ul style="list-style-type: none"> ● If the IUCD is located inside the uterus and the woman wants to keep the IUCD, do not remove it. Explain to her that the IUCD is still protecting her from pregnancy but that she will no longer be able to feel the strings. Review signs and symptoms of spontaneous expulsion. ● If the IUCD is located inside the uterus and the woman wants it removed, refer her for IUCD removal by a specially trained provider. ● If the IUCD cannot be visualized in the uterus or the peritoneal cavity, manage as complete IUCD expulsion (below). <p>Long Strings Trim strings, as needed, up to 3–4 cm from cervical os.</p> <p>Short Strings (if Bothersome to Woman or Partner)</p> <ul style="list-style-type: none"> ● Reassure the woman and her partner that the strings are very flexible and not harmful. ● If it is very bothersome, advise the woman that the IUCD strings can be cut shorter, so that the string curves around the cervical lip. Trim as needed.
---	--

<p>Partial or Complete IUCD Expulsion</p> <ul style="list-style-type: none"> ● New onset of irregular bleeding and/or cramping ● Expelled IUCD seen (complete expulsion) ● IUCD felt/seen in the vaginal canal (partial expulsion) ● Delayed or missed menstrual period (See Pregnancy with an IUCD in Place, below.) ● Missing or longer strings (See IUCD string problems, page 50.) 	<ul style="list-style-type: none"> ● Conduct an appropriate assessment, including: pelvic examination to rule out other possible causes of symptoms such as infection and pregnancy. ● When other possible causes of symptoms are ruled out, manage based on findings. <ul style="list-style-type: none"> ● If complete expulsion of the IUCD is confirmed (e.g., seen by the woman, confirmed by X-ray or ultrasound): replace IUCD immediately, if desired and appropriate (not pregnant or infected), or counsel for alternative family planning method. ● If partial IUCD expulsion is confirmed (e.g., felt/seen by the woman or clinician): remove the IUCD and replace it, if desired and appropriate (not pregnant or infected), or counsel for alternative family planning method. ● If the IUCD appears to be embedded in the cervical canal and cannot be easily removed in the standard fashion: refer the woman for IUCD removal by a specially trained provider. ● If complete expulsion of the IUCD is confirmed and pregnancy diagnosed, manage ANC per national and regional standards.
<p>Pregnancy with an IUCD in Place</p> <ul style="list-style-type: none"> ● Delayed or missed menstrual period ● Other signs/symptoms of pregnancy ● Missing strings ● Strings that are shorter or longer than expected 	<ul style="list-style-type: none"> ● Confirm pregnancy and trimester. If the woman is in her second or third trimester of pregnancy, manage according to global standards/local protocols and refer to an appropriate provider, if needed. ● Rule out ectopic pregnancy: sharp/stabbing abdominal pain (which is often unilateral), abnormal vaginal bleeding, light-headedness/dizziness, fainting. If ectopic pregnancy is suspected, immediately refer/transport the woman to a facility with surgical capability. ● When ectopic pregnancy has been ruled out, and if the pregnancy is in the first trimester: <ul style="list-style-type: none"> ● Counsel the woman on the benefits and risks of immediate removal of the IUCD. Removing the IUCD slightly increases the risk of miscarriage; leaving the IUCD in place can cause second trimester miscarriage, infection and preterm delivery. ● If the woman requests removal, proceed with immediate removal if the strings are visible and the pregnancy is in the first trimester. If the strings are not visible, do an ultrasound to determine whether the IUCD is still in the uterus or has been expelled. If the IUCD is still in place, it cannot be safely removed. Follow, as below, with plans to remove the IUCD at delivery. ● If the woman declines removal, provide support and care per standard global guidelines/local protocols and arrange close monitoring of the pregnancy by a qualified provider. Stress the importance of returning to the clinic immediately if she experiences signs of spontaneous abortion or infection (e.g., fever, low abdominal pain, and/or bleeding) or any other warning signs. Plan to remove the IUCD at delivery.

Case # _____
Date _____

Protocol for Management of Missing PPIUD Strings*

Situation: Use this protocol when you do not find the strings of the IUD protruding from the cervix on exam of a woman who has returned following postpartum placement of the IUD

Check action taken

1 2

3 4

5 6

7 8

9 10

11

12

13

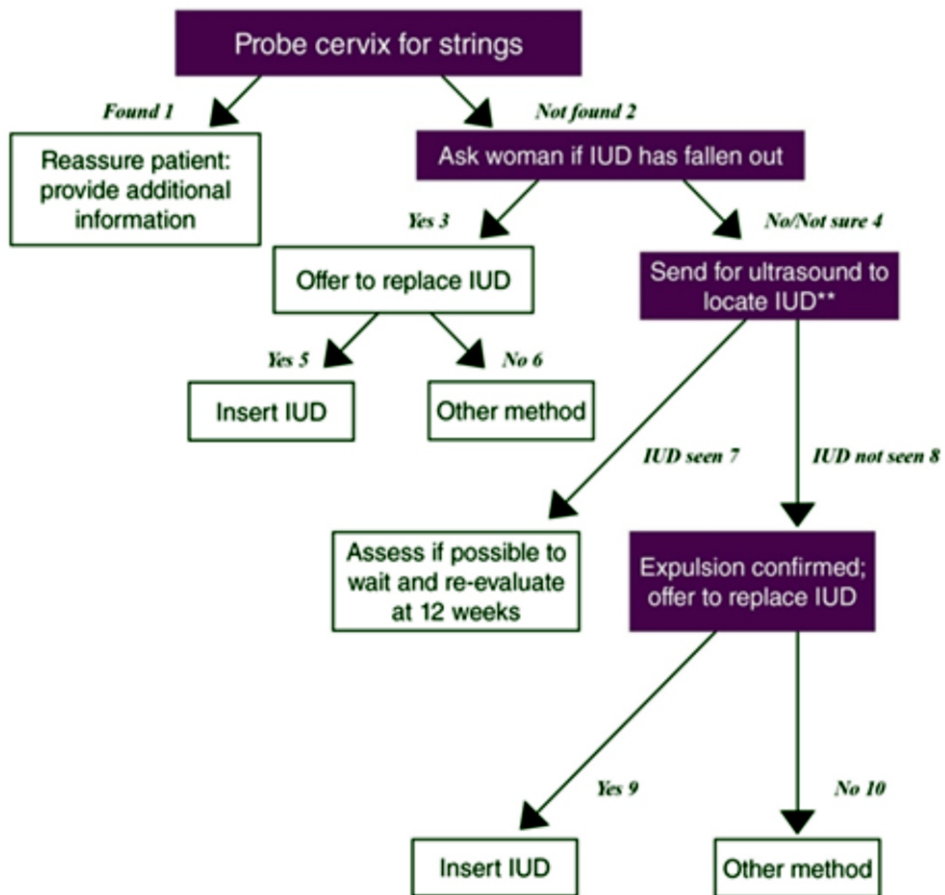

* If strings not seen at 3 months, repeat the protocol from start. If strings still not found, either:
 1. Reassure and follow-up 11
 2. Remove IUD with hook and replace 12
 ** Consider X-ray of abdomen instead of, or to augment, findings of ultrasound 13

Postpartum Implants

According to recommendation in MEC 2015 Contraceptive Implants have gained popularity in postpartum period. Contraceptive implants are small, flexible rods placed just under the skin of the upper arm. This package covers a number of contraceptive implant products, specifically Jadelle, Sino-implant (II), Implanon, and Implanon NXT. As of March 2014, only Jadelle, Implanon, and Implanon NXT have received WHO pre-qualification, a distinction that guides international procurement agencies and countries for bulk purchasing.

All contraceptive implants are highly effective and provide long-term pregnancy protection: for the two-rod implants, Jadelle provides 5 years of protection and Sino-implant (II) provides 4 years; the one-rod implants provide 3 years of protection. Implants can be removed by a trained provider at any time, with no delay in the return to fertility. Neither two-rod nor one-rod implants contain estrogen, and both types are therefore a viable option for breastfeeding women or others who cannot use methods that contain estrogen.

They are suitable for breastfeeding and non-breastfeeding postpartum women (starting immediately after childbirth and anytime onwards), and are also a viable method for post-abortion clients, adolescents, and youth.

Female sterilization

Postpartum tubal ligation may be performed with proper counseling and consent in breastfeeding and non-breastfeeding women:

- Immediately after childbirth
- During cesarean section
- Within 7 days postpartum
- Six weeks or more after childbirth
- Within 48 hours after uncomplicated abortion

Female sterilization should be considered permanent and irreversible. Ideally, counseling for postpartum female sterilization should be provided as a routine part of antenatal care. Antenatal FP counseling will give the client time to reflect and weigh her options so that she is fully prepared to have the procedure immediately postpartum.

Condoms

- The couple should be advised to abstain from sexual intercourse until any vaginal or perineal lacerations have completely healed and the mother feels rested and ready. Condoms can then be used by both breastfeeding and non-breastfeeding mothers use of other barrier methods, such as diaphragms or cervical caps, should be delayed for at least 6 weeks postpartum.

Hormonal Contraception

Progestin-only Pills, injectables, and implants

- Non-breastfeeding mothers may start any progestin-only method immediately/at any time after delivery.
- For breastfeeding mothers, progestin-only injectables methods are not introduced until at least 6 weeks postpartum, once breastfeeding is well-established and the milk supply is adequate.
- When used consistently and correctly, progestin-only methods add to the contraceptive effect of breastfeeding and are 99 percent effective at preventing pregnancy in breastfeeding mothers.
- Irregular vaginal bleeding in the form of spotting is the most common side effect associated with progestin-only methods and does not indicate contraceptive failure.
- Progestin-only methods can be given to women immediately after abortion or miscarriage at their request.

Progestin-Only Pills (POPs)

- Breastfeeding women may start POPs at less than 6 weeks postpartum.

Progestin-Only Injectables (PICs)

- Breastfeeding women may start injections at or after 6 weeks postpartum.
- Women at high risk of getting pregnant before 6 weeks postpartum and who request PICs should be advised to delay the first injection until breastfeeding is fully established, usually by day 21 postpartum.

Progestin-Only Implants

- Breastfeeding women may have levonorgestrel (LNG) and etonogestrel (ETG) implants and Sino implant(II) inserted at less than 6 weeks postpartum.

Combined Hormonal Contraception (oestrogen and Progestin): injectables, pills

- Non-breastfeeding mothers may start combined hormonal contraception as early as 3 weeks postpartum.
- Breastfeeding mothers should delay initiation of combined hormonal contraceptive methods until at least 6 months postpartum. Oestrogen may decrease breast milk production but has not been shown to be harmful to the breastfeeding infant in any other way.
- Breastfeeding women should be advised that combined hormonal methods can be used without restriction from 6 months postpartum.
- If breastfeeding is established and other contraceptive methods are contra- indicated, combined hormonal methods may be considered.
- Combined hormonal contraceptive methods can be given to women immediately after first- or second-trimester miscarriage or abortion.
- Emergency contraceptive pills may be used as early as 4 weeks after childbirth regardless of breastfeeding status.

Topic	MEC Recommendation
1. Recommendations for CHC use among breastfeeding women	
< 6 weeks postpartum	Breastfeeding women < 6 weeks postpartum should not use CHCs (MEC Category 4).
= 6 weeks to <6 months postpartum	Breastfeeding women = 6 weeks to < 6 months postpartum (primarily breastfeeding) generally should not use CHCs (MEC Category 3).
= 6 months postpartum	Breastfeeding women = 6 months postpartum can generally use CHCs (MEC Category 2).
2. Recommendations for CHC use among postpartum women	
< 21 days postpartum without other risk factors for venous thromboembolism (VTE)	Women who are < 21 days postpartum and do not have other risk factors for VTE generally should not use CHCs (MEC Category 3).
< 21 days postpartum with other risk factors for VTE	Women who are < 21 days postpartum with other risk factors for VTE should not use CHCs (MEC Category 4).
= 21 days to 42 days postpartum without other risk factors for VTE	Women who are = 21 days to 42 days postpartum without other risk factors for VTE can generally use CHCs (MEC Category 2).
= 21 days to 42 days postpartum with other risk factors for VTE	Women who are = 21 days to 42 days postpartum with other risk factors for VTE generally should not use CHCs (MEC Category 3).
> 42 days postpartum	Women who are > 42 days postpartum can use CHCs without restriction (MEC Category 1).
3. Recommendations for progestogen-only contraceptive (POC) and levonorgestrel-releasing intrauterine device (LNG-IUD) use among breastfeeding women	
3a. POC use among breastfeeding women (POCs include progestogen-only pills, implants and injectables)	
< 6 weeks postpartum	Breastfeeding women who are < 6 weeks postpartum can generally use progestogen-only pills (POPs) and levonorgestrel (LNG) and etonogestrel (ETG) implants (MEC Category 2). Breastfeeding women who are < 6 weeks postpartum generally should not use progestogen-only injectables (POIs) (DMPA or NET-EN) (MEC Category 3). Range: Low to very low
= 6 weeks to < 6 months postpartum	Breastfeeding women who are = 6 weeks to < 6 months postpartum can use POPs, POIs, and LNG and ETG implants without restriction (MEC Category 1).
= 6 months postpartum	Breastfeeding women who are = 6 months postpartum can use POPs, POIs, and LNG and ETG implants without restriction (MEC Category 1).
3b. LNG-IUD use among breastfeeding women	
< 48 hours postpartum	Breastfeeding women who are < 48 hours postpartum can generally use LNG-IUDs (MEC Category 2).
= 48 hours to < 4 weeks postpartum	Breastfeeding women who are = 48 hours to < 4 weeks postpartum generally should not have an LNG-IUD inserted (MEC Category 3).
= 4 weeks postpartum	Breastfeeding women who are = 4 weeks postpartum can use an LNG-IUD without restriction (MEC Category 1).
Puerperal sepsis	Breastfeeding (and non-breastfeeding) women with puerperal sepsis should not have an LNG-IUD inserted (MEC Category 4).

Integration of Postpartum Family Planning services:

Missed opportunities

Postpartum FP can be offered during:

- **Antenatal care:** Women should be counselled about important options prior to birth if they are to make a good decision concerning PFP, especially regarding methods that are provided during the immediate postpartum period.
- **Childbirth care:** FP counselling and method provision should be systematically offered as a part of the full scope of childbirth services. In Pakistan, 57percent of women who had received FP counselling and leaflets prior to discharge from the maternity unit had started using a modern contraceptive method by 8-12 weeks postpartum. However, only 6 percent of women who did not receive this information prior to discharge were using a contraceptive by 8-12 weeks postpartum.
- **Postpartum care:** FP counselling and method provision should be systematically offered at every postpartum visit as a routine part of the full scope of postpartum/postnatal services.
- **Well baby/well child care, including immunization clinics:** The only contact a woman may have with the health care system after birth may be the care she obtains for her baby and other children. Well baby/well child care clinics offer an important opportunity for reinforcing LAM and responding to women with an unmet need for FP.
- **Sick baby care:** The illness of a baby may be the only time a woman encounters a health care provider.
- **PMTCT care:** HIV-positive women may want to space or limit pregnancies. Pregnancy spacing is especially important for HIV-positive women on antiretroviral therapy. FP services should be routinely offered wherever PMTCT services are available.
- **Family planning and reproductive health care:** A woman may seek FP services at any time after her baby is born.
- **Postabortion care:** FP counselling and method provision should be offered routinely before and after procedures and during treatment for complications.

Studies have shown that FP counselling is most effective when provided at more than one point during a woman's pregnancy and childbirth cycle. PFP should be a routine part of maternal, newborn, and child health care across the continuum of a woman's childbearing cycle.

16

RTIs/STIs, HIV CLINICAL DISEASE 1,2 (MILD) 3,4 (SEVERE), AND HEPATITIS

Introduction

This chapter deals with minimizing the risk of spreading reproductive tract infections (RTIs), sexually transmitted infections (STIs), HIV Clinical disease 1,2 (Mild) 3,4 (Severe), and hepatitis B. To minimize this risk and care for clients effectively, the health care provider should be knowledgeable about these diseases and their management.

Health care providers can play a pivotal role in preventing the spread of RTIs/ STIs, HIV/ (Clinical disease 1,2 (Mild) 3,4 (Severe)), and hepatitis, and treating clients suffering from these infections. It is therefore important that they be able to identify these cases, give advice on preventive measures, and suggest how they can be managed.

Reproductive Tract Infections

Reproductive tract infections are a group of infections affecting the reproductive system and can lead to diseases affecting the reproductive tract (e.g., pelvic inflammatory disease) that have both immediate (e.g., tubo-ovarian abscess) and long-term (e.g., infertility) consequences. They include STIs, non-sexually transmitted infections like endogenous infections caused by the overgrowth of the organisms normally present in the reproductive tract, and iatrogenic infections caused by medical procedures when infection control is poor.

Sexually Transmitted Infections

STIs are infections that are spread from one person to another by sexual contact, and can lead to sexually transmitted diseases with both acute and long-term consequences.

Policy

After incorporating the recommendation of the ICPD (International Conference on Population Development, Cairo, 1994), in the ninth Five Year Plan, a package of comprehensive Reproductive Health Services was prepared to be offered in the service outlets of all health and population welfare programmes as well as private facilities. Facilities for screening and managing RTIs/STIs will be made available to all clients and preventive health education will be offered.

Standards

- Clients requiring RTI/STI information and treatment will be provided comprehensive counselling, treatment, and referral, if required.
- All health and family planning (FP) facilities should have information, education, and communication (IEC) materials available along with preventive and curative facilities for the common RTIs/STIs.
- No client will be denied of treatment on the basis of his/her HIV status.

Classification of RTIs/STIs

Several types of organisms cause STIs. Those caused by organisms such as bacteria generally can be successfully treated with the correct antibiotic regimen. STIs caused by viruses are not responsive to antibiotics but can be prevented in some cases through vaccination (e.g., hepatitis B) or their symptoms can be relieved by medications.

Table 16-1. Classification of Reproductive Tract and Sexually Transmitted Infections

Sexually Transmitted Infection	Type	Organism	Sexual Transmission	Non-Sexual Transmission	Treatable
Chancroid	Bacterial	Haemophilus ducreyi	Vaginal, anal, and oral sex	None	Yes
Chlamydia	Bacterial	Chlamydia trachomatis	Vaginal and anal sex, rarely from genitals to mouth	From mother to child during delivery	Yes
Gonorrhoea	Bacterial	Neisseria gonorrhoea	Vaginal and anal sex, or contact between mouth and genitals	From mother to child during delivery	Yes
Hepatitis B	Viral	HBV	Vaginal and anal sex, or from penis to mouth	In blood, from mother to child during delivery or in breast milk	No*

Sexually Transmitted Infection	Type	Organism	Sexual Transmission	Non-Sexual Transmission	Treatable
Herpes	Viral	Herpes simplex virus type-II	Genital or oral contact with an ulcer, including vaginal and anal sex; also genital contact in area without ulcer	From mother to child during pregnancy or delivery	No
HIV	Viral	Human immunodeficiency virus	Vaginal and anal sex, very rarely oral sex	In blood, from mother to child during pregnancy or delivery or in breast milk	No
Genital warts	Viral	Human papillomavirus (HPV)	Skin-to-skin and genital contact or contact between mouth and genitals	From mother to child during delivery	Yes**
Syphilis	Bacterial	Treponema pallidum	Genital or oral contact with an ulcer, including vaginal and anal sex	From mother to child during pregnancy or delivery	Yes
Trichomoniasis	Parasite	Trichomonas vaginalis	Vaginal, anal, and oral sex	From mother to child during delivery	Yes
Candidiasis	Fungal	Candida albicans	Vaginal, anal, and oral sex	No	Yes
Bacterial vaginosis	Bacterial	Mycoplasma hominis	Vaginal, anal, and oral sex	No	Yes
Granuloma inguinale	Bacterial	C. granulomatis	Vaginal, anal, and oral sex	No	Yes
Lymphogranuloma venereum (LGV)	Bacterial	C. trachomatis	Vaginal, anal, and oral sex	No	Yes

* Can be prevented by vaccination.

** Some of the manifestations of genital warts can be treated by medical or surgical means.

Strategies for Control

Strategies for RTI/STI control as recommended by the World Health Organization (WHO) are as follows:

- **Strategy 1: Use male or female condom correctly with every act of sex:**
 - One method that helps protect against pregnancy and STIs, including HIV.
- **Strategy 2: Use condoms consistently and correctly, plus another FP method:**
 - Adds extra protection from pregnancy in case a condom is not used or is used incorrectly.
 - May be a good choice for women who want to be sure to avoid pregnancy but cannot always count on their partners to use condoms.
- **Strategy 3: If both partners know they are not infected, use any FP method to prevent pregnancy and stay in a mutually faithful relationship:**
 - Many FP clients will fall into this group and thus are protected from STIs, including HIV.
 - Depends on communication and trust between partners.

Role of the Health Care Provider

STIs are common, and cause much suffering and disability. All health care providers have a responsibility to do what they can to prevent and treat STIs. The providers should recognize signs of STIs and either promptly treat or refer for treatment.

Women who currently have an STI indicative of gonococcal or chlamydial origin are likely to be at higher risks for these infections and should not use IUCDs.

Providers should diagnose and treat STIs before inserting an IUCD. During the treatment period, the couple should be provided with an option to use alternative contraceptive methods.

Men and women who have several sex partners have more chances of getting STIs. Sex workers and the clients of sex workers are most likely to get STIs. Female sex workers also usually want to avoid pregnancy, so they may come to health care providers for contraceptives.

Protocol for Treatment

- History taking
- Examination
- Counselling
- Management and follow-up

History Taking

During history taking and examination for RTIs/STIs, it is important to win the client's trust to obtain all necessary information. The session should be conducted in privacy and in a non-judgemental manner. Four sets of information are needed:

- General history
- Medical history
- Present illness
- Sexual history

The Five Ps of Sexual History:

1. Partner (Spouse)
2. Prevention of pregnancy
3. Protection from RTIs/STIs
4. Practices
5. Past history of RTIs/STIs

1. Partner (Spouse)

When assessing sexual risk, it is important to determine the number of sexual contacts a client has had. If the client has had multiple contacts, there is a need to explore for specific risk factors such as other contacts, injecting drug use, history of STIs, and drug use with sex. If the client has no partner other than her/his spouse, the health care provider should ask about the length of the relationship and the spouse's risk, such as other contacts and injecting drug use.

2. Prevention of pregnancy

Based on the information about a male partner (see above), the health care provider can determine if the spouse is at risk of becoming pregnant. If this is the case, the health care provider should determine if the pregnancy is desired.

3. Protection from RTIs/STIs

Through discussion, the health care provider should explore different issues such as condom use, monogamy/polygamy, client self-perception of risk, and perception of spouse's risk.

4. Practices

If the client has had more than one partner in the past year, the health care provider may want to further explore the client's sexual practices and condom usage. Asking about other sex practices will guide risk reduction strategies and help in identifying anatomical sites from which to collect specimens for STIs testing.

5. Past history of RTIs/STIs

A history of gonorrhoea or chlamydia increases a person's risk of repeated infection. STIs in the recent past indicate higher risk behaviour.

Examination

It includes skin examination as well as pelvic examination in females; examination of vulva, anus, and perineum; and palpation of the inguinal region for enlarged lymph nodes. In

males, the genital, inguinal, and perianal regions are examined.

Counselling

People who seek treatment for a suspected STI constitute a very important target group for education and counselling for prevention of RTIs/STIs. Those who are actually diagnosed with an RTI/STI may be more receptive to advice. They now have proof that "it can happen to me", not only to others. This is a valuable opportunity to communicate with them about the risk of HIV/ (Clinical disease 1,2 (Mild) 3,4 (Severe)), infection and how to avoid future RTIs/STIs.

Preventing STIs

People can avoid STIs by changing their sexual behaviour. They can follow any of the ABCD: Abstain, Be mutually faithful, Consistently Use Condoms (and Do not share needles).

Abstain from sex.

Or

Be mutually faithful.

Or

Consistently use condoms.

And

Do not share needles/blades/razors.

The Four Basic Health Education Messages

In syndromic management of RTIs/STIs, the following messages are a must in counselling the patients and/or their partner(s):

- Comply with treatment.
- Practice safe sex behaviour.
- Use condoms for prevention of both pregnancy and STIs.
- Manage partner.

There is no standard order in which these messages should be delivered. However, patients tend to be most responsive to messages related to their own cure, followed by the treatment of those close to them, for instance a spouse. There is often a lack of interest in discussing the long-term consequences of STIs, especially the risk of acquiring or transmitting HIV and the behavioural changes required for preventing its spread.

WELL Method

Good RTI/STI counselling should include the "WELL" method of communication to make RTI/STI clients comfortable and let them know that we want to help them.

W= Welcome the Clients

Greet the clients warmly and offer them a seat. Sit close enough to them so that they can talk comfortably and privately. Have a welcoming tone in the voice.

E= Encourage the Clients to Talk

Encourage clients to talk by looking at them as they speak, by asking questions, by nodding as they speak, by saying "Mmm, Hmmm" or "Tell me more about that", etc.

L= Look at the Clients

Looking at the clients as they speak helps them to talk comfortably. Make sure the provider has a warm and friendly facial expression.

L= Listen to the Clients

Listen carefully to what the clients have to say.

In counselling someone who thinks that she/he may have an STI, tell the person to do the following:

- Get diagnosed and treated immediately. Many STIs can be treated and cured, especially in their early stages. Some, such as HIV and herpes, cannot be cured, but sometimes their effects can be stopped for a time.
- Take all of the medicine according to the instructions, even if symptoms go away. Inform the client that the medicines can cause some side effects such as vomiting, diarrhoea, or a rash. If any of these side effects occur and are severe, the person must return to the clinic that provided the medicine.
- Avoid sex with anyone until 3 days after treatment is finished and all symptoms are gone to prevent spread.
- Get treatment for his/her spouse also so that both can get treated. Unless all sex partners are treated at the same time, they will infect each other again and again. It is especially important that a man informs his female partner.
- This is because many women do not have symptoms until the STI has reached a more serious stage.
- Pregnant woman should visit an antenatal clinic within the first 3 months of pregnancy for a physical exam and syphilis test to protect the unborn child.

Management: The Syndromic Approach

Ideally, each case of RTI/STI should be properly diagnosed and appropriate treatment should be given according to the diagnosis. But this may not be possible in most of the areas of the world. WHO endorses simple and effective regimes and tools to be used in the situations where standard laboratory tests to identify RTIs/STIs are expensive and require equipment that is generally unavailable to clinics in those areas or countries.

The primary screening approach developed, syndromic management, diagnoses infection based on the presence of symptoms of the disease rather than on laboratory tests. A syndrome is a collection or group of symptoms that the patient complains of; the health care provider observes the signs of these symptoms when examining the patient. Depending on the signs, the health care provider may manage the patient by using a simple flowchart or algorithm. This management approach is acceptable, feasible, and cost-effective in most settings.

Following are flowcharts for the management of the symptoms of RTIs/STIs, based on the "syndromic approach".

Figure 16 1. Flowchart for Syndromic Management of Urethral Discharge

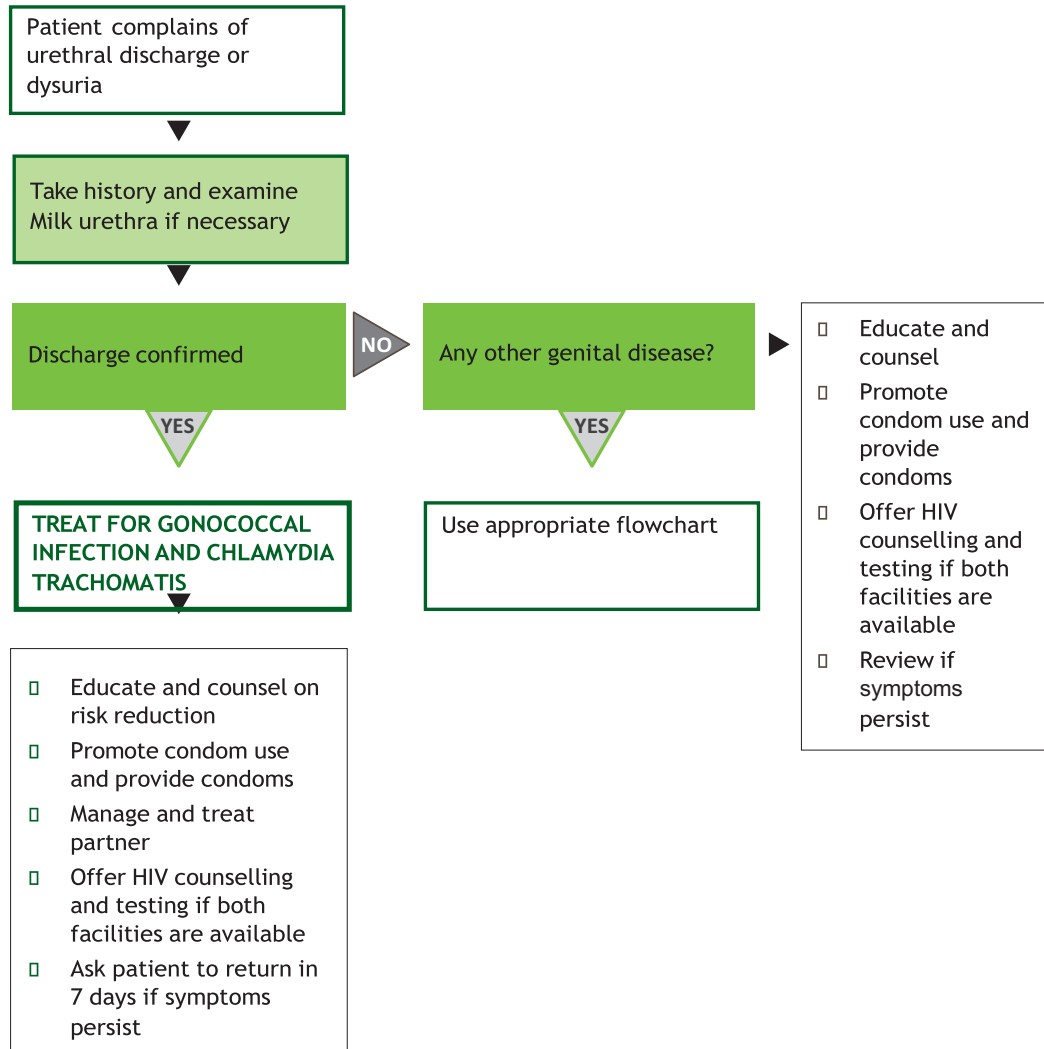

Treatment Options for Urethral Discharge

Treatment Options for Gonorrhoea

- Ciprofloxacin, 500 mg orally, as a single dose
- OR
- Ceftriaxone, 125 mg by intramuscular injection, as a single dose
- OR
- Cefixime, 400 mg orally, as a single dose
- OR
- Spectinomycin, 2 g by intramuscular injection, as a single dose

Note:

- Ciprofloxacin is contraindicated in pregnancy, and is not recommended for use in children and adolescents.
- There are variations in the anti-gonococcal activity of individual quinolones, and it is important to use only the most active.

Treatment Options for Chlamydia

- Doxycycline, 100 mg orally, twice daily for 7 days
OR
- Azithromycin, 1 g orally, in a single dose

Alternative Regimen

- Amoxicillin, 500 mg orally, three times a day for 7 days
OR
- Erythromycin, 500 mg orally, four times a day for 7 days
OR
- Ofloxacin, 300 mg orally, twice a day for 7 days
OR
- Tetracycline, 500 mg orally, four times a day for 7 days

Note:

- Doxycycline and other tetracyclines are contraindicated during pregnancy and lactation.
- Current evidence indicates that 1 g single-dose therapy of Azithromycin is efficacious for chlamydial infection.
- There is evidence that extending the duration of treatment beyond 7 days does not improve the cure rate in uncomplicated chlamydial infection.
- Erythromycin should not be taken on an empty stomach.

Note:

- WHO recommends that, where possible, single-dose therapy be used.

The Syndromic Management of Vaginal Discharge

Figure 16-2. Flowchart for Syndromic Management of Vaginal Discharge

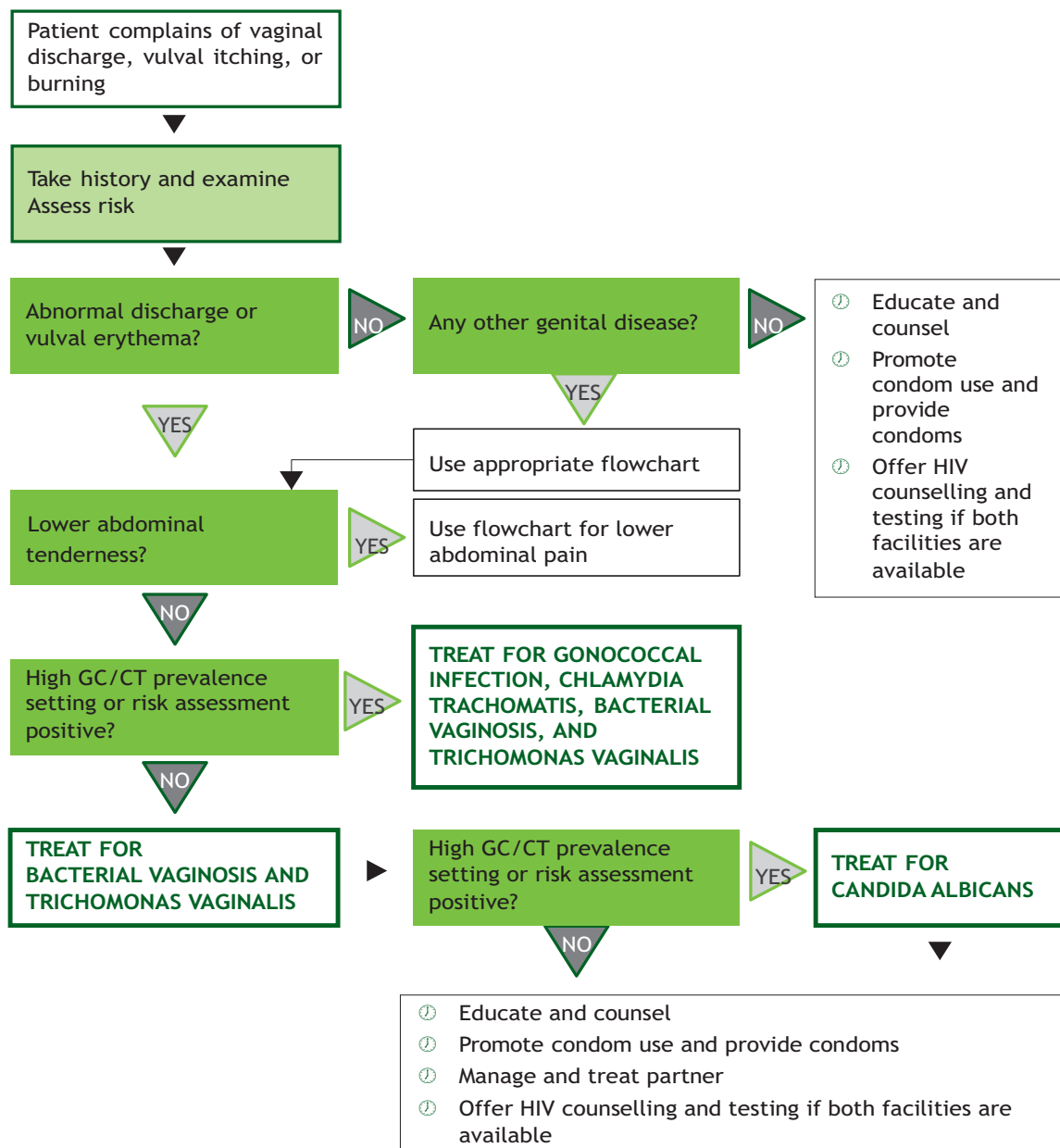

Treatment Options for Vaginal Discharge

Treatment Options for Cervical Infection

- Therapy for uncomplicated gonorrhoea (refer to urethral discharge)
PLUS
- Therapy for chlamydia (refer to urethral discharge)

Treatment Options for Vaginal Infection, Trichomoniasis

- Metronidazole, 2 g orally, in a single dose
OR
- Tinidazole, 2 g orally, in a single dose

Note:

- The reported cure rate in women ranges from 82-88 percent, but may be increased to 95 percent if sexual partners are treated simultaneously.

Alternative Regimen

- Metronidazole, 400 mg or 500 mg orally, twice daily for 7 days
OR
- Tinidazole, 500 mg orally, twice daily for 5 days

Note:

- Other 5-nitroimidazoles are also effective, both in single- and in multiple-dose regimens.
- Patients taking metronidazole or other imidazoles should be cautioned not to consume alcohol while they are taking the drug, and for up to 24 hours after taking the last dose.
- Metronidazole is generally not recommended for use in the first trimester of pregnancy.
- Asymptomatic women with trichomoniasis should be treated with the same regimen as symptomatic women.

Treatment Options for Bacterial Vaginosis

- Metronidazole, 400 mg or 500 mg orally, twice daily for 7 days

Alternative Regimen

- Metronidazole, 2 g orally, as a single dose
OR
- Clindamycin 2 percent vaginal cream, intravaginally, at bedtime for 7 days

Pregnant Women

- Metronidazole, 200 or 250 mg orally, three times daily for 7 days, after first trimester
- Metronidazole 2 g orally, as a single dose, if treatment is imperative during the first trimester of pregnancy

Candidiasis

- Miconazole or Clotrimazole, 200 mg intravaginally, daily for 3 days
OR
- Clotrimazole, 500 mg intravaginally, as a single dose
OR
- Fluconazole, 150 mg orally, as a single dose

Alternative Regimen

- Nystatin, 100,000 IU intravaginally, daily for 14 days

The Syndromic Management of Genital Ulcers

Figure 16-3. Flowchart for Syndromic Management of Genital Ulcers

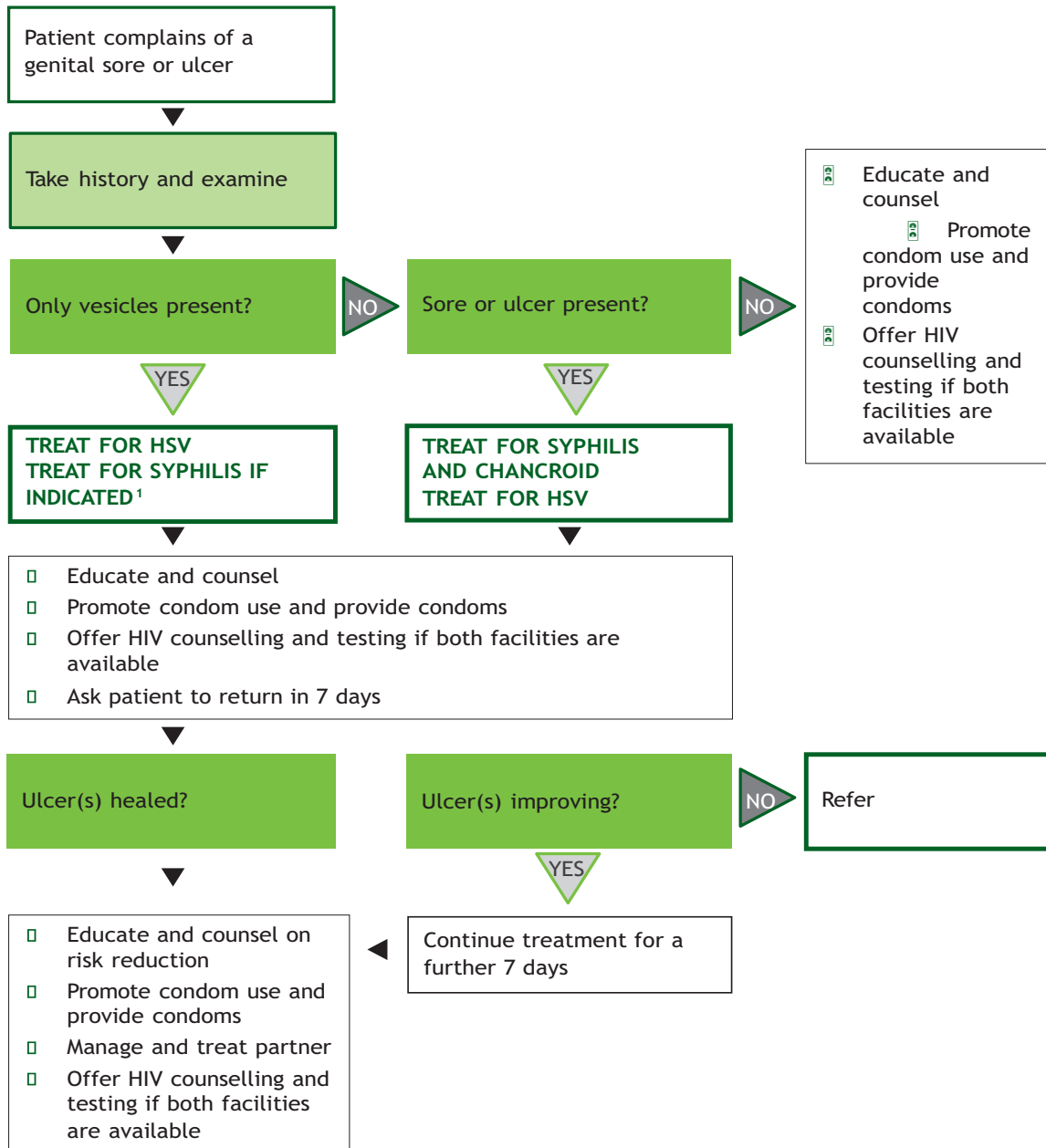

1. Indications for syphilis treatment:
 - RPR-positive; and
 - Patient has not been treated for syphilis recently.
2. Treat for HSV where prevalence is 30 percent or higher, or adapt to local conditions.

Treatment Options for Genital Ulcers

Treatment Options for Syphilis

- Benzathine benzylpenicillin¹ 2.4 million IU by intramuscular injection, at a single session. Because of the volume involved, this dose is usually given as two injections at separate sites.

Alternative Regimen

- Procaine benzylpenicillin² 1.2 million IU by intramuscular injection, daily for 10 consecutive days

Alternative Regimen for Penicillin-allergic, Non-pregnant Patients

- Doxycycline, 100 mg orally, twice daily for 14 days
- OR**
- Tetracycline, 500 mg orally, four times daily for 14 days

Alternative Regimen for Penicillin-allergic, Pregnant Patients

- Erythromycin, 500 mg orally, four times daily for 14 days

Treatment Options for Chancroid

- Ciprofloxacin, 500 mg orally, twice daily for 3 days
- OR**
- Erythromycin base, 500 mg orally, four times daily for 7 days
- OR**
- Azithromycin, 1 g orally, as a single dose

Alternative Regimen

- Ceftriaxone, 250 mg by intramuscular injection, as a single dose

Treatment Options for Granuloma Inguinale

- Azithromycin, 1 g orally on first day, then 500 mg orally, once a day
- OR**
- Doxycycline, 100 mg orally, twice daily

Alternative Regimen

- Erythromycin, 500 mg orally, four times daily
- OR**
- Tetracycline, 500 mg orally, four times daily
- OR**
- Trimethoprim 80 mg/sulfamethoxazole 400 mg, two tablets orally, twice daily for a minimum of 14 days

1 Benzathine benzylpenicillin synonyms: Benzathine penicillin G; benzylpenicillin Benzathine; Benzathine penicillin.

2 Procaine benzylpenicillin synonyms: procaine penicillin G.

Note:

- Treatment should be continued until all lesions are epithelialized.

Treatment Options for Lymphogranuloma Venereum (LGV)

- Doxycycline, 100 mg orally, twice daily for 14 days
- OR**
- Erythromycin, 500 mg orally, four times daily for 14 days

Alternative Regimen

- Tetracycline, 500 mg orally, four times daily for 14 days

Note:

- Tetracyclines are contraindicated in pregnancy.
- Fluctuant lymph nodes should be aspirated through healthy skin. Incision and drainage or excision of nodes may delay healing. Some patients with advanced disease may require treatment for longer than 14 days, and sequelae such as strictures and/or fistulae may require surgery.

Treatment Options for Genital Herpes

- Acyclovir, 200 mg orally, five times daily for 7 days
- OR**
- Acyclovir, 400 mg orally, three times daily for 7 days
- OR**
- Valaciclovir, 1 g orally, twice daily for 7 days
- OR**
- Famciclovir, 250 mg orally, three times daily for 7 days

Note:

- The decision to treat for chancroid, granuloma inguinale, or LGV depends on the local epidemiology of the infections.
- Specific treatment for herpes genitalis is recommended as it offers clinical benefits to most symptomatic patients. Health education and counselling regarding the recurrent nature of genital herpes lesions, the natural history, sexual transmission, probable perinatal transmission of the infection, and available methods to reduce transmission are an integral part of genital herpes management.

The Syndromic Management of Lower Abdominal Pain

Figure 16-4. Flowchart for Syndromic Management of Lower Abdominal Pain

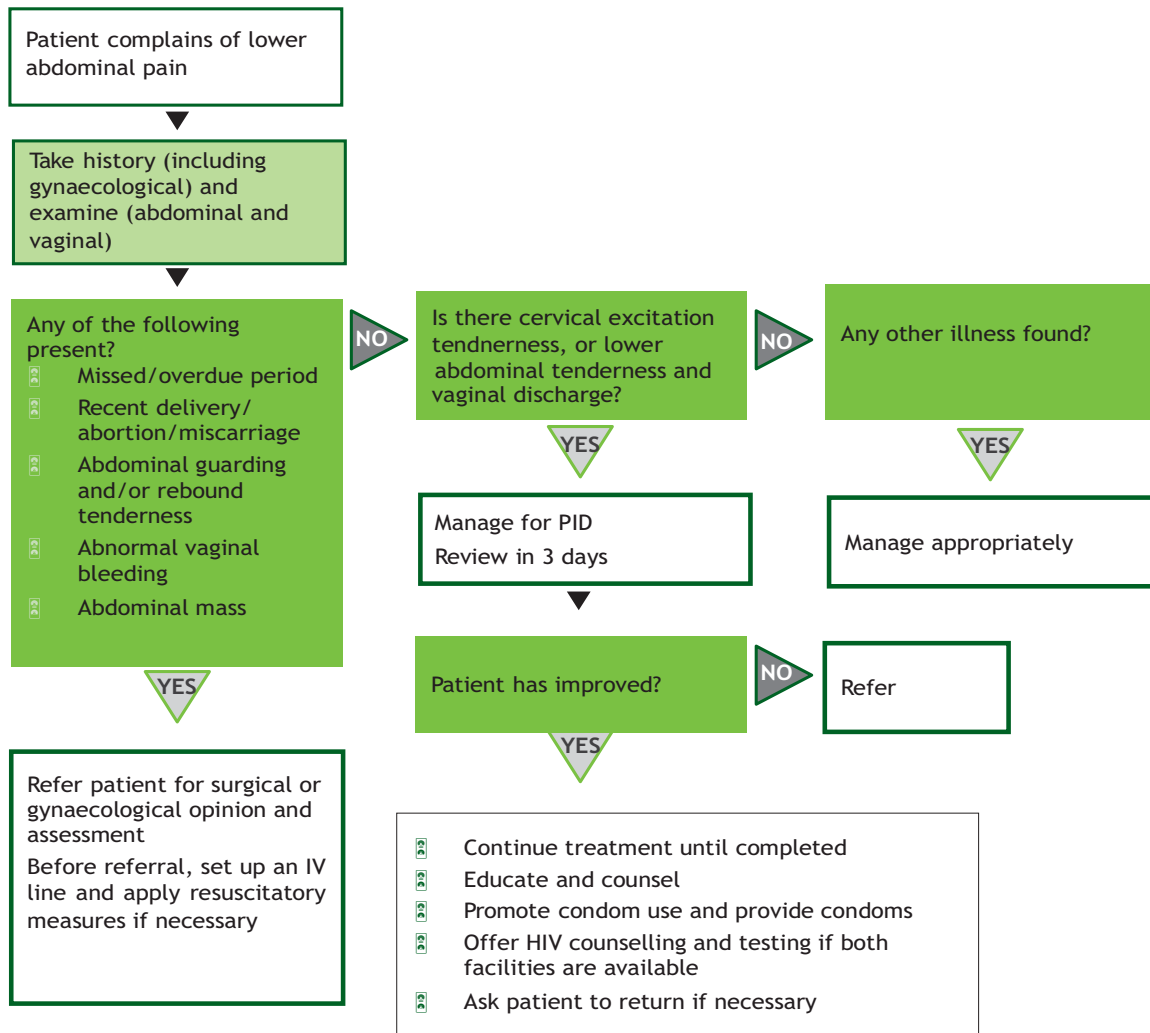

Treatment Options for Lower Abdominal Pain

Recommended Syndromic Treatment

- Single-dose therapy for uncomplicated gonorrhoea
PLUS
- Doxycycline, 100 mg orally, twice daily, or tetracycline, 500 mg orally, four times daily for 14 days
PLUS
- Metronidazole, 400–500 mg orally, twice daily for 14 days

Note:

- Patients taking Metronidazole should be cautioned to avoid alcohol.
- Tetracyclines are contraindicated in pregnancy.

The Syndromic Management of Scrotal Swelling

Figure 16-5. Flowchart for Syndromic Management of Scrotal Swelling

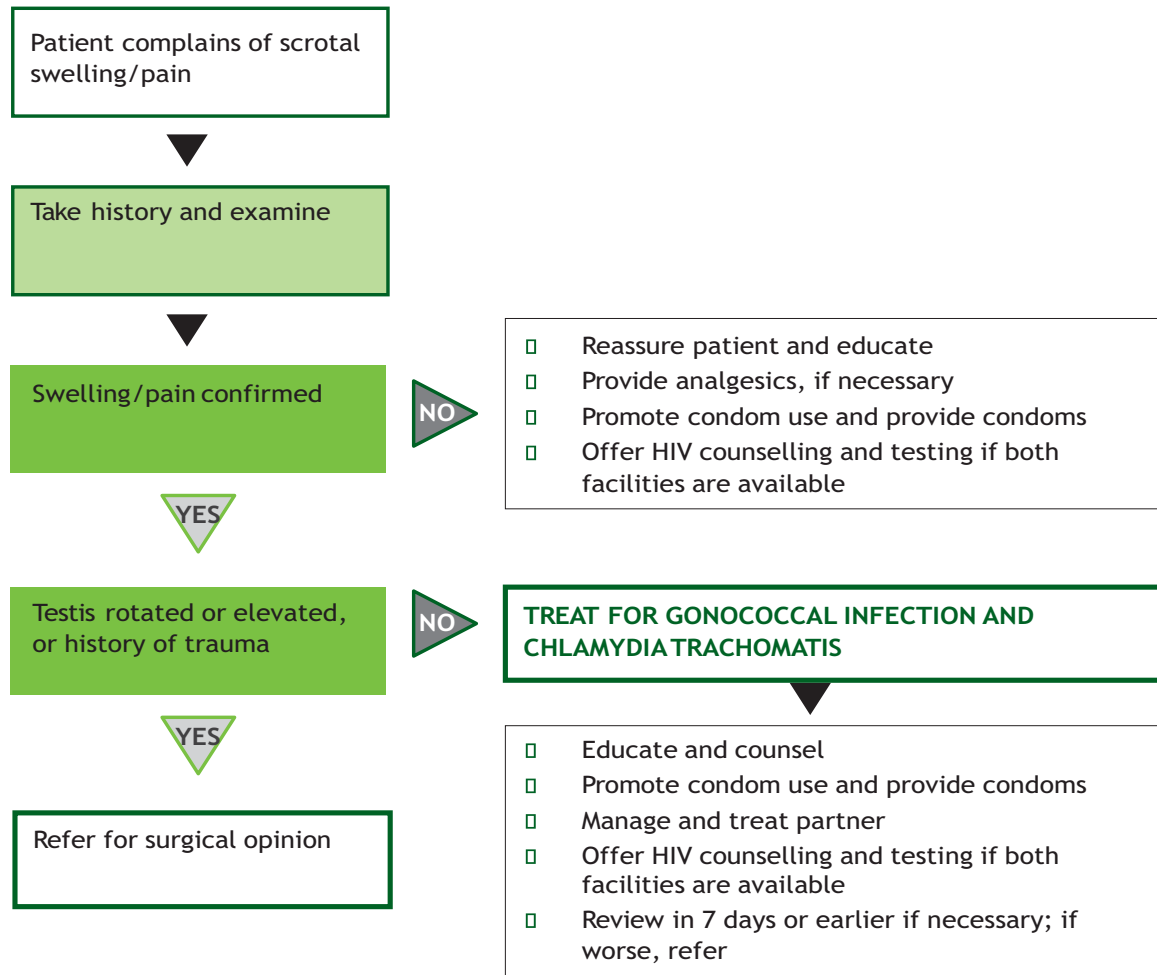

Treatment Options for Scrotal Swelling

Recommended Syndromic Treatment

- Therapy for uncomplicated gonorrhoea (refer to urethral discharge)
PLUS
- Therapy for chlamydia (refer to urethral discharge)

The Syndromic Management of Inguinal Bubo

Figure 16-6. Flowchart for Syndromic Management of Inguinal Bubo

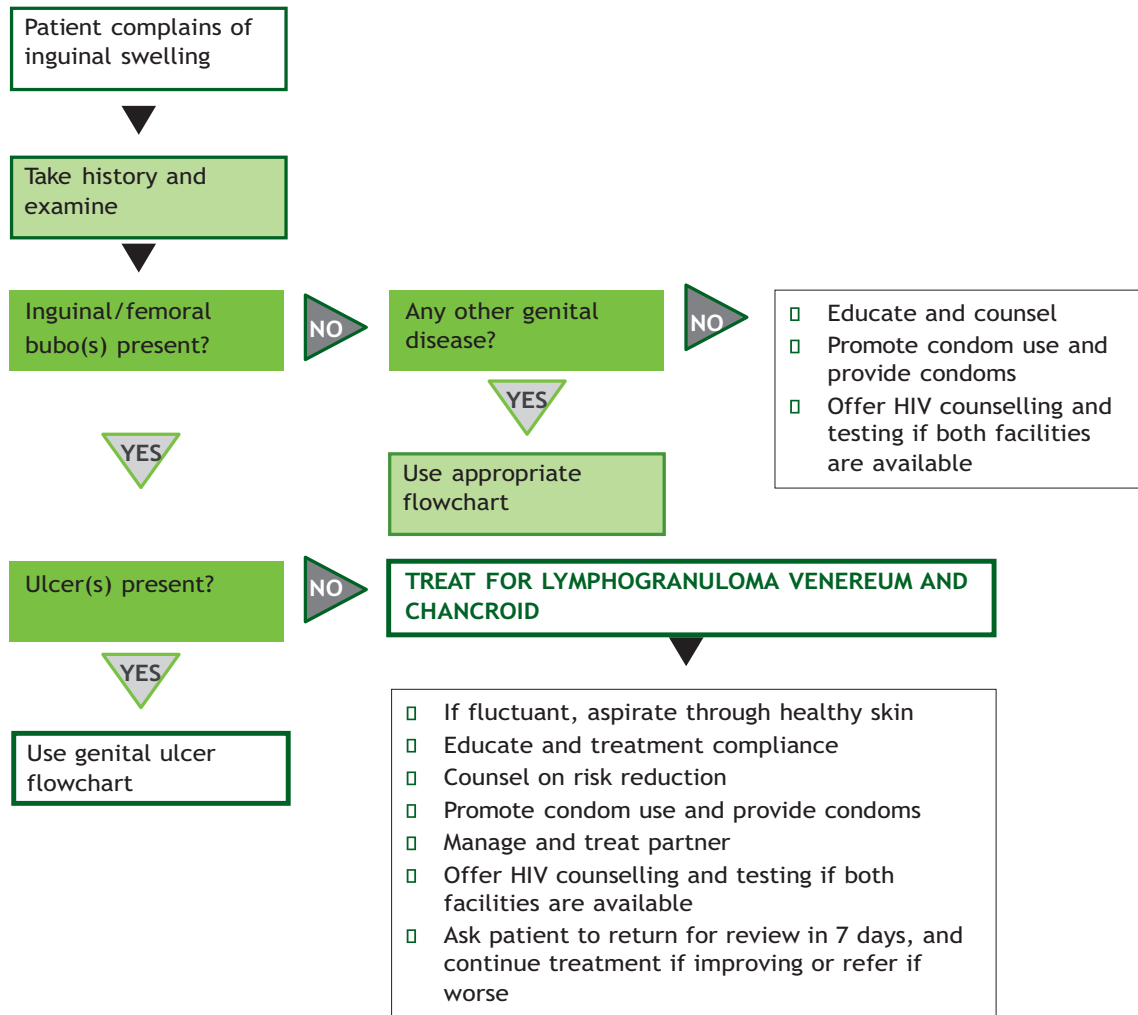

Treatment Options for Inguinal Bubo

Recommended Syndromic Treatment

- Ciprofloxacin; 500 mg orally, twice daily for 3 days
- AND**
- Doxycycline, 100 mg orally, twice daily for 14 days
- OR**
- Erythromycin, 500 mg orally, four times daily for 14 days

Note:

- Some cases may require longer treatment than the 14 days recommended above. Fluctuant lymph nodes should be aspirated through healthy skin. Incision and drainage or excision of nodes may delay healing and should not be attempted. Where there is doubt and/or treatment failure, referral for diagnostic biopsy is advisable.

The Syndromic Management of Neonatal Conjunctivitis

Figure 16-7. Flowchart for Syndromic Management of Neonatal Conjunctivitis

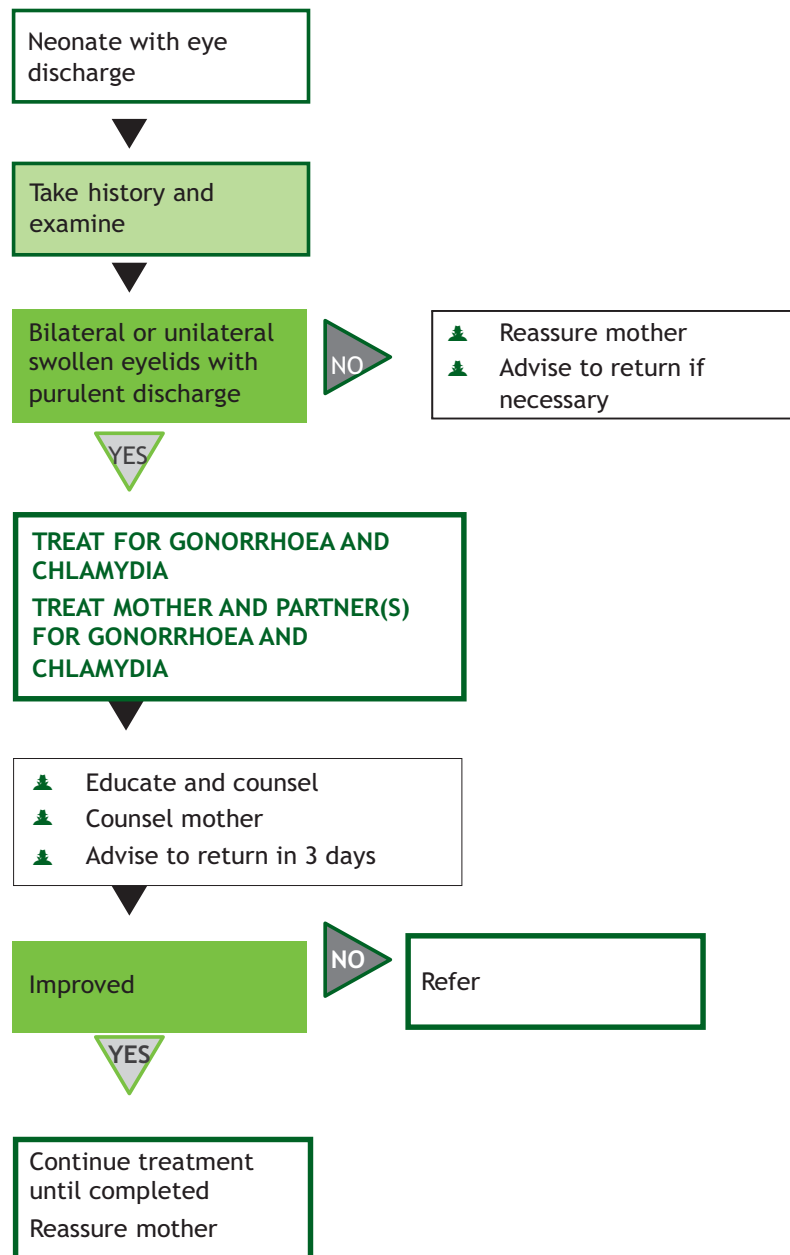

Treatment Options for Neonatal Conjunctivitis

Recommended Syndromic Treatment

- Ceftriaxone, 50 mg/kg by intramuscular injection, as a single dose, to a maximum of 125 mg

Alternative Regimen where Ceftriaxone Is Not Available

- Kanamycin, 25 mg/kg by intramuscular injection, as a single dose, to a maximum of 75 mg
- OR**

- Spectinomycin, 25 mg/kg by intramuscular injection, as a single dose, to a maximum of 75 mg

Note:

- Single-dose Ceftriaxone and Kanamycin are of proven efficacy. The addition of Tetracycline eye ointment to these regimens is of no documented benefit.

HIV/Clinical disease 1,2 (Mild) 3,4 (Severe)

Clinical disease 1,2 (Mild) 3,4 (Severe) is an infectious disease, caused by the human immuno-deficiency virus (HIV), in which the body's defense system is destroyed, resulting in the failure of the body to fight infections. The disease in its final stage is known as Clinical disease 1,2 (Mild) 3,4 (Severe),.

AIDS is a very serious STI with no vaccine presently available; primary prevention is the only tool to control HIV/ Clinical disease 1,2 (Mild) 3,4 (Severe),,. Hence it is very important to know the mode of transmission and the preventive measures, and how to identify and detect early and counsel and refer patients for treatment and management.

Stages of HIV/AIDS Infection

- **Initial Stage:** In this stage of the disease most (60 percent) of the patients remain asymptomatic. But in a few cases the patient may develop flu-like symptoms after 1-3 weeks. The fever in these cases may continue from 1-3 weeks.
- **Window Period:** The HIV/Clinical disease 1,2 (Mild) 3,4 (Severe),, virus takes about 3-6 months for antibodies to become detectable in the blood, from the time of entering the body. This period is called the window period.
- **Asymptomatic HIV/AIDS Infection:** In some cases, the person may remain in the carrier stage for up to 15 years without developing any signs/symptoms.
- **Symptomatic Stage, AIDS:** Of the HIV/ Clinical disease 1,2 (Mild) 3,4 (Severe),, carriers, about 50 percent after 8 years and 60 percent after 15 years develop full-blown Clinical disease 1,2 (Mild) 3,4 (Severe),.

Clinical Features

Clinical disease 1,2 (Mild) 3,4 (Severe),, is suspected if two of the major and one of the minor signs are present.

Major Signs

- Weight loss (10 percent of body weight).
- Recurrent/prolonged fever lasting more than 1 month.
- Chronic diarrhoea lasting more than 1 month.
- Painful genital ulcer.

Minor Signs

- Persistent cough lasting more than 1 month.
- Purplish-blue skin rash that does not disappear.

- Thrush in mouth or throat.
- Swollen lymph nodes.
- Deteriorating blisters and ulcers from herpes spreading beyond the lips and genitals.

Transmission of HIV/Clinical disease 1,2 (Mild) 3,4 (Severe),

HIV is spread when blood, semen, or vaginal fluids of an infected person come in contact with the blood or body fluid, through a breach in the mucous membrane or the skin, of another person.

Modes of Transmission

- Through sexual intercourse, the virus can pass from men to women or vice versa in heterosexuals, and from men to men in homosexuals, or through any other form of sex where a breach of the mucous membrane or the skin occurs.
- Contaminated blood transfusion or infected blood or blood products can transmit the virus in 90 percent of cases.
- Contaminated needles, sharps, razors, and other skin-piercing instruments can pass the virus in 5-10 out of 1,000 cases. Therefore, drug addicts who share needles are at risk.
- Vertical transmission from an infected mother to her baby can occur during pregnancy or during delivery, or even after birth while nursing. Almost 10 percent of the HIV/Clinical disease 1,2 (Mild) 3,4 (Severe), cases in the world are children, most of whom acquired the infection from their infected mothers.
- Although HIV can be transmitted through breast milk, WHO still encourages breastfeeding in the developing world, because a baby's chances of dying from malnutrition outweigh those of dying from HIV/Clinical disease 1,2 (Mild) 3,4 (Severe) infection.

High-Risk Behaviours

- Having sex with more than one partner or with a spouse who has other partners (commercial sex workers), without using condoms
- Taking infected blood or blood products
- In childbirth, when the virus passes from an infected mother to the child
- Sharing contaminated needles and syringes

Behaviours through Which HIV Does Not Spread

- Talking, sneezing, coughing, or through air
- Insect bite
- Shaking hands with or embracing an infected person
- Sharing a toilet or swimming pool with an infected person
- Playing or eating together
- Sharing towels or clothes
- Living together with or taking care of a person with HIV/ Clinical disease 1,2 (Mild) 3,4 (Severe),,, or going to the same school as an infected person
- Having sex with a mutually faithful person who does not have Clinical disease 1,2 (Mild)

- 3,4 (Severe)
- Correct and consistent use of condoms

Treatment

Antiretroviral (ARV) drugs inhibit the replication of HIV. When antiretroviral drugs are given in combination, HIV replication and immune determination can be delayed, and survival and quality of life improved. Symptomatic treatment can be given to ease the symptoms.

Prevention of HIV/Clinical disease 1,2 (Mild) 3,4 (Severe)

- Promoting Safe Medical Practices.
- Processing (decontamination, cleaning, and sterilization) of all needles, syringes, and surgical instruments.
- Strict application of infection prevention measures.
- Destruction of all disposable supplies.
- Performing blood transfusion only when necessary.

Protecting Health Care Providers

- Wearing gloves for all procedures requiring contact with blood or body fluids.
- Wearing gloves while processing surgical instruments; using sterilized or high-level disinfected instruments.
- Laundering soiled linen properly.

Hepatitis

Hepatitis is an inflammation of the liver that stops it from proper functioning. Several different viruses cause hepatitis. They are named the hepatitis A, B, C, D, and E viruses.

All of these viruses can cause acute, or short-term, viral hepatitis. The hepatitis B, C, and D viruses can also cause chronic hepatitis, in which the infection is prolonged, sometimes lifelong, and in some cases can lead to chronic cirrhosis and liver cancer.

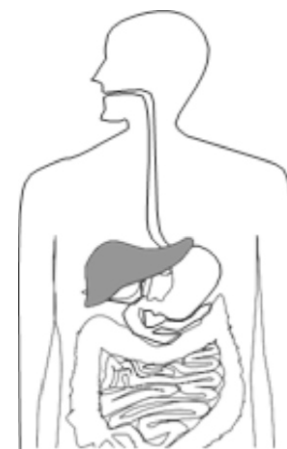

Hepatitis is inflammation of the liver.

Hepatitis B

Liver disease caused by hepatitis B virus (HBV).

Modes of Transmission

- Having contact with an infected person's blood, semen, or other body fluids.
- Having sex with an infected person without using a condom.
- Sharing drug needles.
- Getting a tattoo or body piercing with dirty tools that were used on someone else.
- Getting pricked with a needle that has infected blood on it.
- Sharing a toothbrush or razor with an infected person.
- In the case of an infected mother, transmitting the virus to a child during birth or breastfeeding.

Hepatitis B does not spread by:

- Shaking hands with an infected person.
- Hugging an infected person.
- Sitting next to an infected person.

Prevention

A person can get vaccinated against hepatitis B.

Hepatitis B vaccine is given through three shots. All babies should get the vaccine. Infants get the first shot within 12 hours after birth. They get the second shot at age 1-2 months, and the third shot between the ages of 6 and 18 months.

Older children and adults can get the vaccine, too. They get three shots over 6 months. Children who have not had the vaccine should get it. A person needs all of the shots to be protected from hepatitis B. If a person misses one (or two) of the three shots, s/he should go to the doctor or clinic right away to set up a new appointment.

One can also protect oneself and others from hepatitis by:

- Using a condom at time of sexual intercourse.
- Not sharing drug needles with anyone.
- Wearing gloves if one has to touch anyone's blood or body fluids.
- Not using an infected person's toothbrush, razor, or anything else that could have blood on it.
- Tattooing or body piercing only with clean tools.

Hepatitis C

An infection of the liver caused by the hepatitis C virus (HCV), which is found in the blood of persons who have the disease.

Modes of Transmission

Hepatitis C is spread by:

- Having contact with an infected person's blood.
- Sharing drug needles.
- Getting pricked with a needle that has infected blood on it.
- Being born to a mother with hepatitis C.
- Getting a tattoo or body piercing with unsterilized, dirty tools.
- Receiving a blood transfusion with infected blood or an organ transplant without screening for hepatitis C.
- Having sex with an infected person, especially if he/she or his/her partner has other STIs.



One could get hepatitis C by sharing drug needles.

Hepatitis C does not spread by:

- Shaking hands with an infected person.
- Hugging an infected person.
- Kissing an infected person.
- Sitting next to an infected person.

Contraceptives for Clients with STIs, HIV/ Clinical disease 1,2 (Mild) 3,4 (Severe)

People with STIs or HIV/(Clinical disease 1,2 (Mild) 3,4 (Severe), or who are on antiretroviral therapy (ART) can start and continue to use most contraceptive methods safely. There are a few limitations. However, in general, contraceptives and ARV medications do not interfere with each other. It is not certain whether some ARV medications make low-dose hormonal contraceptives less effective. Even if they do, condom use can make up for that.

Condoms

When used consistently and correctly, condoms provide almost 100 percent protection against STIs, HIV, and (Clinical disease 1,2 (Mild) 3,4 (Severe),).

Intrauterine Contraceptive Devices (Copper-Bearing or Hormonal IUCDs)

Insertion of an IUCD has to be individualized in a woman who is at very high individual risk for gonorrhea and chlamydia (MEC 2015 2/3). Do not insert an IUCD in patients who currently has gonorrhoea, chlamydia, purulent cervicitis, or PID. (A current IUCD user who becomes infected with gonorrhoea or chlamydia or develops PID can safely continue using an IUCD during and after treatment.) A woman with HIV can have an IUCD inserted. A woman with AIDS mild clinical disease (WHO Stage 1,2) can have insertion and continue to use IUCD. Women with sever clinical disease (WHO 3,4) should not have an IUCD inserted unless she is clinically well on ART. (A woman who develops AIDS while using an IUCD can safely continue using the IUCD.) Do not insert an IUCD if the client is not clinically well.

Female Sterilization

If a client has gonorrhoea, chlamydia, purulent cervicitis, or PID, delay sterilization until the condition is treated and cured. Women who are infected with HIV, have Clinical disease 1,2 (Mild) 3,4 (Severe) or are on ART can safely undergo female sterilization. Special arrangements are needed to perform female sterilization on a woman with Clinical disease 1,2 (Mild) 3,4 (Severe). Delay the procedure if she is currently ill with Clinical disease 1,2 (Mild) 3,4 (Severe), related illness.

Vasectomy

If a client has scrotal skin infection, an active STI, or swollen, tender tip of the penis, sperm ducts, or testicles, delay sterilization until the condition is treated and cured. Men who are infected with HIV, have Clinical disease 1,2 (Mild) 3,4 (Severe) or who are on ART can safely undergo vasectomy. Special arrangements are needed to perform vasectomy on a man with Clinical disease 1,2 (Mild) 3,4 (Severe). Delay the procedure if he is currently ill with Clinical disease 1,2 (Mild) 3,4 (Severe), -related illness.

Oral Pills, Injectables, and Implants

STI clients can safely use contraceptive pills, injections, and implants. These do not affect the course of disease and are without any harmful effects or interaction with the medicines being taken.

17

MALE AND FEMALE INFERTILITY

Introduction

Despite a high fertility rate in Pakistan, approximately 21.9 percent of couples in the country suffer from infertility.

Infertility is considered primarily a women's problem, and the role that men play in conception is often overlooked. Infertility thus creates psychological, emotional, and social problems for women because they are blamed for not being able to produce children, whereas men are often ready to marry again without seeking medical attention for the causes of possible male infertility.

Infertility is a highly sensitive problem for couples. They may be helped to conceive through counselling/education, diagnosis, and correct guidance for treatment. This task can be performed by health care providers in the community who can assist in diagnosis, education, and counselling and provide guidance. They should also refer cases of sexual dysfunction, which may be age-related, and are influenced by health and psychosocial factors.

Health care providers should be able to:

- Give the couple moral support and encouragement.
- Counsel couples about infertility.
- Educate couples about possible causes of infertility.
- Take a proper history.
- Do a thorough physical examination.
- Refer couples to infertility centres or specialists.

Role and Responsibilities of Family Planning Services

The evaluation of infertility is directed mainly to the couple but also involves the family and the community. Given the many factors that affect normal fertility, it is important to reassure the couple and manage the expectations of the couple and their families about the many challenges of planning a family and having children.

During the initial evaluation of infertility, it is very important to perform the evaluation of the couple together so they can better understand the important concepts of fertility and fecundability.¹ Counselling should focus on personal and environmental factors that can affect the couple's fertility. Health services must acknowledge the pressure from families and communities to have children. They should also emphasize the need for support from families and the community, especially if infertility is confirmed and further evaluation and treatment need to be performed at a specialized medical centre.

Definitions

Secondary Infertility: Failure of a couple to become pregnant after 12 months of regular intercourse without use of contraception among couples who have had a previous pregnancy. Couples wherein either the male or female partner has undergone permanent sterilization, either vasectomy or tubal ligation, are included in this category.

If woman age is above 35 years then consider work up after 6 months.

Infertility/Fecundity: Failure of a couple to become pregnant after 12 months of regular intercourse without use of contraception.

Fertility

Normally, fertile couples who have sexual intercourse without contraception during the fertile period have about a 20 percent chance of conception in each menstrual cycle (fecundability). In each cycle, sexual intercourse during the fertile period and good semen quality improve the chance of becoming pregnant. The fertile period takes place approximately 5-6 days before ovulation, up to the day of ovulation. The greatest chance of becoming pregnant occurs when intercourse happens 1-2 days before ovulation. The quality of semen improves after 2-3 days abstinence. Regular intercourse (approximately two or three times per week) beginning soon after the menstrual period stops increases the chance of becoming pregnant. However, as the time period without becoming pregnant increases, fecundability in the next menstrual cycle decreases.

Fecundability depends on other important factors, including maternal and paternal ages. Couples should consider their ages in planning when to become pregnant and have children.

Infertile couples who eventually become pregnant are not more likely to experience miscarriage or stillbirth compared to fertile couples of the same age.

Causes of Infertility

- Unexplained: no identifiable cause (28 percent)
- Male factor (23 percent):

¹ Fecundability: Probability of becoming pregnant in a single menstrual cycle.

- Low sperm quality (sperm count, motility, morphology)
- Hormone abnormalities due to disease or medications that affect the hypothalamus or pituitary gland
- Disorders of male reproductive organs:
 - Genetic/chromosome abnormalities
 - Cryptorchidism (failure of testicular descent during foetal development)
 - Testicular cancer
 - Varicocele (dilation of veins in the scrotum)
 - Defect in specific hormones and hormone receptors
 - Exposure to tobacco (smoking), infection, specific medications, environmental hazards, and toxins
- Previous vasectomy (in cases of secondary infertility)
- Female factor (44 percent):
 - Decreased or absent ovulation
 - Pelvic adhesions (due to pelvic inflammatory disease, previous abdominal or pelvic surgery, abdominal or pelvic infections such as appendicitis or pelvic tuberculosis)
 - Abnormalities of female reproductive organs:
 - Endometriosis
 - Uterine fibroids and other uterine abnormalities such as uterine septum
 - Blockage of fallopian tubes
 - Cervical infection and narrowing of the cervix due to cancer or previous surgery
 - High prolactin hormone level
 - Previous tubal sterilization (in cases of secondary infertility)
- Coital factor: interaction of sperm and cervical mucus (5 percent):
 - Antibodies to sperm

Risk Factors in Both Male and Female

- Older age
- Smoking
- Heavy alcohol use
- Stress
- Infection of reproductive organs, including sexually transmitted infections (STIs)
- Surgery to abdomen and reproductive organs
- Exposure to environmental hazards and toxins including radiation, pesticides, lead, and mercury

Risk Factors in Female

- Oligomenorrhoea (> 6 weeks between each menstrual cycle) or amenorrhoea (absence of menarche by age 16 or absence of menses for more than 6 months in women who were previously menstruating), which leads to decreased or absent ovulation
- Overweight or underweight: optimal BMI is 18.5-25 kg/m² (approximately 50-60 kg)

- for women who are 1.6 meters tall)
- Too much caffeine intake: approximately more than 10 cups of tea or 2 cups of coffee per day
- Too much exercise
- Eating disorders

Initial Approach to an Infertile Couple at the Family Planning Clinic

Couples should be evaluated for infertility together after 12 months of unsuccessful conception despite regular intercourse. Couples over age 35 should be evaluated after 6 months.

Counselling should emphasize normal fertility, including the fertile period, causes of infertility, and ways to improve chances of conception in each menstrual cycle. Couples who continue to have difficulty becoming pregnant should then be evaluated by a trained physician.

Initial Recommendations/Prevention of Infertility

- Have regular intercourse during the fertile period.
- Plan to start having children before 35 years old, if possible.
- Improve body weight.
- Minimize stress.
- Stop smoking.
- Decrease or stop alcohol use.
- Decrease caffeine intake.
- Eliminate exposure to environmental hazards and toxins.
- Avoid exposure to STIs by using condoms and limiting the number of sexual partners.

Secondary Evaluation of an Infertile Couple

The next step in the evaluation of infertility should include a complete medical history and physical examination. This evaluation identifies risk factors that affect the couple and can provide important information about recommendations to increase the couple's chance of becoming pregnant. Men who have had children with a different female partner are less likely to have infertility due to male factors.

The following screening tests may be helpful during the medical evaluation:

- STIs (both male and female partners)
- Polycystic ovarian syndrome (PCOS) (in female): Polycystic ovary syndrome is a disorder in women characterized by decreased or absent ovulation and increased androgen hormone level (increased hair growth, acne, male pattern balding) with no other known causes for these conditions. Abnormalities in cholesterol levels and insulin resistance (for example, diabetes) are common in women with PCOS.) Vitamin D deficiency is also common in these women.
 - Thyroid disease - T3, T4 and TSH Levels. (female): Thyroid disease may cause an increase in prolactin hormone level that can affect ovulation and decrease fertility..

Goals of the Medical Evaluation of an Infertile Couple

- Obtain complete medical history of both husband and wife with the following key elements (see Table 17-2).
- Perform physical examination with the following key elements:
 - Male:
 - Confirm appropriate development of male anatomy
 - Assess presence of surgical scars
 - Female:
 - Measure vital signs including height in meters, weight, blood pressure and BMI.
 - Confirm appropriate development of female anatomy
 - Assess hair growth and pattern, acne (to evaluate potential diagnosis for PCOS)
 - Assess presence of surgical scars
- If infertility is diagnosed based on the couple's history, discuss the following potential concerns:
- What does infertility mean?
 - What are the potential causes of infertility? Do any of these causes affect the couple?
 - Is there a need for further evaluation? If yes, what additional tests are needed? Should the couple be referred to a specialized medical centre?
 - What are the treatment options? Should the couple be referred to a specialized medical centre?
 - What recommendations can be made at the end of the initial visit? (See "Initial Recommendations/Prevention of Infertility" above.)
- Discuss expectations about chances of successful conception and future pregnancies (if known based on history and examination).
- Provide reassurance regarding the diagnosis and plan of care. Empower the couple by emphasizing what they can do as a next step

Table 17-2. Key Elements of Medical History to Evaluate a Couple for Infertility

	Components of Medical History
Couple	<ul style="list-style-type: none"> • Do you have any children together? Have you experienced any pregnancy loss, such as miscarriage? • How long have you been attempting to conceive? • How often do you have sexual intercourse?
Male	<ul style="list-style-type: none"> • Medical history: <ul style="list-style-type: none"> – Do you have any medical problems? – Do you take any medications? • Surgical history: <ul style="list-style-type: none"> – Did you ever undergo a vasectomy? • Family history: <ul style="list-style-type: none"> – Is there anyone in the family born with chromosome abnormalities (such as Down syndrome) and congenital anomalies? • Sexual history: <ul style="list-style-type: none"> – Have you fathered a pregnancy? If yes, were these pregnancies with your current partner? What were the outcomes of these pregnancies (live birth, miscarriage, ectopic, induced abortion)? – How many wives do you have currently.? Number of previous marriages? – Do you have any history of sexually transmitted infections? If yes, when? Were you treated for these infections? – History of tuberculosis in past and family history of TB. & any family history of TB • Social history: <ul style="list-style-type: none"> – Do you smoke cigarette or Huqqa ,chew Tobacco? If yes, how much?

Components of Medical History	
Female	<ul style="list-style-type: none"> • Medical history: <ul style="list-style-type: none"> – Do you have any medical problems? High cholesterol level, high blood pressure, or heart disease? Diabetes? Thyroid disease? – Do you take any medications? • Surgical history: <ul style="list-style-type: none"> – Did you ever undergo a tubal ligation? – Have you ever had any surgery in your abdomen or vagina? • Family history: <ul style="list-style-type: none"> – Is there anyone in the family born with chromosome abnormalities (such as Down's syndrome) and congenital anomalies? • Obstetric history: <ul style="list-style-type: none"> – How many times have you been pregnant? – Do you have any children? – Have you experienced any miscarriages, ectopic pregnancies, or induced abortions? How many? How far along was your pregnancy? – Is your current husband, the father of each of your pregnancies? • Gynaecologic history: <ul style="list-style-type: none"> – How old were you when you began having periods? How often (per month, per year)? Can you predict when your menstrual cycle will begin? – Do you have any history of abnormal Pap smear? If yes, what treatment(s) did you receive? – How many marriages do you have currently? Number of previous sexual partners? – Do you have any history of sexually transmitted infections? If yes, when? Were you treated for these infections? • Social history: <ul style="list-style-type: none"> – Do you smoke? If yes, how much? – Do you drink alcohol? If yes, how much? – Do you drink tea, coffee, or other caffeinated drinks? If yes, how much?

Follow-Up

Depending on availability of resources at the local health centre, follow-up may include the following evaluation at a specialized medical centre:

- Semen analysis:
 - A standard semen analysis to evaluate semen quality. Collect semen sample that is collected after 2–7 days of abstinence and submitted to a special laboratory within 1 hour of collection. If a low sperm count is found, genetic

studies of the husband may be helpful.

- Assessment of uterus and fallopian tubes:
- Hysterosalpingographic studies or laproscopic surgery may be performed to evaluate the female pelvic anatomy to identify potential causes of infertility.
- Assessment of ovulation:
 - Special serum laboratory studies may help in the evaluation of ovarian function such as progesterone level at Day 21.
 - 12th day ultrasound scan for dominant follicle.

Treatment Options

- Provision of education and counseling about the fertile days in the menstrual cycle.
- Treatment of medical conditions, including infections, that may affect the couple's fertility.
- Surgery for treatment of endometriosis or diseases affecting male and female reproductive organs.
- Treatment for decreased or absent ovulation that may include hormone medications.
- Assisted reproductive technologies such as in vitro fertilization.

18

CONTRACEPTIVE SECURITY

Introduction

International assistance for family planning (FP) has been shrinking at a time when many FP programmes in developing countries are experiencing shortages of contraceptives. A reliable, adequate supply of good-quality contraceptives, such as IUCDs, oral contraceptive pills, condoms, Implants and injectables, is a critical component of successful FP/reproductive health (RH) programmes. It is also a basic requirement for guaranteeing good RH choices to women and men, one of the objectives of the International Conference on Population and Development (1994 Cairo) Programme of Action. Supplies are often ignored in FP/RH programmes, and funding shortages, combined with both a surge in contraceptive use and insufficient institutional capacity, sometimes make it difficult to establish and maintain a secure supply of contraceptives. London Summit 2012

Contraceptive security is achieved when a programme is able to forecast, finance, procure, and consistently deliver a sufficient supply and choice of safe, reliable, and affordable contraceptives to every client needing them. Therefore, understanding constraints related to contraceptive supplies would help programme managers/health care providers to better plan for their continued supply and availability.

Definition

Contraceptive security exists when people are able to choose, obtain, and use quality contraceptives, including condoms, according to their needs for FP and prevention of HIV/sexually transmitted infections; more simply, it is the increased availability of contraceptive supplies.

Elements of Contraceptive Security

- **Clients:** Programmes that increase contraceptive security serve the entire market of current and potential users, from those who require free supplies to those who can and will pay for commercial products.
- **Commodities:** Contraceptive security means that users can make informed choices from a full range of methods and services of high quality and at affordable prices.

Ensuring access to short-term, long-term, permanent, and natural methods is part of contraceptive security.

- **Long-Term Assurance:** Contraceptive security means that the methods and services are available according to clients' need. This requires leadership and long-term commitment from all stakeholders, i.e., the public sector, private sector, and donors. Even households must contribute by helping to pay for their methods when they can.

Requirements of Contraceptive Security

The capacity to ensure that supplies reach the men and women who need and want them is crucial. Policy, political commitment, and economic factors play an important role; adequate funding alone cannot guarantee contraceptive security.

Capacity

Contraceptive supply security requires a minimum set of institutional capacities as detailed below:

- **Logistics:** Programmes need the capacity to estimate current and future contraceptive requirements, procure required contraceptives, track and manage inventories at all levels of the supply chain, and safely store and deliver products to the individuals seeking services, when and where needed. Efficient logistics management systems can often prevent temporary stock-outs and shortages of supplies. Logistics Manual strictly followed/CLMIS.
- **Financial Sustainability:** Budgetary cycles, international procurement processes, and time required for supply chain dictate that funding be reliable and predictable for a minimum of 3-5 years. Sustainability usually requires taking advantage of financing options that relieve the burden on the public sector, including market segmentation, public sector cost recovery, social marketing, and commercial and social health insurance.
- **Information Systems:** Effective information systems produce reliable and useful data critical to policy and programme planning, priority setting, logistics, evidence-based interventions, programme implementation, and monitoring. These are also important for galvanizing program support and for raising awareness among policymakers and other potential advocates. Re draft as per CLMIS. Tertiary care hospitals and private sector as per mechanism of supplies.
- **Advocacy:** Key stakeholders, parliamentarians, and concerned public and private organizations play an important role in raising awareness and mobilizing political support for supplies. These activities encourage government, funding partners, and others to direct their resources to ensure the availability of commodities, to reduce barriers, including taxes, price controls, and advertising, to promote consumer-centred strategies, and to improve the funding environment.

Environment

Conditions over which programmes have little or no control also can influence contraceptive supply security, such as:

- **Legal and Policy Environment:** Favourable laws and regulations to facilitate import of contraceptives/their raw materials, and support to expand the commercial sector, also

encourage a range of approaches to enable distribution of contraceptives and their promotion or advertisement.

- **Regulatory Agency:** With adequate authority and independence, drug and device regulatory agencies ensure the safety, efficacy, and quality of drugs (including contraceptives) by establishing a legal framework specifying requirements for manufacturing, importing, registration, certification, labelling, dispensing, and reporting of product problems.
- **Political Commitment:** A government committed to FP works actively to eliminate barriers to its promotion and access, ensures contraceptive access, urges other stakeholders, such as social marketing and commercial providers, to play a meaningful role, and, when necessary, shoulders a significant share of FP costs.

Commercial Sector

When there is a vibrant commercial contraceptive market, the burden of providing supplies is not borne by the public sector only, but subsidized public sector supplies can be distributed efficiently.

Out-of-pocket payments account for 50-90 percent of health care spending in developing and transitional countries, compared to less than 30 percent in industrialized countries, where insurance and other third-party mechanisms share the cost burden. Many who pay for their own supplies purchase them from the commercial sector, which includes private hospitals/clinics, pharmacies, employers, markets, and shops.

The commercial market share for FP varies significantly across developing countries. Whether the commercial sector can play a major role in contraceptive security depends on a number of factors, including a country's public sector policy, income levels, contraceptive demand, and distribution channels.

Policymakers who consider these factors in realistically assessing the future market shares can be better able to ease the public sector burden and thus increase contraceptive supply security.

Causes of Contraceptive Shortages

The factors that can lead to contraceptives shortages include growing demand for contraceptives, shifting national priorities, lack of in-country capacity, and inadequate coordinating mechanisms at the national level.

Conclusion

Many elements are involved in securing supplies of contraceptives and condoms so that people are able to reliably choose, obtain, and use them (see figure below). Within the broader context-determined by socioeconomic conditions, political and religious concerns, competing health priorities, and health sector reforms, etc.-commitment and coordination by government, donors, and other stakeholders at all levels help ensure supportive policies, resource mobilization, and effective allocation of resources. Human and institutional capacity affects the entire system and must exist for a range of functions, including forecasting, procurement, logistics, service delivery, advocacy, and data-driven decision-

making. Governments, the private sector (employers, insurers, and other third parties), households, and donors are all key participants in contraceptive financing (capital), which along with forecasting and procurement, ensures that programmes have the necessary supplies. Furthermore, the bottom line for contraceptive security is client utilization, which results from client demand and successful efforts in fulfilling that demand with distribution and service provision through a range of public and private sector channels.

Figure 18-1. Reproductive Health Commodity/ Security Framework



Source: Hare L et al. (eds.) and Bornbusch A (ed.). 2004. SPARHCS: Strategic Pathway to Reproductive Health Commodity Security. A Tool for Assessment, Planning, and Implementation. INFO Project/Center for Communication Programs, Johns Hopkins Bloomberg School of Public Health: Baltimore, Maryland.

Working out Monthly Contraceptive Requirement— Replenishment for RHS-A Centre/MSU/FWC/FHC

Step I	Work out Average Monthly Consumption (AMC) of each commodity for the last 3 months.
Step II	Multiply AMC by number of months' stock to be maintained at facility level. Currently, stock level is to be maintained for 3 months at facility level. Therefore, multiply AMC by 3; this is the desired stock level.
Step III	Work out requirement/replenishment by subtracting available stock (last entry in the month) as per CLR-5 (Stock Register) from desired stock level as calculated in Step II.

Symbolically:

Replenishment = Desired Stock - Available Stock

Example:

Contraceptive Performance of a Facility for Last 3 Months

	Condoms	Oral Contraceptives (COC)	CuT 380A	Magestron
February 2016	1,000	50	20	20
March 2016	1,400	40	22	18
April 2016	1,500	30	18	19
Total	3,900	120	60	57
AMC	$3,900/3 = 1,300$	$120/3 = 40$	$60/3 = 20$	$57/3 = 19$
Desired stock level	$1,300 \times 3 = 3,900$	$40 \times 3 = 120$	$20 \times 3 = 60$	$19 \times 3 = 57$
Available stock	3,000	150	45	60
Replenishment required	900	Zero	15	Zero

Couple Year of Protection (CYP)

Conversion Formula for Contraceptive Couple Year of Protection(CYP)	
Condom	Number of UNITS/144-
Oral Pill	Number of CYCLES/15
IUCD	Number of INSERTIONS x 3.5
Implants	Number of Insertion x 5
Injectable	Number of VIALS/5
Implant (Norplant)	Number of INSERTIONS x 5
Contraceptive Surgery (CS)	Number of CASES x 12.5

Source: MoPW, Islamabad.

PWD's List of Contraceptive Logistic Record/Reports (CLRS)

- **CLR-1** Contraceptive Procurement Status Card
- **CLR-2** Country/Provincial Contraceptive Stock Card
- **CRL-3** Contraceptive Receiving Report- Central level available
- **CLR-4** BIN Card
- **CLR-5** Contraceptive Stock Register
- **CLR-6** Contraceptive Requisition Form
- **CLR-7** Contraceptive Issue and Receipt Voucher (IRV)
- **CLR-8** Warehouse Contraceptive Stock and Dispatch Report
- **CLR-9** District Contraceptive Stock & Sales Ledger
- **CLR-10** Analysis of District's Contraceptive Stock & Sales
- **CLR-11** District Contraceptive Stock Report
- **CLR-12** Contraceptive Dispatch Order
- **CLR-13** Service Outlets Contraceptive Stock & Sales Ledger
- **CLR-14** Sale Outlets Contraceptive Stock & Sales Ledger
- **CLR-15** District Contraceptive Stock Report

19

TRAINING/HUMAN CAPACITY DEVELOPMENT

Training

Training is a process which deals primarily with transferring or obtaining knowledge, attitudes and skills needed to carry out a specific activity. Training should be based on the assumption that there will be an immediate real life application of the physical or mental skill being learned (as differentiated from education, which is most often directed toward future goals).

It is a process of staff development for improving the performance of healthcare providers with assigned job responsibilities on Family Planning services. It is a program designed to strengthen the competencies of healthcare providers. It ensures that health workers already providing services have the opportunity to update their knowledge and skills or mastery of techniques according to the latest scientific information and standardized practices.

The principles of learning in training

Training materials and methods of learning designed for In-service training has to consider adult learning principles with mastery learning which include behavior modeling and competency based and humanistic training methods.

The design and delivery of the training program should include:

- Creation of a learning environment in which participants feel safe, respected, and valued.
- Learning objectives must address the three learning domains: knowledge, skill (psychomotor, communication, clinical decision making) and attitude or affective.
- Interactive approaches that ensure the training activity recognizes and builds on the existing skills, knowledge, and experience of the learners.

- Approaches that allow for application of new content, and foster higher-level cognitive processes such as critical thinking, analysis, and decision-making skills.
- Use of a variety of training methodologies.

Training needs assessment

The training program development process should begin with a training needs assessment. The purpose of a needs assessment is to determine whether a training need exists, and, if it does, what type of training program will address the need. Training programs are implemented to transfer the skills, knowledge, and/or attitudes to a particular target audience that are necessary to perform specific functions or tasks. Information about the target audience, their expected roles and responsibilities, their current knowledge, attitudes, and skills, and the context in which they are working are essential in developing an effective training program. Data and findings from an assessment help to ensure that training activities are aligned with national priorities and programs and that the training program responds to participants' needs. Needs assessment improves focus towards sustainability of in-service training programs.

A performance needs assessment is a particular type of needs assessment that is conducted to determine the cause of a gap in performance and to determine whether or not the gap should be addressed through training or some other type of intervention. A performance gap is the gap between what an individual is currently doing, and what they should or need to be doing. If the root cause of a performance gap is related to a lack of knowledge, skills and/or appropriate attitudes, then training will be an appropriate intervention.

In-service training need assessment has to be undertaken by DOH and/or DOPW and training institutes in collaboration with development partners. There are different data collection techniques to conduct training needs assessment. These may include direct observation, key informant interviews, self-assessments, focus group discussions, review of existing training evaluation data, and review of service delivery data.

Guideline for planning Training

Training planning at all levels shall be based on objective data and information that indicate the needs for training and capacity building of staff. The planning of training should start well in advance of the event and should involve DoPW and /or DOH and training institutes.

Trainer Selection

Once they attend the basic training, participants can be recruited as potential trainers if they perform well on pre/posttest, have demonstrated high- level participation and enthusiasm and received a good feedback from trainers. After receiving a TOT course, participants' facilitation skills are assessed and their result shall be achieved in the trainers'

database at the level of training institutes. Any training institution shall access the national and regional database. The institutions shall continually receive updated information on the trainers' pool. If the need arises, training institutions have the mandate to invite trainers with specific expertise from abroad.

Trainers' Selection criteria

- For anyone to deliver/facilitate an training course he/she has to complete a training of trainers' course in the respective training or he/she should have completed a basic/advanced training of the course and have taken standardized training skills course.
- Trainers must be selected from the national or regional pool of trainers in the data base. The pool of trainers' data base shall be prepared by DOH/DoPW. This data base shall be regularly updated by the DOH & DoPW and will be shared to training institutes.
- The training institution shall select trainers fulfilling the above criteria. Training institutions shall notify the list of trainers before conducting a training to the respective department.

Level of trainers

These categories are important in defining who will give what type of training as various trainings may require different levels of trainers. During course design, the trainer type sought should be defined considering the level of the training. Here is the list of trainer types.

Basic Trainer: A person who is expert in his/her field and proficient service provider, who has completed a **training skills** course which focuses on learning the skills necessary to transfer her/his expertise to others effectively and served as a co-trainer for one or more training courses for service providers.

Advanced trainer: A proficient and experienced trainer with adequate skills necessary to effectively transfer her/his training expertise to others and has been a lead trainer for one or more courses.

Master trainer: An individual who is a lead trainer for a number of trainings and has experiences in **instructional design training skills** and training needs assessments/evaluation and has facilitated a **training of trainer (TOT)** courses.

Trainers Team composition

Training courses which take over days and include various topics require a team of trainers. The team should be composed of at least two individuals with complementary styles in skills and knowledge. The trainers are required to be: technically competent in their subject area, should have to be trained as trainers, have a sound experience as trainers, must also be oriented with the trainees work situation and are willing to participate in the whole training activity as a lead or co-trainer.

In a team of trainers, there needs to be a Team Leader or course director who is responsible for forming the training team or facilitate the process by working with the training coordinator/director.

Participant Selection

Selecting the right candidates for training is crucial to best training outcome. As described above, a performance needs assessment should have been conducted to determine what the target audience for the training is currently doing and what they should be doing at their job site. If the training program is focused on a new program area and/or revised national guidelines the following criteria should be taken into consideration while selecting participants for a training event:

- Participants should be working at a facility that provides (or is planning to initiate) the type of services that are the subject of the planned training.
- Participants should have the minimum educational qualifications required to provide the services for which the training is planned.
- Participants should be interested in providing the service at their workplace and permitted to do so in their scope of practice.
- Participants should not have received the training before.
- Participants should have support from their workplace supervisor or manager to participate in the training, and to later provide the service.
- Trainee sending institutions need to find ways to get the participant provide the service following the training for a long period of time.
- Confirmation or verification has to be made as to participants coming to the training do fulfill the selection criteria. Any participant who is identified not to fulfill the criteria is subject to termination from the training.

Training Curriculum Standardization

- Any adapted or developed training material shall fulfill criteria set for standard training packages in Pakistan. (See annex II)
A standard training package shall contain the following:
- Participant's manual with course schedule, course syllabus, course content, pre-course knowledge assessment questionnaire, daily and end-of-course evaluation forms, learning guides and checklists for clinical skills acquisition and assessment and handouts for group work/exercises.
- Trainer's/Facilitator's Guide containing information in the participant's handbook as well as the course outline, session outline and descriptions, instructions for facilitation and presentation of the course content, comprehensive facilitator's notes with supplementary content material, pre-course knowledge assessment questions and answers, worksheets with answers, guidelines for evaluation of the training.
- Reference Materials with evidence-based, essential need-to-know information about the subject matter that is consistent with National guidelines.
- Audiovisual Tools including videos, VCDs or DVDs, as appropriate.

Training Session Preparation

The course should assume full responsibility for ensuring that everything is prepared for the successful implementation of training. The trainers should coordinate with other

members of the training team to prepare for and implement the training.

Most training events are organized into multiple training sessions, each of which covers a specific training topic or activity. Trainers should review the session plan before the training. During the planning and preparation phase, trainers should ensure that session plans are created and personalized for every session of the training.

Training Site Selection and Preparation

The training Lead should visit the training site ahead of time to ensure that it meets the site selection criteria for the didactic (classroom) component of the training and possible clinical service component. Any classroom teaching facility used should be large enough to accommodate the anticipated number of participants, with ample space for them to move about in the room. The seating arrangement should encourage face-to-face participant interaction (e.g., a standard U-shaped or circle seating arrangement). The classroom site should preferably have 2–3 breakout rooms for smaller group work.

If the training requires clinical training practices the sites needs to meet the following criteria:

- It should be providing the clinical service for which the training is to be conducted.
- The clinical services being provided should meet updated national service delivery standards (which should be based on international standards).
- The client load or caseload at the site should be sufficient to allow participants to perform enough procedures to attain competency within a relatively short period of time,
- It should be following standard infection prevention practices.
- The site should have adequate staffing, so that the training event does not disrupt routine activities.
- It should have adequate examination rooms, procedure rooms, and recovery rooms/areas.
- The site should have the necessary training equipment and supplies for conducting training.
- It should be fully equipped and staffed to handle any immediate procedure-related complications.
- Ideally, the site should have a qualified trainer, in-house, available to help implement and/or assist with the training.

Logistics and other arrangements

The training team should be actively involved in the travel and accommodation arrangements of the participants in the training event. Though the trainers may not actually be making these arrangements, it is important that they supervise and be knowledgeable about all of the arrangements being made. It is important that trainers (in collaboration with program managers) should designate a person (or persons) to manage these tasks, if and when any problems arise. The trainers should coordinate closely with that designated person, checking to ensure that the following actions have been adequately completed:

- Letters of invitation for the training have been sent to all participants.

- Letters of invitation have been received by all of the participants.
- Letters of release (from daily work obligations) have been issued to the participants by their supervisors/managers.
- Necessary accommodation arrangements have been made.
- Arrangements have been made for the participants to receive a per diem or allowance.

Following are the steps for implementing an in-service training. Roles and responsibilities of the training implementation team should be clearly defined in order to ensure effectiveness and quality of the training.

A. Steps in implementing Training

A. Pre-Course Activities	
Schedule	Activities
At least 4 weeks Before	Set the training date considering participants' convenience to ensure full participation. Decide on the total number of course attendants. Identify and communicate with trainers. Refer to the "Checklist for Preparing a Training event" (Annex IV). Identify a suitable venue. Arrange for other logistics (such as lunch and coffee/tea breaks, accommodation).
At least 3 weeks Before	Send invitation letters with selection criteria, requesting submission of participant enrolment forms, and providing information about logistics. Inform heads of facilities for the practical attachments. Send invitation to the opening and closing speakers.
At least 2 weeks Before	Prepare necessary materials or training aids and print training documents. Confirm practicum sites and availability of space for practical sessions. Prepare follow-up of invitation letters. Tabulate returned enrollment forms of attendees and check the returned enrollment forms against database for duplication of training. Follow up on facilities not responded.
2 days before Training	Confirm accommodations and logistics (venue, lunch and coffee/tea, breaks, housing, etc.). Prepare final list of trainees and find replacements for those who cannot participate in the training. Confirm that training equipment is functional. Confirm the attendance of the speaker(s) (inviting a speaker is optional)
A day before training	Conduct orientation session for the trainers. Brief trainers on important considerations, as needed. Check that training equipment, materials, and teaching aids are ready. Do final room set-up.

B. Activities During the Training	
Schedule	Activities
Day 1	Registration, introduction, distribute name and training materials. Begin the training by introducing the course. Distribute and collect training data forms from participants. Administer pre-course knowledge assessment (pre-test). Collect travel and accommodation expense receipts (when applicable). Verify the participants against the first list and the criteria set for it. Make a logistic announcement.
Ongoing	Observe training, assess learning progress, and identify any new learning needs. Provide continuous feedback to trainees. Confirm attendance of trainers for their sessions. Provide feedback to trainers, as needed. Address participants' and trainers' concerns and complaints, as appropriate. Compile list of participants. Prepare training certificates. Confirm availability of the assigned person for giving a closing remark.
Daily	Conduct daily evaluation on the course and assess training coordination. Analyze the main points and any problems for possible correction in the next day. Conduct facilitators' daily debriefing.
C. Activities at the End of Training	
After closing the training:	Administer post-course knowledge assessment (post-test) and skills assessment (when applicable). Provide answers for the post test questions and discuss them. Administer and collect course evaluation forms Presentation of certificates. Closing speech by assigned speaker. Write overall training report

Reviewing the Day's Activities

Review of the day's activities helps to elicit feedback from the participants and co-trainers. Hence, the trainer should allocate time for the review process at the end of each day's training activities. The trainers/course director should solicit feedback from participants on the day's activities, as this information will assist the trainers in ensuring the course is on track and in making adjustments for future. The feedback can be collected in writing using daily evaluation forms or through discussions.

The trainers' team should conduct daily debriefing at which they review participants' feedback on the day's activities in order to make adjustments as needed.

Consider the following during the debriefing session

- Get each trainer's perspective on the activities covered during the day. Give opportunities for trainers to self-assess themselves and they should also receive feedbacks from the other trainers on how well they lead the sessions. -Review participants' feedback and try to address their concerns if they have any,
- Discuss each trainer's role for the following day's session.
- Prepare the classroom, rearranging seating (if necessary).
- Set up audiovisual equipment (flipcharts, markers, overhead projectors, PowerPoint presentations, videos) and check that the anatomic models and other items needed for simulated practice.

Reporting on the Training Event

The training coordinator should complete a training event report within 2 weeks after completion of the training event. The training event report should capture the main points of the training event (e.g., the name of the training, the number of days for the training, the names and number of participants and trainers, and the name of the training site, including district, region, or country).

The training event report should also capture the number of participants who successfully completed the training and the scores that they achieved in the pretest and the post-test, including the outcome of the skills assessment (if conducted) for each participant. The training event information should be organized in a standard format that will assist in recording the information in a standardized training database. Training institutes are expected to send the report to the respective DoH or DoPW. (See a Sample Training Report Outline in Annex B)

Training Certification

Certification of participants for training courses is important for recognition as it motivates learners to take on new tasks after the training. Depending on the course nature, a certificate of attendance or of a successful completion or temporary certificates can be awarded.

Certificate of attendance is awarded for training courses that do not require assessment competency such as workshops and refresher courses. For a participant to take a refresher course and thus to be awarded a certificate of attendance s/he is required to have a prior attendance of the course which is confirmed by the training organizer.

Certificate of competency is provided for those training courses that require pre and post course evaluation for competency. A certificate of competency is provided to a participant who gets the minimum score as stated in the training curriculum. Trainees who do not meet the minimum score shall be given adequate/additional time (during the conduct of the training workshop or after returning to their work place) to qualify for certification.

Participants are also required to attend all sessions of the course and submit all the required deliverables to be eligible for certification as learners might have to go back and fulfill a precondition on the job or apprenticeship.

Format of Certificates

Certificates for a given training course should include:

- Type of certificate: certificate of attendance or certificate of competency
- Course title
- Logo of the relevant stakeholders;
- Full name of the trainee
- Name, title, position and signature of the relevant authority.

Annexure-A

Checklist for preparing a training event

<u>Key Activities</u>	<u>Comment</u>
<p>Participant selection and management</p> <p>Review participant selection criteria</p> <p>Clarify responsibility for participants transportation</p> <p>Clarify per diem rate</p> <p>Clarify participants invitation and communication mechanisms (letters, telecommunications, e-mail, fax, etc)</p> <p>Clarify accommodation arrangements</p> <p>Provide participants with the phone, fax, E-mail of the training site/or person making arrangements, if appropriate</p>	
<p>Training Room and other Logistics</p> <p>Suitability, proximity, cost, and facility of training site and venue</p> <p>Ventilation and presence of adequate light in the training hall</p> <p>Availability of adequate audiovisual facilities in the hall</p> <p>Availability of breakout room</p> <p>Refreshment services</p> <p>Set up the training room the day before the course Begins</p>	
<p>Course content and Material Preparation</p> <p>Review course syllabus</p> <p>Review course outline</p> <p>Review the course schedule</p> <p>Review training the guidelines and checklists</p> <p>Study the reverence manual, module and protocol</p> <p>Prepare presentation notes, slides, and handouts</p> <p>Prepare supporting audiovisuals</p> <p>Prepare required models, props, and materials</p>	

Annexure-B

Training Reporting Format/outline

The following major points should be incorporated in a training report.

1. Executive Summary
2. Background and context
3. Purpose and Objectives of the training
4. Training Content
5. Workshop preparation and methodology
6. Highlights of the training
7. Key workshop outcomes
8. Training Evaluation
9. Next Steps
 - Participants' action plans
 - Follow-up
10. Attachments
 - List of participants
 - Training Agenda
 - End of course of evaluation
 - Trainer evaluation

Annexure-C

Checklist for training site selection and preparation

Name of the health facility: _____ Date of visit: _____

A Clinical training site is expected to meet the following criteria.

No.	Criteria	Status		Remark
		Yes	No	
1.	Is the facility in the range of 50 kilometers from the training institute?			
2.	Is a local transport service accessible?			
3.	Does the facility have accommodation facilities (hotel or guest house) in the vicinity?			
4.	Are there required services (for the training) at the facility?			
5.	Does the facility provide the above services all throughout the year?			
6.	Is the facility management seeing the establishment of the training center as an opportunity and willing to collaborate or be supportive?			
7.	How do the staff training profile look like?			How many? Their qualification
8.	Does the facility have at least one trained staff that can provide each of the required services during the trainings?			
9.	What is the average No of clients, for each the required services per week?			
10.	Is the case load at the site sufficient to allow participants to perform the required procedure at a training session?			If the cases are fewer than the No specified for one week, you may mention the number.
11.	Does the facility have at least one separate examination room for each of the required services?			
12.	Does the facility have at least one procedure room for each of the required services?			

Training room				
1.	Is there a training room that can accommodate at least 25 people at a time?			
2.	If there is no training room, is there a room that could easily be turned into a training room with slight renovation?			
3.	Can the facility avail at least one extra small room that can accommodate at least 8 people?			
4.	Is the training rooms located in less traffic area (less noisy)?			
5.	Are there sitting chairs and small tables?			How many?
6.	Is there electric supply and power outlet in the training rooms?			
7.	Which of the following training materials are available in the facility? (please mark separately) <ul style="list-style-type: none"> • Video camera • LCD • Computer • Printer • Photocopier • VCR, TV • Flip chart stands • White board • Models for hands on training (anatomic, pelvic, scrotal etc) 			

Annexure-D:

#	Title	Duration	Course Content
1. TRAINING FOR PROGRAMME EMPLOYEES			
I.	Basic/Long-term Training (Trainees are inducted bi-annually)		
1.	Basic Training Course for Family Welfare Worker (FWW)	24 Months	24 Modules
II.	Advanced Training		
1.	Advanced training of FWWs to become FW Counsellors	3 Months	
2.	Advanced training of FW Counsellors to become FTOs	6 Months	Competency-based Theoretical and Practical Training as per Ministry's prescribed curricula including Country's Demographic Profile; Population Policy; FP Methods; Infection Prevention; FP Counselling; Camp Services
3.	Advanced training of FW Counsellors to become ASTs	5 Months	
III.	Pre-Service Training		
	Pre-service training for FWAs on RH and FP	3 Months	Competency-based Theoretical and Practical Training as per Ministry's prescribed curricula including Country's Demographic Profile; Population Policy; FP Methods; FP Counselling; Camp Services
IV.	In-Service/Refresher Training		
1.	Refresher training for FWWs on RH	4 Weeks	Competency-based Theoretical and Practical Training as per Ministry's prescribed curricula including Country's Demographic Profile; Population Policy; FP Methods; Infection Prevention; FP Counselling; Camp Services
2.	Refresher training for FWWs on FP	2 Weeks	
3.	Refresher training for FWAs on FP	1 Week	Competency-based Theoretical and Practical Training as per Ministry's prescribed Curricula
V.	Orientation of Doctors on Family Planning		
	Orientation Training for MO In charge RHS-A Centres	1 Day	<ul style="list-style-type: none"> • Demographic Situation of Pakistan • Population Stabilization • Islam and Family Planning • Introduction to FP Methods
VI.	Miscellaneous/Other Trainings		
	Training on Teaching Methodology and Training Evaluation for Faculty of: Regional Training Institutes, PWTIs, RHS Training and Master Training Centres	2 Weeks	Competency-based Theoretical and Practical Training as per Ministry's prescribed Curricula including Principles of Adult Learning and Training Evaluation Techniques

#	Title	Duration	Course Content
2. TRAINING FOR NON-PROGRAMME PERSONNEL			
I. Orientation of Paramedics on Family Planning			
1.	Paramedics (LHVs/TBAs Dais/Midwives) from Health/Provincial Line Depts	1-2 Days	<ul style="list-style-type: none"> • Demographic Situation of Pakistan • Population and Development • Islam and Fertility Regulation • Contraceptive Technology
2.	Paramedics of PPSOs	1-2 Days	
3.	Paramedics of NGOs	1-2 Days	
4.	Paramedics of Private Sector	1-2 Days	
II. Orientation Training of Doctors on Family Planning			
1.	Doctors of Health/ Other Provincial Line Depts	1-2 Days	<ul style="list-style-type: none"> • Demographic Situation of Pakistan • Population and Development • Islam and Fertility Regulation • Contraceptive Technology
2.	Doctors of PPSOs	1-2 Days	
3.	Doctors of NGOs	1-2 Days	
4.	RMPs/Doctors of Private Sector	1-2 Days	
III. Orientation Trainings for Miscellaneous Groups			
1.	Training of Medical Students	1 Day	<ul style="list-style-type: none"> • Demographic Situation of Pakistan • Population and Development • Islam and Fertility Regulation • Advantages of Small-Family Norms • Social Mobilization • Male Involvement • Introduction of FP Methods • Contraceptive Technology (Groups 1 and 2)
2.	Training of Nurses/ Student Nurses/ Student LHVs	1 Day	
3.	Training of Community Volunteers/Lady Workers	1 Day	
4.	Training of University/ College/School Teachers, Students	1 Day	

Annexure-E: Standardized Training Packages for providers of DoH and DoPW

Packages for Training of Trainers (TOTs)	Skills addressed	Cadres of the targeted trainees for becoming trainers
For Master Trainers		
4 days standardization on LARCs for DoH	Interval IUCD, PPIUCD, PAIUCD , Interval and PP Implants(BCS Counseling, Record keeping and Infection Prevention will be cross-cutting)	For existing pool of master trainers (Gynecologists) and additional new master trainers at divisional/provincial level
2 days standardization workshop on Contraceptive Technology Update	Provision of Natural and Hormonal Contraceptives(BCS Counseling, Record keeping and Infection Prevention will be cross-cutting)	Designated Master trainers in each province
4 days standardization on LARCs for PWD master trainers	Interval IUCD and Interval Implants(BCS Counseling, Record keeping and Infection Prevention will be cross-cutting)	Designated Master trainers of PWD from Provincial RHS-As
4 days Training Skills Workshop	Adult Learning Principles, Classroom Learning methodologies, Clinical Teaching, Feedback mechanism, Training Preparation and Evaluation.	Designated Master trainers in each province
For Trainers		
3 days TOTs on CTU	Hormonal contraceptive technical update (HCTU) and Interval IUCD; BCS Counseling and Infection Prevention are included	For FWWs, doctors and LHVs
4 days TOTs on LARCs in the postpartum period	PPFP-PPIUD; Postpartum Implants; BCS Counseling and Infection Prevention are also included	For Gynecologist, Female Medical Officers (FMOs), Senior Registrars
6 days TOTs on LARC	Interval IUCD and Implants; HCTU; BCS Counseling and Infection Prevention are in built	PWD trainers)
3 days TOTs on HTSP and Family Planning	Counselling for PPFP methods	Master trainers of the Lady Health worker program

Training Package	Cadre of the participants	Geographic scope	Status of the training package	Training sites
4 days training on Implants and HCTU (includes BCS +counselling)	HCPs (male/female doctors , LHV's and selected FWWs)	Province wide	PWD approved package need revision and endorsement	Provincial or district FPTU/CoEs
4 days standardization training on Postpartum and Post-abortion FP (includes BCS + counselling)	Gynecologist/ registrars/ Postgraduate students Standardization for female medical officer, RHS-A doctors, nurses, LHV's, CMW's	District wide	Package available; endorsed in Punjab for PPIUD, need to add Implant section and post abortion IUD	Provincial FPTU/CoEs
5 days training on LARCs (includes BCS + counselling)	Gynecologist/ registrars/RHS -A doctors; Standardization for female medical officer, RHS -A doctors , nurses, LHV's, FWW,CMW's	District wide	Jhpiego global package available; needs to be reviewed adapted and endorsed in Pakistan; needs to be translated in local language	Provincial or District FPTU/CoEs
2 weeks training on Minilap (includes BCS + counselling)	Female doctors from the DOH	District wide	Package available; needs to be reviewed and endorsed.	RHS-A master training centers
1 week training on NSV (includes BCS + counselling)	Male Medical Officer	District wide	Locally available at PWD	PWD master training centers
2 days training on HTSP and Family Planning	Train LHW's from selected facilities	Province wide	Available; needs adaptation for LHW's; needs Urdu translation	District FPTU or LHW training centers
4 days Training of MSU staff on MSU guidelines	Train Government's nominated staff of MSU from 4 districts	District based	Jhpiego developed MSU guidelines	District FPTU/CoE

20

SUPPORTIVE SUPERVISION AND MONITORING

Introduction

Supervision, monitoring, and evaluation (M&E) are the built-in and ongoing Mechanisms of the departments of Health and Population Welfare in each of the provinces for ensuring and optimizing quality of care (QoC) for family planning/reproductive health (FP/RH) Services. This manual sets the minimum standards for all contraceptive methods as M&E guidelines and for vigilance on the part of the Programme staff for ensuring that these standards are achieved and maintained. Regular supervision, coupled with M&E, leads to early and rapid identification of problems so they can be promptly rectified through remedial actions or necessary changes, thereby ensuring that the services remain safe, effective, with minimal complication rates and high quality, and prescribed standards maintained.

Supportive Supervision

Supportive Supervision is a process of guiding, helping, training and encouraging staff to improve their performance in order to provide high-grade family planning facilities.

A supervisor is responsible for the performance of clinical staff (like medical officers, nurses, Midwives, Female welfare workers, Female Welfare Assistants) and non-clinical staff (like receptionists, cleaners). A skilled supportive supervisor builds and works with a team to improve performance. Supervision can be conducted by someone at the clinic or externally by someone who makes periodic supervision visits. The on-site supervisor helps staff improve and maintain performance and quality of services as part of everyday activities. Many of these supervisors also provide clinical services at the facility. Other health care delivery sites may be visited only from time to time by an external supervisors and therefore do not have the benefit of a supervisor's skills on a routine day-to-day basis.

A supervisor has many responsibilities. Supervisors are responsible for ensuring that sufficient numbers of trained staff exist to provide high quality FP services, that those staff

have the supplies and equipment they need to use their skills, and that there are financial resources to buy necessary supplies. They are responsible for scheduling, maintaining with the district and provincial level of their departments , problem solving, creating an environment of team work, motivating staff, facilitating community outreach and so on.

Responsibilities of a Supportive Supervisor

There are certain essential responsibilities that a supervisor must accept to improve staff performance and the quality of the FP services. A supportive supervisor:

- Helps build close links with the community
- Identifies, with stakeholders, standards of good performance and clearly and effectively communicates them to staff members
- Works with staff to periodically assess their performance in comparison to these standards
- Provides feedback to staff about their performances
- Decides at which level of the FP service delivery it is appropriate to address a performance gap
- Works with staff and the community to identify appropriate changes that will lead to the improvement of performance by staff and improvement in quality FP services delivered
- Mobilizes resources from different sources to implement changes
- Monitors the effects of selected interventions

In carrying out the above responsibilities, the supervisor needs certain skills which include bring able to :

- Involve Stakeholders
- Use clinical standards and guidelines to assess technical abilities (Example Clinical competence, counseling, infection prevention skills)
- Use standards to assess competence in management areas such as logistics, financial management and strategic planning
- Facilitate team work
- Motivate staff to perform well
- Persuade those with resources of the facility needs
- Facilitate meetings and discussions
- Provide constructive, timely and interactive feedback
- Communicate clearly and effectively with staff and decision makers
- Gather and analyze information
- Lead the design and implementations of interventions
- Make decisions
- Delegate duties to staff members

Some of the personal attributes of the supportive supervisor should develop include:

- Leadership and ability to motivate others
- A desire to help others to do the best they can do

- A commitment to the provision of high quality FP services
- Strong communication skills
- Openness to new and creative ideas

Who can do Supportive Supervision?

To ensure quality of Family Planning services, a provincial Quality Improvement Committee (comprising of representatives from provincial Health and Population Technical Teams) is responsible to oversee the implementation of the overall QI approach at family planning facilities. A Quality Improvement Team at the district level composed mainly of technical staff who will help implement a standardized QI approach across Health and Population Facilities. The members of the QIT includes EDO(H), District Population Welfare Officer (DPWO), Technical DPWO, Tehsil Population Welfare Officer, DHO, Asst. Health Inspectors, In-charge of DHDCs, ADCO, Community Midwifery Tutors, Gynecologists, In-charges of RHS-A/FHCs and District IRMNCH Coordinators.

Process of Supportive Supervision

The process that supervisors use to identify a performance gap and its causes and to create solutions for closing the gap is called performance improvement and is illustrated in the figure 20-1

This process involves a series of steps that are repeated until the desired performance is achieved. These steps can be used to identify solutions for any type of performance gap. These gaps may be found in practices to prevent infection, management of stocks, counseling, crowding of wards and lateness of employees.

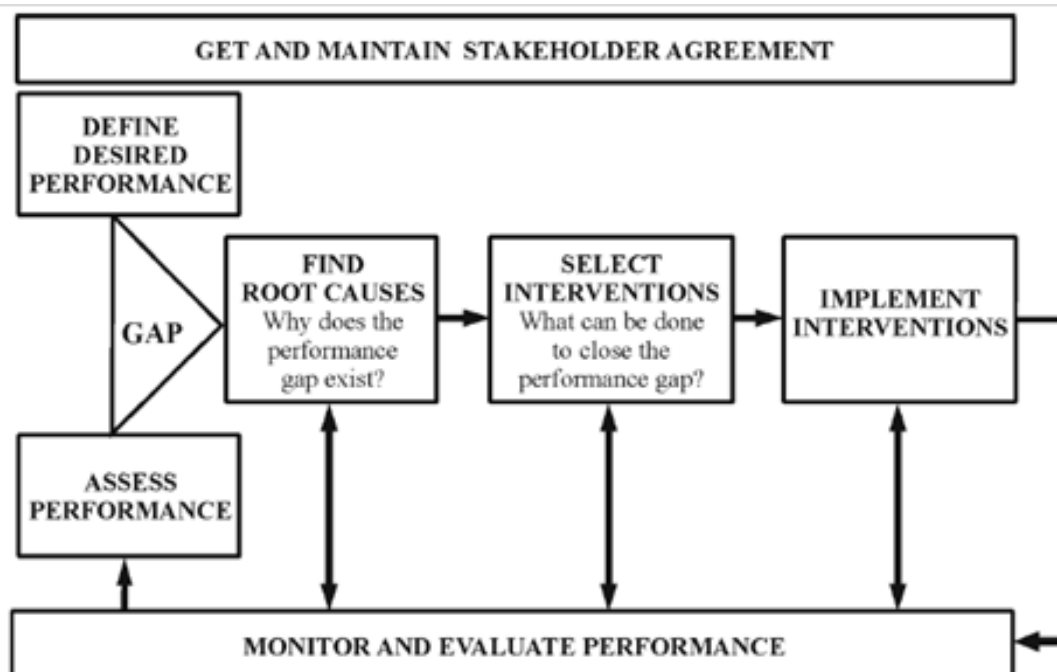

The performance improvement has following steps:

- **Get and maintain stakeholder's involvement:** For the performance improvement process to be implemented, buy-in-from all stakeholders is necessary. Stakeholders are the people who have an interest in improving staff performance and the quality of services the FP service delivery site. Stakeholders may include staff, community members and representatives of different levels of FP service delivery system.
- **Define desired performance:** For staff members to perform well, they must know what they are supposed to do. Family Planning Performance standards are available. Staff must know not only what their job duties are, but also how to perform them. Desired performance should be realistic and take into account the resources at the facility. Desired performance should be based on common goals of stakeholders, including the expectations of the community.
- **Assess Performance:** The supervisors should continually assess how the staff and the facility are performing compared to how they are expected to perform. This assessment can be done on an ongoing, informal basis or more formally on periodic basis. Methods to assess performance include conducting self-assessments and obtaining feedback from clients or observations by staff.
- **Find causes of performance gaps:** A performance gap exists if the supervisor and staff find that what they are actually doing does not meet the set standards of performance. If a gap is found, then the supervisor needs to carefully explore with staff why the gap is there. What is preventing the desired performance? Sometimes the reasons for poor performance are not immediately clear. It may take some time to find the real cause.
- **Select and Implement steps to improve performance:** Once the causes of the performance gap have been identified, the supervisor and the staff will need to develop and implement action plan to improve the performance. Steps may be planned to improve the knowledge and skills of staff. There may be ways to improve the environment or support systems that make it possible for the staff to perform well. There are many different ways to improve workers performance. It is important to select methods that match facility resources.
- **Monitor and Evaluate Performance:** Once interventions have implemented, it is very important to determine whether performance has improved. Is the staff now closer to meeting the established standards? If not, the staff team will need to go back and consider again, what is preventing the desired performance. It is important that the interventions be targeted at the real cause of the gap. If performance has improved, it is important for the supervisor to continue monitoring to make sure that the desired level of performance is maintained.

Table 20-2. Examples of Using Records and Reports to Assess Facility Performance and Quality of Services

WHERE DO YOU LOOK?	WHAT DO YOU FIND?	WHAT MIGHT IT TELL YOU?	HOW MIGHT YOU USE THIS INFORMATION?
Family Planning Attendance Register, Quarterly Reports Stock Cards	Contraceptive Method Mix	Whether a variety of contraceptive is being used Which contraceptive is being used the most	<ul style="list-style-type: none"> ■ To ensure that the inventory of contraceptives is sufficient ■ To assess changes in usage and demand for different contraceptives ■ To make sure counseling is adequate ■ To assess the need for staff training ■ To analyze the effectiveness of community outreach/ education efforts

Planning a Supportive Supervision Visit

A supervision visit must be well planned. If it is not, time will be wasted and the visit will accomplish little. To ensure a well-planned supervision visit, work with the facilities you supervise to:

- Set the objectives for your supervision visit:

It is important to set objectives for your visit so that both you and those at the facility know what to expect and how to prepare. A general objective for your visit might be:

To improve the performance of FP clinic X with regard to management of supplies, medicines and consumables

Specific Objectives might include:

- Orientation of the staff on infection prevention practices
- Review Inventory records and ordering procedures with the staff

Decide which activities you will undertake while at FP Clinic/Facility

You need to think through exactly what you will do while at the facility and inform the staff

there of these proposed activities. Again, this will help you and the staff make the most of your time. Examples of specific activities you might undertake include:

- Hold an informational and planning meeting with the staff
- Observe a specific clinical procedure
- Observe infection prevention practices
- Examine supplies and equipment
- Observe counseling and client-provider interaction
- Hold discussions with clients
- Examine client records
- Examine inventory records
- Help staff to conduct self-evaluations
- Examine statistical information
- Hold a meeting to address specific problems

Review the performance and quality standards and indicators that have been established.

It is important to know what you are looking for when you visit the facility. What are the standards given in the checklist that have been set and what will you do to determine if improvements have been made. Review any previous supervision reports to identify problems that were to be addressed and the actions that were to be undertaken since the last visit.

Review the supervision instruments that you will use to assess the quality and performance.

A review of the performance standards and areas that needed improvement as of the previous visit will guide you in selecting the supervision instruments (e.g., observation checklists) that you will need for this visit. Make sure you are familiar and comfortable with the use of these instruments.

Make administrative preparations.

Be sure that you have made all the administrative arrangements to ensure a smooth and productive trip. For example, you will need to:

Gather any documents necessary for the visit, including supervision instruments, new guidelines or directives from the departments of health and Population Welfare, and permission forms for observing clinical procedures.

Notify the facility about the details of your visit including the date, the amount of time you will need, the people you wish to see, and the activities you plan to conduct.

Make logistical arrangements including transport, fuel and travel documents.

Conducting a Supportive Supervision Visit

During the visit, the supervisor demonstrates technical as well as communication and management skills. The Supervisor also transfers knowledge and skills, and facilitates problem solving by the team. The supervisor uses an inclusive style of communication and makes use of supervision instruments to document what is observed during the visit.

- Hold a meeting with the facility's supervisor and staff:

This meeting can be brief and should not disrupt daily activities. The purpose of this meeting is to share the objectives of the visit and to plan how the visit will take place. At a small facility, all staff should participate. At a larger facility, the facility's supervisor, unit in-charge and unit staff should participate.

During this meeting, the supervisor should review with the staff the problems and strengths identified during the last visit and ask about progress made toward resolving problems previously identified and any new problem recently surfaced.

At the end of this initial meeting, all staff should be aware of the objectives of the supervision visit, and should understand how the visit will take place. It should be clear to the supervisor and all staff which areas of the facility will be the focus of the visit.

- Observe service provision and client-provider interaction.

At the core of Family Planning services supervision is observation of service provision. The critical areas to observe include:

1. Welcome and communication with clients
2. Technical competence of providers
3. Infection prevention practices

Examine client records and clinic statistics.

It is important to periodically examine client records and FP clinic statistics to make sure that they are well kept and up-to-date.

Clinic statistics represent a numeric picture of clinic activities. They can illustrate changes in monthly or yearly service delivery trends, which may provide one measure of how services are improving. These statistics should be reviewed with the staff, and the supervisor should make sure the staff understand why they are collecting these statistics and what they mean.

Observe work conditions.

Staff performance at a Family Planning facility is often closely related to the working conditions there. Usually, the better the conditions, the better the performance and results.

Discuss services with clients and other users.

An important aspect of performance and quality improvement is the viewpoint of those who use the services provided. The supportive supervisor should always reserve time to find out what clients think about the FP services provided. Their feedback can be recorded as a part of this exercise.

Meet again with staff to summarize the visit.

After observing, discussing and meeting with staff and clients, the supportive supervisor should meet again with staff in order to:

- Acknowledge progress made since the last visit
- Identify priorities and discuss any issues that need immediate attention
- Discuss available resources for problem solving
- Establish a plan for addressing priority issues
- Discuss follow-up activities the supervisor will need to undertake

Establish a follow-up action plan

Finally, the supportive supervisor should meet with the internal supervisor to establish a follow-up action plan, complete with names of persons responsible for specific activities and dates by which those activities are to take place. It is this action plan that the external supervisor can refer to when meeting with the staff at beginning of the next supervisory visit.

The progress of supportive supervisory exercise should be shared at District Technical Committee Meeting on Monthly/Quarterly basis. The district reports should be submitted to Provincial Quality Improvement Committee.

Monitoring is the periodic collection and analysis of selected indicators to enable managers/supervisors to determine whether key activities are being carried out as planned and have the expected effects on the target population. Monitoring, therefore, is a process to assess implementation against the work plan, which outlines the project activities to achieve specific objectives, and thus provides feedback to managers so they can improve operational plans and take corrective actions.

In an organization, two types of monitoring activities can be carried out- "routine" and "short-term". Routine monitoring (for example, Population Welfare MIS) involves compiling information on a regular, ongoing basis for a core set of indicators providing sufficient information to track progress; this kind of monitoring can be used to identify where programme implementation is not proceeding as planned. Short-term monitoring is undertaken for a limited period of time and usually for a specific activity, especially when some new activities/projects or processes are implemented. Once implementation is under way, key indicators are incorporated into routine monitoring.

In an M&E system, indicators are used to measure achievement of targets; assess

changes/trends in health status; compare the level of achievement between working areas or project sites; and identify currently underserved areas. Indicators are used to assess, analyze, and manage FP/RH services. An M&E system answers the questions of relevance (does the project address specific needs), efficiency (are resources being used wisely), effectiveness (are the desired results achieved), and impact (to what extent have project activities brought about changes for the betterment of individuals and/or the community).

Table 20-2. Supportive Supervision Checklist

A- Family Planning Facility Audit

1. Facility Information

District: _____

Tehsil: _____

Date and Time: _____

Facility Name: _____

Supportive Supervisor/s: _____

Address: _____

Telephone No: _____

Status: Open Closed

2. Management Issues

a) General Displays (in place):

Direction Board		Sign Board		FP Performance Chart		Area Profile	
<input type="checkbox"/> YES	<input type="checkbox"/> NO	<input type="checkbox"/> YES	<input type="checkbox"/> NO	<input type="checkbox"/> YES	<input type="checkbox"/> NO	<input type="checkbox"/> YES	<input type="checkbox"/> NO

b) Building:

Condition			Surrounding Condition		Ventilation		Water Available	
<input type="checkbox"/> GOOD	<input type="checkbox"/> SATISFACTORY	<input type="checkbox"/> POOR	<input type="checkbox"/> HYGIENIC	<input type="checkbox"/> UNHYGIENIC	<input type="checkbox"/> YES	<input type="checkbox"/> NO	<input type="checkbox"/> YES	<input type="checkbox"/> NO

Electricity		Easy to Access		Condition of Procedure Areas		Storage Facilities	
<input type="checkbox"/> YES	<input type="checkbox"/> NO	<input type="checkbox"/> YES	<input type="checkbox"/> NO	<input type="checkbox"/> Satisfactory	<input type="checkbox"/> Unsatisfactory	<input type="checkbox"/> YES	<input type="checkbox"/> NO

3. Capacity Building of Service Providers (Last training received by):

S.No	Designation	Training Discipline	Date/Duration

c) Transport:

Available		Total No. of Vehicles		If Off Road	
<input type="checkbox"/> YES	<input type="checkbox"/> NO	<input type="checkbox"/> OFF ROAD	<input type="checkbox"/> ON ROAD	<input type="checkbox"/> REPAIRABLE	<input type="checkbox"/> NON-REPAIRABLE

d) Record and Registers Up-to-Date/Signed:

Stock Register		Cash Book		Log Book		Vehicle History	
<input type="checkbox"/> YES	<input type="checkbox"/> NO	<input type="checkbox"/> YES	<input type="checkbox"/> NO	<input type="checkbox"/> YES	<input type="checkbox"/> NO	<input type="checkbox"/> YES	<input type="checkbox"/> NO

e) Financial Performance:

Budget Allocated	Budget Released	Budget Utilized	%age utilization on Release

f) Contraceptive Replenishment/Storage Condition, etc.:

Are the contraceptives received regularly		Date last received	Storage condition		All contraceptives available in sufficient quantity	
<input type="checkbox"/> YES	<input type="checkbox"/> NO		<input type="checkbox"/> POOR	<input type="checkbox"/> SATISFACTORY	<input type="checkbox"/> YES	<input type="checkbox"/> NO

g) Medicines Availability/Storage Condition, etc.:

Are the medicines received regularly		Date last received	Storage condition		All medicines available as per standard list	
<input type="checkbox"/> YES	<input type="checkbox"/> NO		<input type="checkbox"/> POOR	<input type="checkbox"/> SATISFACTORY	<input type="checkbox"/> YES	<input type="checkbox"/> NO

h) Equipment/Furniture:

Office Equipment Condition			All medicines available as per standard list		
<input type="checkbox"/> GOOD	<input type="checkbox"/> SATISFACTORY	<input type="checkbox"/> POOR	<input type="checkbox"/> GOOD	<input type="checkbox"/> SATISFACTORY	<input type="checkbox"/> POOR

4. Programme Interventions:

a) Contraceptive Performance during the Last 3 Months:

Month	Condom	Oral Pills			IUCD		Injection		Vasectomy	BTL
		COCs	POPs	EC	CU T 380 A	CU T 375 A	DMPA	NET- EN		
Total										
Average										

b) Contraceptive Stock Position:

Month		Condom	Oral Pills			IUCD		Injection	
			COCs	POPs	EC	CU T 380 A	CU T 375 A	DMPA	NET-EN
1	Stock Available as Per CLR-6								
2	Stock Physically available								
3	Stock sufficient for no. of Months								
4	Stock Expired								
5	Stock Near Expiry								
Total									
Average									

4. Information, Education, and Communication Advocacy

a) IEC Material:

Available	Yes	No
Displayed	Yes	No

B- Technical Audit**A- FAMILY PLANNING SERVICES AT FACILITY**

STANDARDS	VERIFICATION CRITERIA	Y/N/N/A	COMMENTS
<ul style="list-style-type: none"> An adequate FP counseling area exists 	Observe: <ol style="list-style-type: none"> If the counseling area provides privacy Counseling kit and job aids are available 		
<ul style="list-style-type: none"> Statistical data is recorded and shared with district office 	Verify the availability of <ol style="list-style-type: none"> Registers to record FP services Monthly reports on FP 		
<ul style="list-style-type: none"> Smooth supply chain management of FP commodities in place 	Verify with facility in-charge <ol style="list-style-type: none"> If he/she is following procedure for timely requisition An appropriate storage system is present 		
<ul style="list-style-type: none"> Equipment is clean and functional 	Observe whether the facility has following items: <ol style="list-style-type: none"> Clean Examination Table Clean sink with soap and water Light source Clean FP kits 		

B- COUNSELING SERVICES

STANDARDS	VERIFICATION CRITERIA	Y/N/N/A	COMMENTS
<ul style="list-style-type: none"> The provider establishes a cordial relationship with the client 	Observe whether the provider: <ol style="list-style-type: none"> Greets the client Ask the client her reproductive goals and needs for contraception 		
<ul style="list-style-type: none"> The provider uses effective communication skills 	Observe whether the provider: <ol style="list-style-type: none"> Addresses client's questions and concerns Uses language that client understands Uses A/V Aids Tells the client about all the FP methods available Rules out the pregnancy 		

C-BARRIER METHOD

STANDARDS	VERIFICATION CRITERIA	Y/N/N/A	COMMENTS
<ul style="list-style-type: none"> Provider gives information about advantages 	Observe that provider tells the following major advantages: <ol style="list-style-type: none"> It protects against STIs Is safe and has no hormonal side effects. 		
<ul style="list-style-type: none"> Provider gives information about limitations 	Observe that provider informs the following limitations to the client <ol style="list-style-type: none"> Condoms can weaken if stored too long or in too much heat or sunlight, or if used with oil-based lubricants, and then may break during use. Some people may be allergic to the lubricant on some brands of condoms. 		
<ul style="list-style-type: none"> Provider instructs the client about its correct use 	Observe that the provider delivers the following information <ol style="list-style-type: none"> Check manufacturing or expiry date on package Do not use teeth or sharp objects to open condom package. Place condom on the tip of the erect penis and squeeze air out of tip of condom about 1 – 2 cm. Unroll condom down the penis. Take off the condom carefully, without spilling semen. 		
<ul style="list-style-type: none"> Provides information about EC in case of slippage or condom rupture 	Observe that provider guides the client about Emergency Contraception <ol style="list-style-type: none"> Client can immediately visit nearest facility for EC EC can be taken within 120 hours 		

D- COMBINED ORAL CONTRACEPTIVE PILLS (COCs)

STANDARDS	VERIFICATION CRITERIA	Y/N/N/A	COMMENTS
PRE-REQUISITES			
<ul style="list-style-type: none"> The provider screens the client for eligibility to use COCs 	Observe whether the provider excludes: <ol style="list-style-type: none"> Exclusive Breastfeeding (baby less than 6 months old) < 21 days in non-breastfeeding women Blood clots in legs, lungs or eyes High Blood Pressure (= or >140/90 mmHg) 		
<ul style="list-style-type: none"> The provider provides specific information about COCs 	Observe that the providers explains: <ol style="list-style-type: none"> One active pill taken a daily preferably with meals Common side effects can be nausea, dizziness or breast tenderness 		
METHOD PROVISION			
The provider gives the pill pack with specific information	Provider explains the management of missed pills <ol style="list-style-type: none"> If you miss one or two pills, take the pill as soon as remembered If you miss three or more pills in the 1st or 2nd week, advise her to continue using pills. Avoid sex for 1 week or use condom. In case of unprotected sex within the last 5 days, use EC pills If you miss three or more pills in the 3rd week, continue using the pills. Discard iron pills and start the new pack. Avoid sex for 1 week or use condom. In case of unprotected sex within the last 5 days, use EC pills 		

POST INSTRUCTIONS			
The provider explains the warning signs	Observe the provider explains that in case of following warning signs, the client should report to facility <ol style="list-style-type: none"> a. Severe leg pain b. Severe Chest pain c. Severe Headache 		
SIDE EFFECTS & THEIR MANAGEMENT			
<ul style="list-style-type: none"> • Nausea and Vomiting 	<ol style="list-style-type: none"> a. Client should take the pill with meals and not on an empty stomach. b. Check for pregnancy; if no cause is found, reassure the client c. If she vomits within 2 hours of taking the pill, ask her to take an extra pill from another packet. 		
<ul style="list-style-type: none"> • Breast Tenderness 	<ul style="list-style-type: none"> • Examine breasts for lump • If none, reassure the client. • Prescribe a mild analgesic (paracetamol), if necessary. 		
<ul style="list-style-type: none"> • Weight Gain 	<ul style="list-style-type: none"> • If the increase is up to 2kg in months then asks her if appetite has increased, asks her to reduce food intake, especially fats and sweets. • If the increase is more than 2 kg in 3 months. Stop pills; provide another suitable contraceptive method. 		

E- PROGESTIN ONLY PILLS CONTRACEPTIVES (POCs)

STANDARDS	VERIFICATION CRITERIA	Y/N/N/A	COMMENTS
PRE-REQUISITES			
<ul style="list-style-type: none"> Provider explains the advantages of POP 	<p>Observe that provider explains following advantages:</p> <ul style="list-style-type: none"> Monthly periods are regular; lighter monthly bleeding and fewer days of bleeding; milder and fewer menstrual cramps. Can be used by nursing mothers starting 6 weeks after childbirth. Do not affect quantity and quality of breast milk. 		
<ul style="list-style-type: none"> Provider explains the limitation of the method 	<p>Observe that provider explains following limitations:</p> <ul style="list-style-type: none"> For breastfeeding women, longer delay in return of monthly bleeding after childbirth (lengthened postpartum amenorrhoea) Breast tenderness Headaches 		
<ul style="list-style-type: none"> Provider explains timings to use 	<p>Providers explains the timings as per history of the client:</p> <ul style="list-style-type: none"> POPs may be taken by breastfeeding women as early as 6 weeks after childbirth and at any time after confirmation that she is not pregnant. If menstrual periods have returned, she can start POPs at any time it is reasonably certain that she is not pregnant. POPs may be taken by non-breastfeeding women, within 3 weeks of childbirth. 		

METHOD PROVISION			
	<p>Provider gives the POP pack with following instructions:</p> <ul style="list-style-type: none"> The client should always take one pill each day at approximately the same time for maximum efficacy, until the pill packet is finished. When she finishes one pack, she should take the first pill from the next pack on the very next day. It is very important to start the next pack on time. Starting a pack late risks pregnancy. 		
POST INSTRUCTIONS			
Management of Missed Pills	<p>If a woman is 3 or more hours late in taking a pill or misses one completely then for breastfeeding women whether missing a pill places her at risk of pregnancy depends on whether or not her monthly bleeding has returned. Therefore, ask her to</p> <ul style="list-style-type: none"> Take a missed pill as soon as possible. Keep taking pills as usual, one each day <p>If the client has regular monthly bleeding:</p> <ul style="list-style-type: none"> Use a backup method for the next 2 days. Also, if she had sex in the past 5 days, she can consider taking ECPs. 		
MANAGEMENT OF SIDE EFFECTS			
<ul style="list-style-type: none"> Breast Tenderness 	<ul style="list-style-type: none"> Advise her to wear a supportive bra (including during strenuous activity and sleep). Use hot or cold compresses. Give her: Tab. ibuprofen (200–400 mg), 1BD OR Tab. paracetamol (325–1,000 mg), 1TDS 		

<ul style="list-style-type: none"> Headache 	<ul style="list-style-type: none"> Give her: Tab. ibuprofen (200–400 mg), 1BD OR Tab. paracetamol (325–1,000 mg), 1TDS If the Headaches that get worse or occur more often than counsel her for another suitable contraceptive method. 		
<ul style="list-style-type: none"> Amenorrhoea 	<ul style="list-style-type: none"> For breast feeding mother, reassure her that this is normal during breastfeeding. It is not harmful. For women who are not breastfeeding, Reassure her that it is not harmful; in fact, lack of menstruation will help improve her anemia. 		

F- PROGESTIN ONLY INJECTABLE CONTRACEPTIVES (PICs)

STANDARDS	VERIFICATION CRITERIA	Y/N/N/A	COMMENTS
PRE-REQUISITES			
<ul style="list-style-type: none"> The Provider screens the client for eligibility to use PICs 	Observe whether the provider excludes the following conditions: <ol style="list-style-type: none"> Known or suspected Breast cancer Active Liver Disease (hepatitis or tumor) High Blood Pressure(= or> 140/90 mmHg) Migraine 		
<ul style="list-style-type: none"> The provider gives specific information about PICs 	Observe that provider briefly explains the following important points: <ol style="list-style-type: none"> Common side effects can be changes in menstrual bleeding, weight gain, nausea, breast tenderness, headaches and delay in fertility 		

METHOD PROVISION			
	<p>a) First injection to be given between first and seventh day of the menstrual period or if starting after day 7 use a back-up method or abstain from sexual intercourse for one week.</p> <p>b) Explains the client to return to the clinic every 2 months for NET-EN and 3 months for DMPA.</p> <p>c) If client is late for the next injection, for more than 2 weeks tells the client to start a back - up method/abstain from sex and report to the clinic</p>		
POST INSTRUCTIONS			
The provider explains the warning signs	<p>Observe the provider explains that in case of following warning signs, the client should report to facility</p> <p>a) Very painful headache</p> <p>b) Heavy bleeding</p> <p>c) Depression</p> <p>d) Severe lower abdominal pain</p> <p>e) Pus, bleeding or prolonged pain at injection site</p>		
SIDE EFFECTS AND THEIR MANAGEMENT			
<ul style="list-style-type: none"> Changes in menstrual bleeding 	<p>Explains the client that menstrual bleeding pattern changes usually begins after 2-3 months and users have no bleeding by the end of the first year. Reassure her that amenorrhea is not harmful; in fact, lack of menstruation will help improve her anemia.</p>		

• Weight gain	Advises her to modify her eating habits especially decreasing the intake of fats and sweets intake.		
• Nausea	Checks for pregnancy; if no cause is found, reassures the client		
• Breast tenderness	Examines breasts for lump. If none, reassures the client. Prescribe a mild analgesic (paracetamol), if necessary.		
• Headaches	Headaches that get worse or occur more often than counsels her for another suitable contraceptive method.		
• Delay in fertility	Reassures the woman		

F - INTRAUTERINE CONTRACEPTIVE DEVICE (IUCD)

STANDARDS	VERIFICATION CRITERIA	Y/N/N/A	COMMENTS
PRE-REQUISITES			
• The provider screens the client for eligibility to use IUCD	Observe whether the provider excludes: <ol style="list-style-type: none"> Acute purulent vaginal discharge (treat first) Vaginal bleeding Severe menstrual cramping 		
• The provider gives specific information about IUCD	Observe that provider explains that: <ol style="list-style-type: none"> CU 380 A effective for 12 years and Multi Load 375 for 5 years. Insertion is done usually during menstruation, but can be inserted anytime if the woman is sure that she is not pregnant Removal can be done at any time on clients request 		
METHOD PROVISION			
• The provider performs pre-insertion tasks	Provider performs hand hygiene, explains woman about the procedure, gently performs bimanual examination and immerses gloves in 0.5% chlorine solution		

<ul style="list-style-type: none"> The provider performs insertion using sterile technique 	<ul style="list-style-type: none"> Provider puts on sterile gloves. Explains and gently inserts the speculum Explains and then applies antiseptic solution twice to the cervix Gently grasps the vulsellum at 10 to 2 O' clock position Sounds uterus using non touch technique Sets guage to measure uterine depth Removes loaded inserter tube without touching anything that is not sterile Inserts the CU T 380 A using the withdraw technique Assure IUCD is in position by repositioning Cuts IUCD strings to 3-4 cms in length Removes inserter tube, explains and gently removes the vulsellum and speculum 		
<ul style="list-style-type: none"> The provider performs post insertion tasks 	<p>Provider place the instruments in 0.5% chlorine solution for 10 minutes Remove the gloves after being immersed in 0.5% chlorine solution. Performs hand hygiene. Records in client card and register</p>		
POST INSTRUCTIONS			
<ul style="list-style-type: none"> The provider gives instructions about the return and follow up visits. Explains the warning signs 	<p>Discusses return/follow up visit</p> <p>Observe the provider explains that in case of following warning signs, the client should report to facility</p> <ul style="list-style-type: none"> Pregnancy Abdominal pain Infection Not feeling well 		

	<ul style="list-style-type: none"> Missing strings/the plastic tip of the IUCD can be felt 		
SIDE EFFECTS AND THEIR MANAGEMENT			
Vaginal discharge	Treats her with an antibiotic and asks her to return if not settled		

G - POSTPARTUM INTRAUTERINE CONTRACEPTIVE DEVICE

STANDARDS	VERIFICATION CRITERIA	Y/N/N/A	COMMENTS
PRE-REQUISITES			
<ul style="list-style-type: none"> The provider counsels and screens the woman in early labor or postpartum period (within 48hours) of delivery. 	Observe whether the provider gives: <ol style="list-style-type: none"> Method specific information about immediate postpartum IUCD Makes a note in her record and notify care providers about her decision to have immediate postpartum IUCD 		
<ul style="list-style-type: none"> The provider ensures that the IUCD is an appropriate method for the woman in early labor or within 48hrs of delivery Reviews the woman using Pre- insertion screening 	Provider performs brief assessment of the woman and rules out the following conditions: <ol style="list-style-type: none"> More than 18hrs from rupture of membrane to delivery of baby Unresolved postpartum hemorrhage Sign/symptoms of chorioamnionitis fever, foul smelling vaginal discharge, severe abdominal pain Extensive genital trauma 		
METHOD PROVISION			
<ul style="list-style-type: none"> The provider completes all pre-insertion tasks for post-placental or intra- cesarean IUCD insertion 	<u>For Post-placental IUCD insertion,</u> observe the provider: <ol style="list-style-type: none"> Puts on HLD or sterile gloves. Inspects the perineum, labia and vagina walls for lacerations. Gently visualizes the 		

	<p>cervix by depressing the posterior wall of the vagina and cleans cervix and vagina with antiseptic solution 2 times.</p> <ul style="list-style-type: none"> c. Gently grasps the anterior lip of the cervix. d. Grasps IUCD in its sterile package with Kelly's forceps using no-touch technique. e. Exerts gentle traction on the anterior lip of the cervix. f. Inserts Kelly's forceps with IUCD into lower uterine cavity. Avoids touching the walls of the vagina with the IUCD g. Stabilizes uterus by elevating the uterus with palm of hand against uterine body h. Gently moves the IUCD upward toward fundus, following contour of uterine cavity. i. Keeps the forceps closed so IUCD does not become displaced. j. Confirms that end of Kelly's forceps has reached the fundus. k. Opens the forceps and releases IUCD at fundus by sweeping the Kelly's forceps to side wall of uterus slightly tilting it inwards. l. If IUCD is seen protruding from cervix, removes and reinserts. m. Removes all used instruments and immerses them in 0.5% chlorine solution. 		
--	---	--	--

OR			
<p>The provider correctly inserts IUCD during caesarean section (with Sponge Holding forceps/ manually)</p>	<p><u>Inserting IUCD during Cesarean Section</u></p> <p>Observe the provider:</p> <ol style="list-style-type: none"> a. Ensures that the woman has received uterotonic drugs as part of a routine cesarean delivery after the baby is out. b. Inspects the uterine cavity for malformation which limits the woman’s successful use of the IUCD c. Stabilizes the uterus by grasping it at the fundus. d. Inserts the IUCD (manually or by Sponge Holding forceps) through the uterine incision to the fundus of the uterus e. Places the IUCD strings in lower uterine segment near the internal cervical os. f. Takes care not to include IUCD strings in repair of uterine incision. 		
<p>The provider correctly carried out post procedure infection prevention tasks and instrument processing.</p>	<ol style="list-style-type: none"> a. Immerses gloves & speculum/ metal instruments in 0.5% chlorine solution for 10 minutes for decontamination. b. Performs hand hygiene after removing gloves. 		

POST INSTRUCTIONS			
The provider provides post insertion instructions to the woman. Explains the warning signs	<ul style="list-style-type: none"> a. Reviews IUCD side effects and normal postpartum symptoms with the woman. b. Tells the woman when to return at 6 weeks for IUCD/PNC/newborn checkup. c. Emphasizes that she should come back at any time she has a concern or experiences warning signs 		
SIDE EFFECTS AND THEIR MANAGEMENT			
Vaginal discharge	Treats her with an antibiotic and asks her to return if not settled		

H - IMPLANTS

STANDARDS	VERIFICATION CRITERIA	Y/N/N/A	COMMENTS
PRE-REQUISITES			
Provider gives specific information on Implant to the woman	Asks the woman what she already knows about Implant and corrects any misinformation. Tells about effectiveness, common side effects and warning signs		
METHOD PROVISION			
The service provider inserts Implant properly	<ul style="list-style-type: none"> a. Washes hands thoroughly and puts on sterile gloves. b. Prepares instruments and other necessary supplies on HLD/sterile tray c. Uses proper infection prevention procedures d. Applies antiseptic solution to the insertion area two times e. Gives an injection of local anesthesia under the skin (sub-dermal) of the arm. f. Inserts the implants through trocar just under the skin g. Closes the incision after implants are inserted with an adhesive bandage. 		
POST INSTRUCTIONS			
The woman receives Post insertion counseling	Observe if the provider: (expulsion of rods)		
SIDE EFFECTS AND THEIR MANAGEMENT			
Pain/swelling at the injection site	Treats her with an antibiotic and asks her to return if not settled		

I. MINILAPORATOMY UNDER LOCAL ANESTHESIA

STANDARDS	VERIFICATION CRITERIA	Y/N/N/A	COMMENTS
PRE-REQUISITES			
Provider gives specific counselling & information on minilaparotomy to the woman	<ul style="list-style-type: none"> a. Asks the woman what she already knows about minilap and corrects any misinformation. b. Tells about permanent method, effectiveness, common side effects and warning signs. c. Confirms she is not pregnant. 		
The provider gets written informed consent from the client	<ul style="list-style-type: none"> a. Explains that there are temporary methods of contraception available to the client and her husband b. Explains that the effect of the procedure is permanent. c. Takes written sign on informed consent form of the client 		
The provider assesses clients eligibility for Minilap and prepares necessary equipments and supplies	<ul style="list-style-type: none"> a. Observe that the provider takes medical history b. Observe the provider performs general physical examination c. The provider advises for following lab investigations d. Observe functional operating room e. Observe the provider gives pre medication to the clients prior to the surgery 		
METHOD PROVISION			
The service provider performs tubal ligation (ML) procedure	<ul style="list-style-type: none"> a. Positions the client to the operation bed comfortably b. Uses proper infection prevention practices c. Inserts uterine elevator into the uterus through the vagina and cervix to raise each of the 2 fallopian tubes Gives injection of local anesthesia in above the pubic hair line. d. Make small transverse incision 2-5 cm in anesthetized area e. Ligates the tubes in proper way. f. closes the incision with stitches and covers it with and adhesive bandage. 		

POST INSTRUCTIONS			
The woman receives Post procedural care& counseling	<ul style="list-style-type: none"> a. Observe the providers takes vital signs and check bleeding from incision. b. Ask client to take rest. 		
SIDE EFFECTS AND THEIR MANAGEMENT			
Pain/swelling at the incision site	Treats her with an antibiotic and asks her to return if not settled		

J. NO- SCALAPEL VASECTOMY

STANDARDS	VERIFICATION CRITERIA	Y/N/N/A	COMMENTS
PRE-REQUISITES			
Provider gives specific counselling & information on NSV to the man	<ul style="list-style-type: none"> a. Asks the man what he already knows about NSV and corrects any misinformation. b. Give the client information about the contraceptive choices available and the risks and benefits for each. c. Explain the difference between reversible and permanent contraception. Correct false rumors or misinformation about all methods. 		
The provider gets written informed consent from the client	<ul style="list-style-type: none"> a. Explains that there are temporary methods of contraception available to the client and his wife. b. Explains that the effect of the procedure is permanent. c. Explain that NSV does not protect against GTIs and other STIs d. Takes written sign on informed consent form of the client 		
The provider assesses clients eligibility for Minilap and prepares necessary equipment and supplies	<ul style="list-style-type: none"> a. Observe that the provider takes medical history b. Observe the provider performs general physical & and scrotal examination. c. The provider advises for following lab investigations d. Observe functional operating room e. Observe the provider gives pre medication to the clients prior to the surgery 		

METHOD PROVISION			
The service provider performs tubal ligation (ML) procedure	<ul style="list-style-type: none"> a. Positions the client to the operation bed comfortably b. Prepares the procedure site. c. Uses proper infection prevention practices d. Identify, isolate and fix the right & left vas deferens under the median raphe at the junction of the middle and upper one third of the scrotum. e. Gives injection of local anesthesia at proper site. f. Puncture scrotal skin and anterior wall of vas using medial blade (left blade for right-handed person) of dissecting forceps g. Isolate the vas from other structures using dissecting forceps. h. After careful separation of fascia and blood vessels ligate the prostatic end of the vas at both sides. i. Check scrotum and ensure that both vas deferens are ligated and in proper position. j. Pinch puncture site tightly for a minute k. Apply antiseptic solution to the wound and use sterile gauze dressing with tape. Put on scrotal support, if possible. 		
POST INSTRUCTIONS			
The man receives Post procedural care& counseling	<ul style="list-style-type: none"> a. Observe the providers takes vital signs and check bleeding from incision. b. Ask client to take rest. c. Provide client with necessary condoms for 3 months. d. Advise client to return for semen analysis after 3 months. 		
SIDE EFFECTS AND THEIR MANAGEMENT			
Pain/swelling at the incision site	Treats him with an antibiotic and asks him to return if not settled		

Table 20.4: CLIENT EXIT INTERVIEW

QUESTIONS FOR A FAMILY PLANNING SERVICES EXIT INTERVIEW

Instructions: Explain that the clinic is interested in ensuring the quality of reproductive Health-care services and the client will be asked a few questions about the services s/he received.

Reassure the client that the details of this discussion and the responses will not be linked with her/his name. Ensure that the client is comfortably seated. Read each question carefully and record the client's answers.

1. How long did you wait between the time you first arrived at this clinic and the time you saw a healthcare provider?
2. How do you feel about the length of this waiting time?
3. During this visit, did the provider give you any material to take home to read?
4. Were you assured of confidentiality and privacy?
5. Did you attend group health talks at the clinic today?
6. What topics were covered in the talk?
7. Was there information given in the talk that you did not understand? If yes, what?
8. What is the main reason you chose to come to this clinic instead of another one?
9. Overall, how would you rate the services you received at this clinic today?
10. Can you give one major suggestion that you think will improve the services at this clinic?
11. The next time you need family planning services, where will you go for these services.
12. If your sister wants to start using family planning services, where would you suggest she go for these services?
13. Were you satisfied with the information or service that you received?
14. Do you have any further concerns or questions that you want to address?

Table 20.5: FAMILY PLANNING SERVICES

SEVERE ADVERSE EVENT REPORT FORM

Date of Event:

Date of Report Completion:

Date of Submission:

Patient Name:

Patient Record No:

1. Describe the Serious Adverse Event (SAE):
 General Condition:
 B.P:
 Pulse:
 Respiratory rate:
2. Gender of client who experienced SAE: Male _____ Female _____
3. Name of client and contact information:
 Name:
 Address:
 Phone/Mobil:
4. Date of birth (day/month/year) _____/_____/_____
5. Emergency contact:
 Name:
 Address:
 Phone/Mobile
 Relationship to client:
6. Name and location of facility where SAE occurred:
7. Name and address of individual involved in patient care when the SAE occurred:

 Provider 1 Name:
 Address:

 Provider 2 Name:
 Address:
8. Individual and institutional name and addresses of individuals managing the clinical care of the patient with SAE:
 Facility:
 Clinician(s):
9. What Family Planning method she was already using?

10. Describe the FP method that lead to Complication or SAE.
11. Describe the clinical management of the severe adverse event (medical and or surgical interventions, length of hospitalization, medications prescribed, etc.):
12. Current status/condition of the client (please state whether management/ treatment is complete in addition to clinical outcome of the patient OR if the patient is still being managed for sequelae of the SAE):
13. Is the client referred to high level center for care?
14. Was the potential for the severe adverse event discussed with patient before the medical/ surgical service?
 Yes
 No
If no, please explain: _____

15. Is the signed consent form attached?
 Yes
 No
If no, please explain: _____

16. List the medications the client was taking prior to onset of the SAE
17. List all medications administered for management of the SAE
18. Please indicate below what official of the Department / clinical site has been notified of the severe adverse event. (Provide name of person, title, contact address, phone, address, and date of notification.)

Person:
Title
Contact Address
Phone
Date of notification

Name(s) and Signature(s) of Staff Person Filing This Report

Contact information of person completing this form:

Name:

Address:

Phone:

For use by the Incharge of the Facility

I have reviewed the report of the incident and confirm the completeness and accuracy of the patient record for reporting of a severe adverse event. Theynteam and I agree to respond to any question that might arise regarding this patient/client.

PRINTED NAME

SIGNATURE

DATE

20.6: PERFORMA FOR DEATH INVESTIGATION

Name: _____ Age: _____

Address: _____

Date of arriving at the facility: _____

Pre-Operative Risk Factors (if any): _____

Date and Time of Operation: _____

Type of Anaesthesia: _____

Operation Procedure: _____

Name of Surgeon: _____ Name of Assistant: _____

Complications (if any):

During Surgery: _____

Treatment Given: _____

During Recovery: _____

Treatment Given: _____

If death occurred at home (after discharge):

(See Client Record)

Probable cause of death: _____

REFERENCES

Abeykoon ATPL. 1999. Monitoring progress and ensuring accountability of reproductive health service provision: A road map. *Innovations* 7–8: 213–228. International Council on Management of Population Programme, Kuala Lumpur.

Bertrand JT et al. 1995. Access, quality of care, and medical barriers in family planning programs. *International Family Planning Perspectives* 21(2): 64–69, 74.

Bluestone J, Chase R, and Lu ER. 2006. *IUD Guidelines for Family Planning Service Programs*. Jhpiego: Baltimore, Maryland.

Bongiovanni A et al. 2005. Promoting the Lactational Amenorrhea Method (LAM) in Jordan Increases Modern Contraception Use in the Extended Postpartum Period. The LINKAGES Project, Academy for Educational Development: Washington, D.C.

Borda M. 2009. *Family Planning Needs during the Extended Postpartum Period in Pakistan*. ACCESS-FP Program: Baltimore, Maryland.

Cleland J and Ali MM. 2004. Reproductive consequences of contraceptive failure in 19 developing countries. *Obstetrics and Gynecology* 104(2): 314–320.

Dunson DB, Colombo R, and Baird DD. 2002. Changes with age in the level and duration of fertility in the menstrual cycle. *Human Reproduction* 17: 1399.

Gallen M, Lettenmaier C, and Green CP. 1987. Counseling makes a difference. *Population Reports Series J*(35): 1–31.

Georgetown University, Institute for Reproductive Health, and Jhpiego. 2009. *Lactational Amenorrhea Method (LAM): A Learning Resource Package for Family Planning Service Providers and Trainers*. Georgetown University: Washington, D.C.

Goldman DA. 1991. The role of barrier precautions in infection control. *Journal of Hospital Infection* 18(Suppl. A): 515–523.

Government of Pakistan, Ministry of Population Welfare (MoPW). 2009. *ISO certification records/reports*. (1 February). MoPW: Islamabad.

Government of Pakistan, Ministry of Population Welfare (MoPW). 2008. *PC-I. Population Welfare Program 2003–2008. Federal Activity Modified in the light of CDWP and Post-CDWP Decisions*. MoPW: Islamabad.

Government of Pakistan, Ministry of Population Welfare (MoPW). 2007. *Manual of Contraceptive Logistics*. (October). MoPW: Islamabad

- Government of Pakistan, Ministry of Population Welfare (MoPW). 2005. Islamabad Declaration [on Population and Development]. International Ulama Conference on Population and Development, MoPW: Islamabad.
- Government of Pakistan, Ministry of Population Welfare (MoPW). 2005. Manual on Monitoring and Supervision. (July) Population Welfare Programme, MoPW: Islamabad.
- Government of Pakistan, Ministry of Population Welfare (MoPW). 2002. Population Policy of Pakistan. (July). MoPW: Islamabad. At: <http://www.mowp.gov.pk/event3.html>
- Hare L et al. 2004. Reproductive health commodity security framework (graphic), in Rao R. 2008. Commodity Security for Essential Medicines: Challenges and Opportunities. USAID Deliver Project, Task Order 1: Arlington, Virginia.
- Hare L et al. (eds) and Bornbusch A (ed.). 2004. SPARHCS: Strategic Pathway to Reproductive Health Commodity Security. A Tool for Assessment, Planning, and Implementation. INFO Project/Center for Communication Programs, Johns Hopkins Bloomberg School of Public Health: Baltimore, Maryland.
- Hatcher R et al. 1997. The Essentials of Contraceptive Technology. Johns Hopkins University School of Public Health, Population Information Program: Baltimore, Maryland.
- Hight-Laukaran V et al. 2007. Multicenter study of the Lactational Amenorrhea Method (LAM): II. Acceptability, utility, and policy implications. *Contraception* 55(6): 337–346.
- Jhpiego. Reproductive Health Online (ReproLine). At: <http://www.reproline.jhu.edu/index.htm>
- Lobo RA Infertility. In: Katz VL et al. 2007. *Comprehensive Gynecology*, 5th ed. Mosby Elsevier: Philadelphia, Pennsylvania.
- Miller K et al. 1998. Clinic-Based Family Planning and Reproductive Health Services in Africa: Findings from Situation Analysis Studies. Population Council: New York.
- National Institute of Population Studies (NIPS) [Pakistan], and Macro International Inc. 2008. Pakistan Demographic and Health Survey 2006–07. National Institute of Population Studies and Macro International Inc.: Islamabad.
- Pandit T, Bornbusch A, et al. 2004. Contraceptive Security: Ready Lessons: Overview. U.S. Agency for International Development: Washington, D.C. At: http://www.usaid.gov/our_work/global_health/pop/techareas/contrasecurity/index.html.

Pathfinder International. 2002. Comprehensive Reproductive Health Training Curriculum. Pathfinder: Watertown, Massachusetts.

Perkins JJ. 1983. Principles and Methods of Sterilization in Health Sciences, 2nd ed. Charles C. Thomas Publisher Ltd.: Springfield, Illinois.

Population and Development Commission Hears Speakers Describe Efforts to Implement Cairo Programme of Action. 1999. (Country Report: ICPD+5). At: <http://www.un.org/News/Press/docs/1999/19990322.pop712.html>.

Population Council. 2005. A Client-Centered Approach to Reproductive Health: A Trainer's Manual. Population Council: Islamabad. At: http://www.popcouncil.org/pdfs/CCA_TrainersManual.pdf.

Saeed GA et al. 2008. Change in trend of contraceptive uptake: Effect of educational leaflets and counseling. *Contraception* 77(5): 350–354.

Sami N and Ali TS. 2006. The cultural politics of gender for infertile women in Karachi, Pakistan. Presentation at “Gender Studies Here and Now” conference, Pretoria, South Africa, 17 January.

Shelton J, Angle MA, and Jacobstein RA. 2001. Medical barriers to access to family planning. *Lancet* 340: 1334–1335.

South East Asia Regional Office (SEARO)/World Health Organization. 1988. A Manual on Infection Control in Health Facilities. SEARO: New Delhi.

Speizer IS et al. 2000. Do service providers in Tanzania unnecessarily restrict clients' access to contraceptive methods? *International Family Planning Perspectives* 26(1): 13–20, 42.

Stanback J and Twum-Baah KA. 2001. Why do family planning providers restrict access to services? An examination in Ghana. *International Family Planning Perspectives* 27: 37–41.

Stanback J et al. 1997. Menstruation requirements: A significant barrier to contraceptive access in developing countries. *Studies in Family Planning* 28(3): 245–250.

Tietjen L, Bossemeyer D, and McIntosh N. 2003. Infection Prevention Guidelines for Healthcare Facilities with Limited Resources. Jhpiego: Baltimore, Maryland.

Trussell J. Contraceptive efficacy. In: Hatcher R et al. (eds). 2007. *Contraceptive Technology*, 19th revised ed. Rates for monthly injectables and cervical cap are from Trussell J. 2004. Contraceptive failure in the United States. *Contraception* 70(2): 89–96.

United States Agency for International Development (USAID). 2004. Contraceptive security: What you can do. At: http://pdf.usaid.gov/pdf_docs/PNADC857.pdf.

World Health Organization (WHO). Medical Eligibility Criteria 2015.

World Health Organization (WHO). 2006. Report of a WHO Technical Consultation on Birth Spacing, Geneva, Switzerland, 13–15 June 2005. WHO: Geneva.

World Health Organization (WHO). 2005. Selected Practice Recommendations for Contraceptive Use, 2nd ed. WHO: Geneva.

World Health Organization (WHO). 2004. Guidelines for the storage of essential medicines and other health commodities. At: <http://apps.who.int/medicinedocs/es/d/Js4885e/8.3.html#Js4885e.8.3>.

World Health Organization (WHO). 2003. Guidelines for the Management of Sexually Transmitted Infections. WHO: Geneva.

World Health Organization (WHO). 1999. Safe Management of Wastes from Healthcare Activities. WHO: Geneva.

World Health Organization Department of Reproductive Health and Research (WHO/RHR) and Johns Hopkins Bloomberg School of Public Health/Center for Communication Programs (CCP), INFO Project. 2008. Appendix D. Medical Eligibility Criteria 2015. (Appendix from Family Planning: A Global Handbook for Providers.) At: <http://info.k4health.org/globalhandbook/remindersheets/Word-AppendixD.doc>.

World Health Organization Department of Reproductive Health and Research (WHO/RHR) and Johns Hopkins Bloomberg School of Public Health/Center for Communication Programs (CCP), INFO Project. 2007. Family Planning: A Global Handbook for Providers. CCP and WHO: Baltimore and Geneva.

Zieman M et al. 2007. Managing Contraception 2007–2009. Bridging the Gap Communications: Atlanta, Georgia..